

American Modeler — July 1960

SPECIFICATIONS
 AREA 785 SQUARE INCHES
 SPAN 61" LENGTH 48-5/8"
 WEIGHT 4-1/4 LBS.
 DESIGNED BY JERRY NELSON
 1959 AMA PYLON RACE WINNER

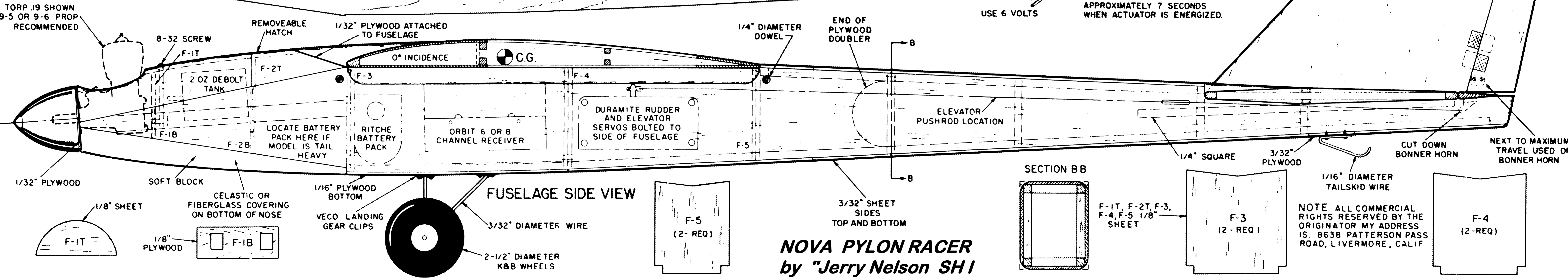

NOVA PYLON RACER by "Jerry Nelson SH1"

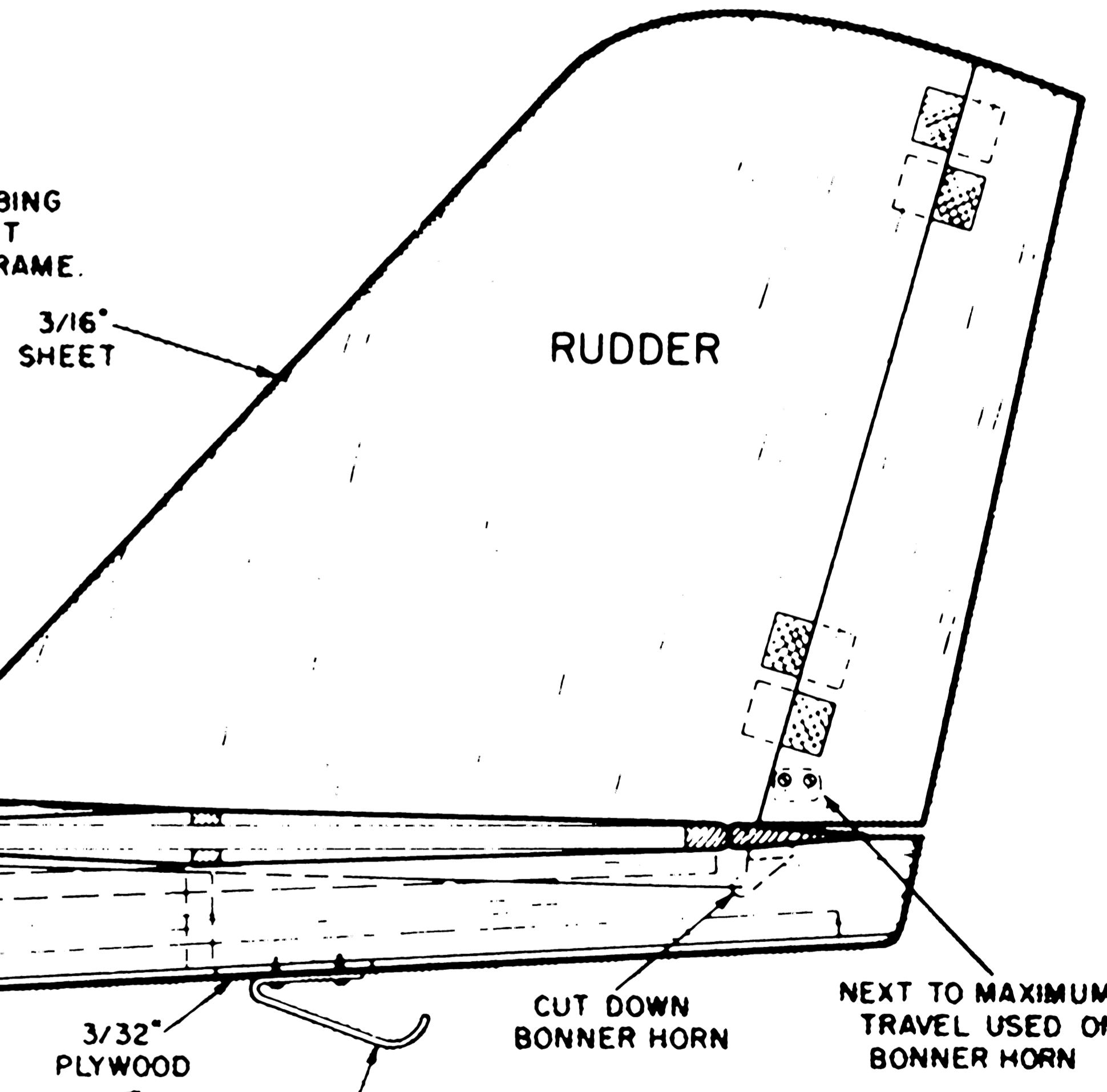
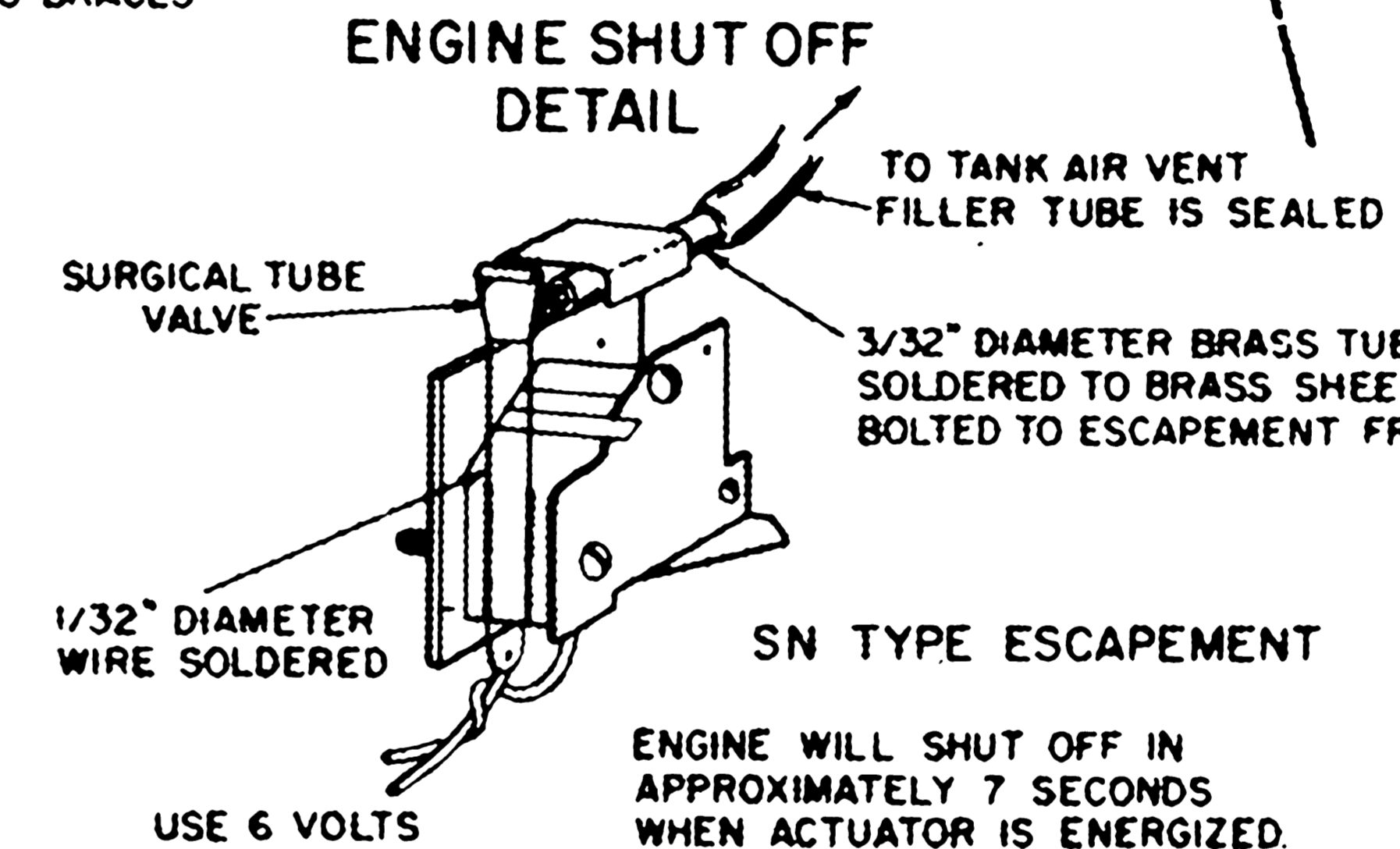
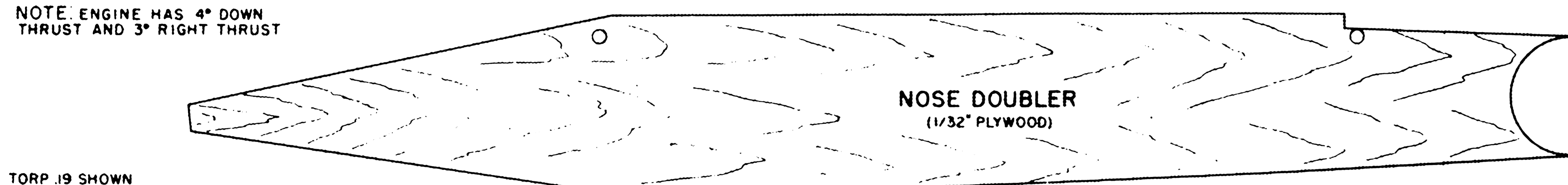
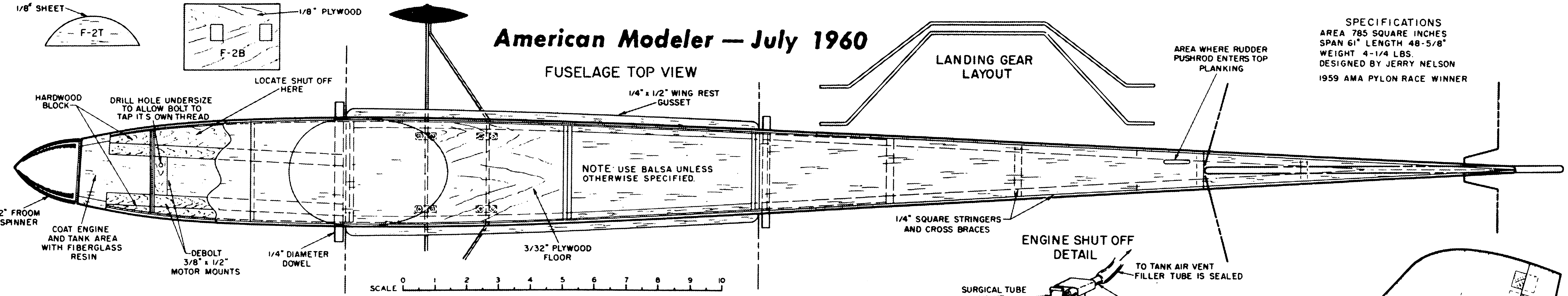
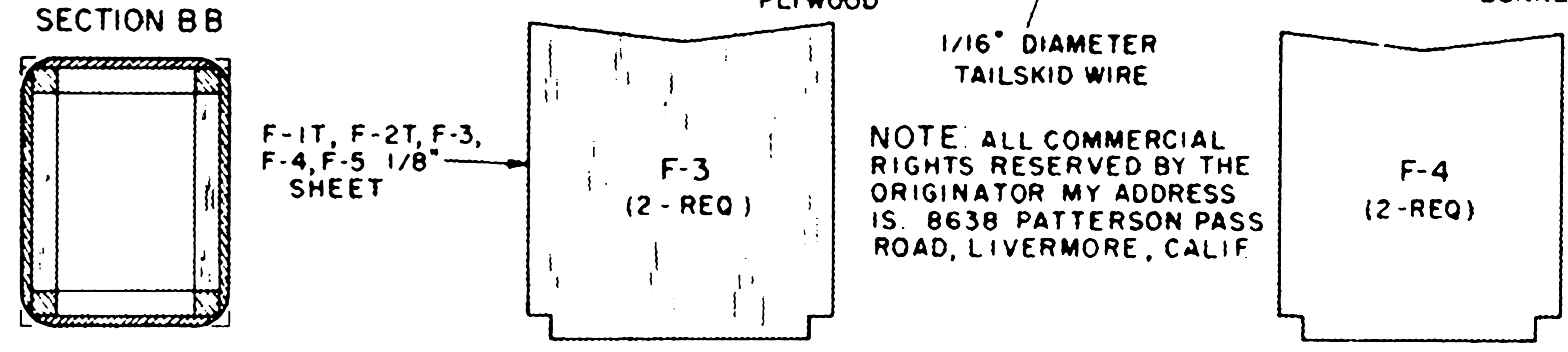

NOTE: ALL COMMERCIAL RIGHTS RESERVED BY THE ORIGINATOR MY ADDRESS IS: 8638 PATTERSON PASS ROAD, LIVERMORE, CALIF

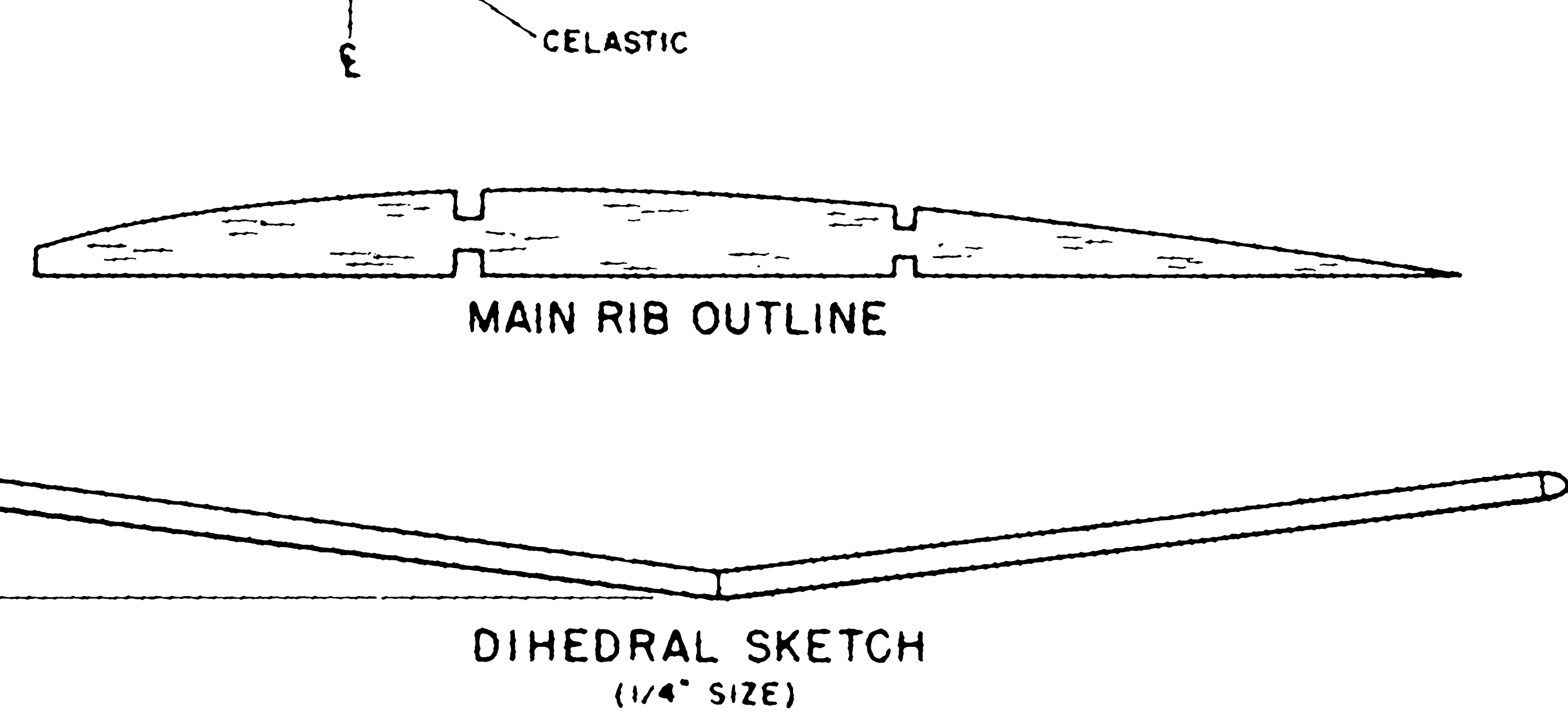
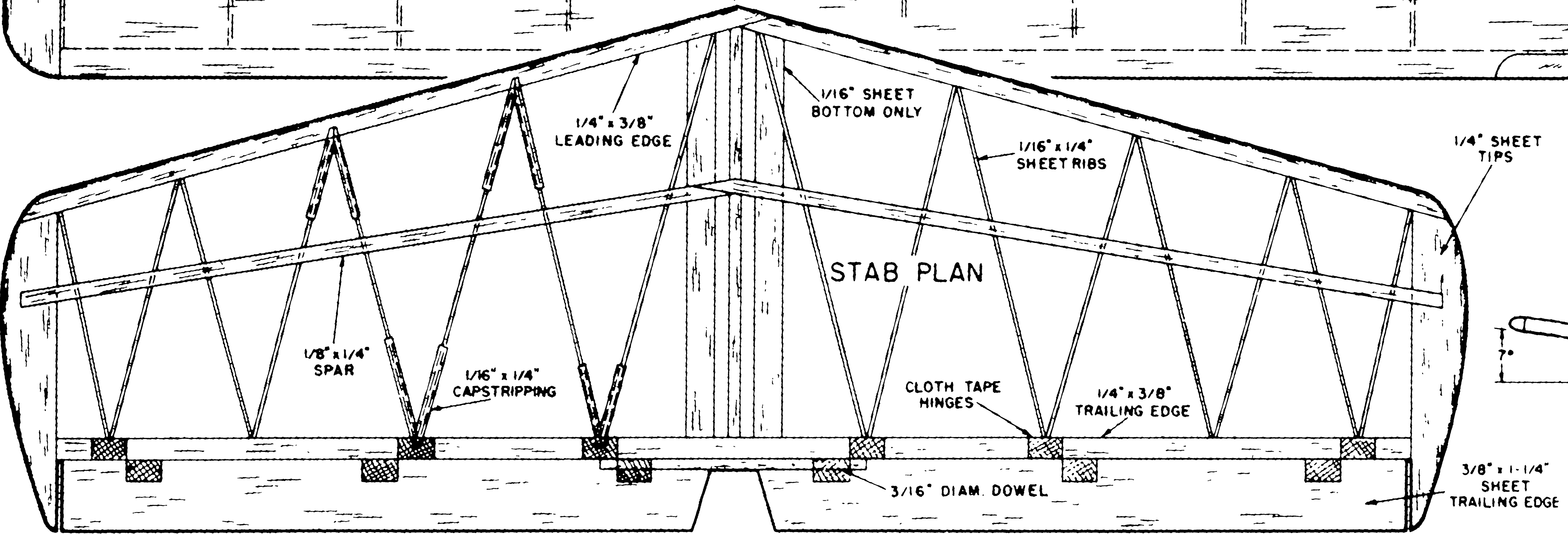


THE SERVO TRAVEL ON THE ELEVATOR IS CUT DOWN TO HALF THE ORIGINAL DISTANCE WITH THE REDUCED TRAVEL PYLON TURNS ARE DONE BY HITTING RUDDER TO BANK THE MODEL AND THEN HOLDING FULL UP WITHOUT THE REDUCED TRAVEL YOU HAVE TO BEEP UP. USE AN X-ACTO BLADE FOR CUTTING THE PRINTED CIRCUIT BOARD CUT ONLY A SMALL PORTION AT A TIME.

THE ELEVATOR HAS APPROXIMATELY 1/16" DROOP. LEAVE ELEVATOR IN NEUTRAL FOR FIRST FLIGHT THEN PUT IN 1/2 TURN OF DOWN AFTER FIRST FLIGHT. CONTINUE PROCESS UNTIL MODEL FLIES LEVEL.