

PLASTIKOVÁ VRTULE IGRA φ240 UPRAVENÁ
 .PODLE VÝKRESU (ROZVINUTÝ TVAR)

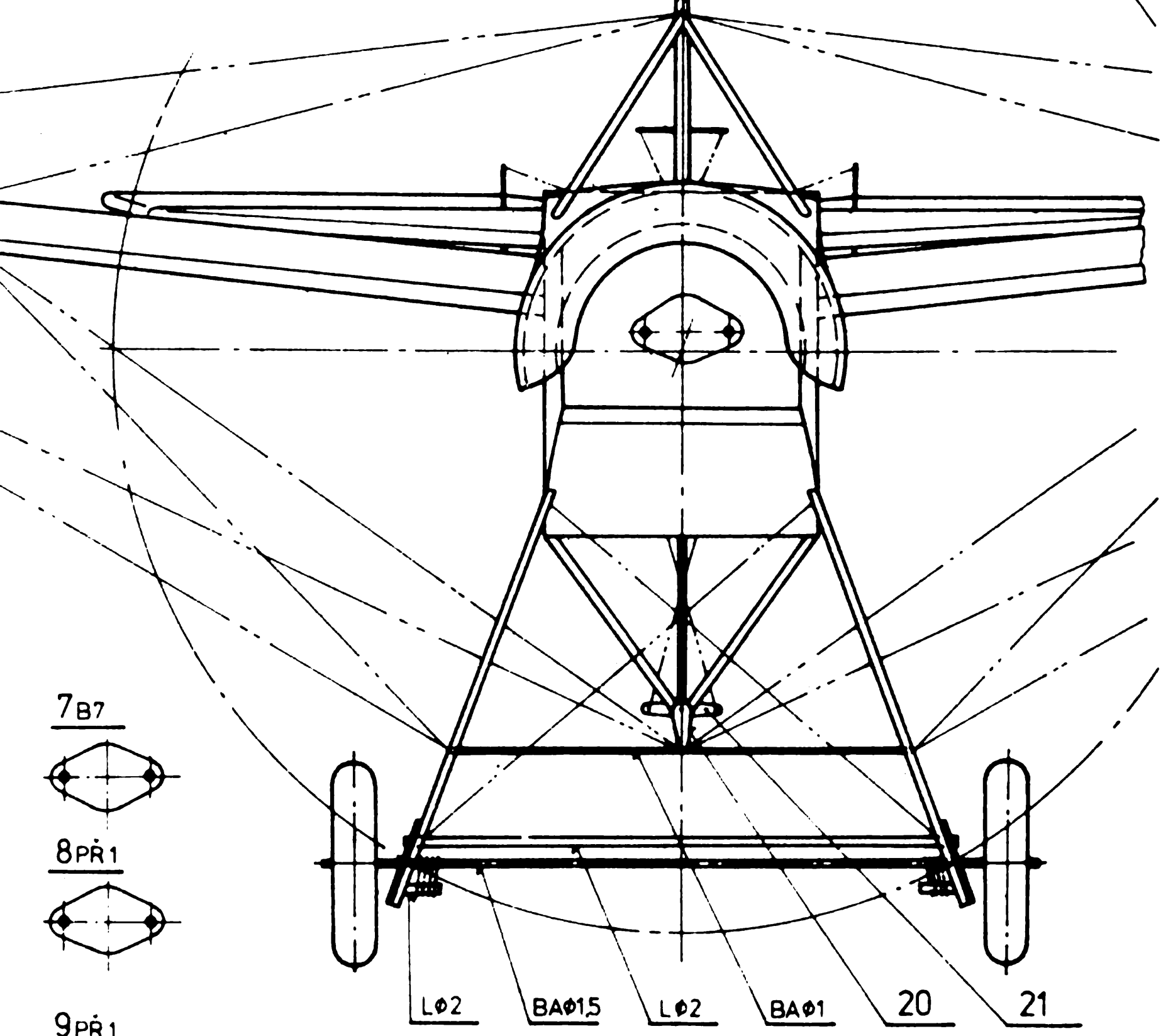
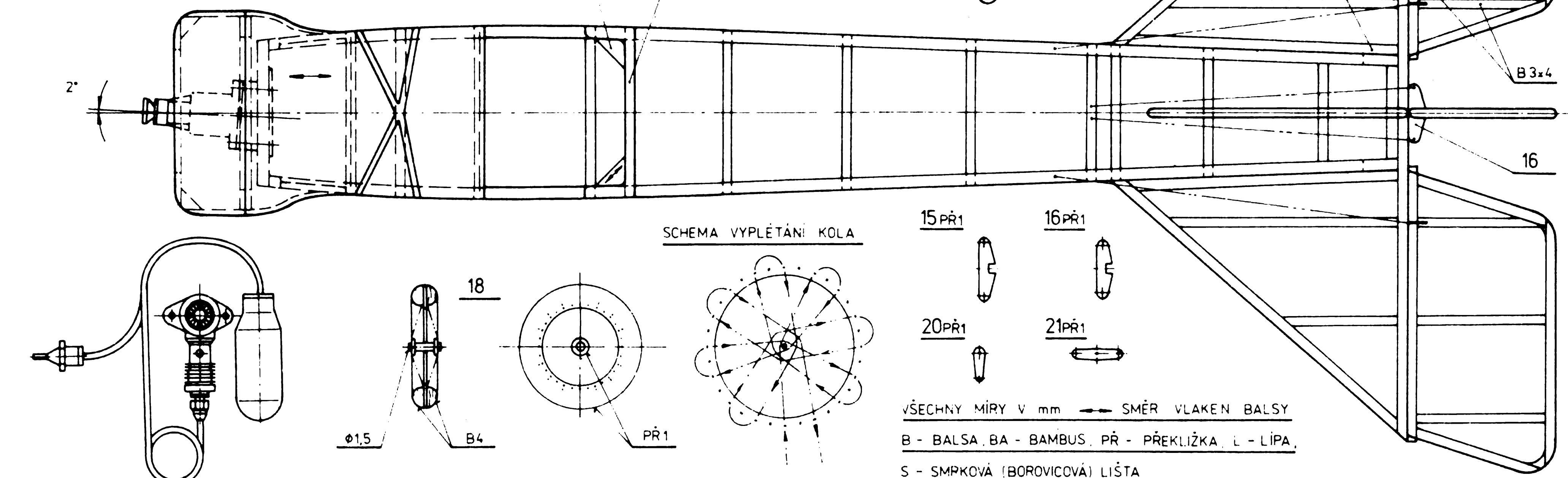

MAKETA HISTORICKÉHO LETADLA
ČIHÁK RAPID II
 ROZPĚTÍ 664 mm POHON MOTOR MODELA CO₂
 DÉLKA 510 mm HMOTNOST 80g
 KONSTRUKCE ING A ALFERY

VŠECHNY MÍRY V mm → SMĚR VLAKEN BALSY
 B - Balsa, BA - Bambus, PR - PŘEKLIŽKA, L - LÍPA,
 S - SMRČKOVÁ (BOROVICOVÁ) LIŠTA