

Fig. 5

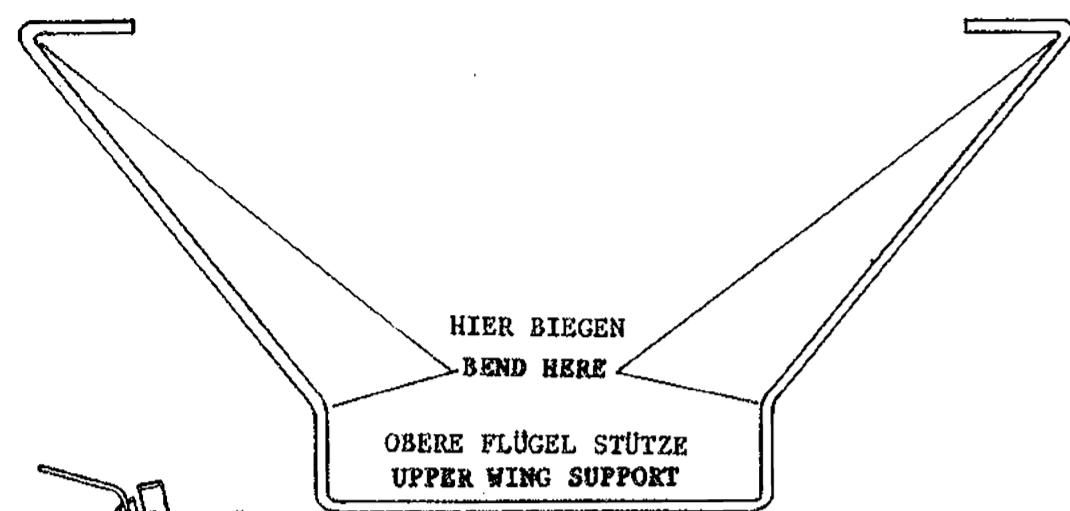

Fig. 4a

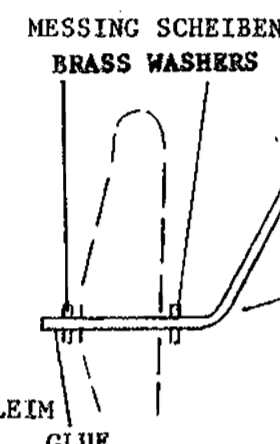

Fig. 4

- 4) TEIL F1 IN OBERE AUSSPARUNG VON SPANT A UND B SOWIE F2 IN AUSSPARUNG VON SPANT E, F UND G STECKEN UND VERLEIMEN DIE TEILE F6 AN BEIDEN SEITEN AN SPANT C UND D ANLEIMEN (FIG. 3)
- 2) TEIL F3 IN UNTERE AUSSPARUNG VON SPANT A, B UND C EINSETZEN SO WIE TEIL F4 AN SPANT D, E UND F (FIG. 1) GENAU AUSRICHTEN UND VERLEIMEN. ROHR MIT SPANTEN PUNKT VERLEIMEN (FIG. 2)
- 3) SPANT G AUF TEIL F4 STECKEN DIE TEILE F5 AN BEIDEN SEITEN DER SPANTEN R UND C ANLEIMEN (FIG. 3)

STEP 4
Glue F1 into top slots of A and B (Fig. 3). Glue F2 into top slots of E, F and G. Glue F6 pieces on both sides between formers C and D.

STEP 3
Slip former C onto F4. Position and spot glue in place (Fig. 3). Be sure C is in the proper position by gluing F5 to both sides of fuselage between F and G (Fig. 3).

STEP 2
When formers are dry, glue F5 into bottom slots of A, B and C and glue F4 into bottom slots of D, E and F (Fig. 1).

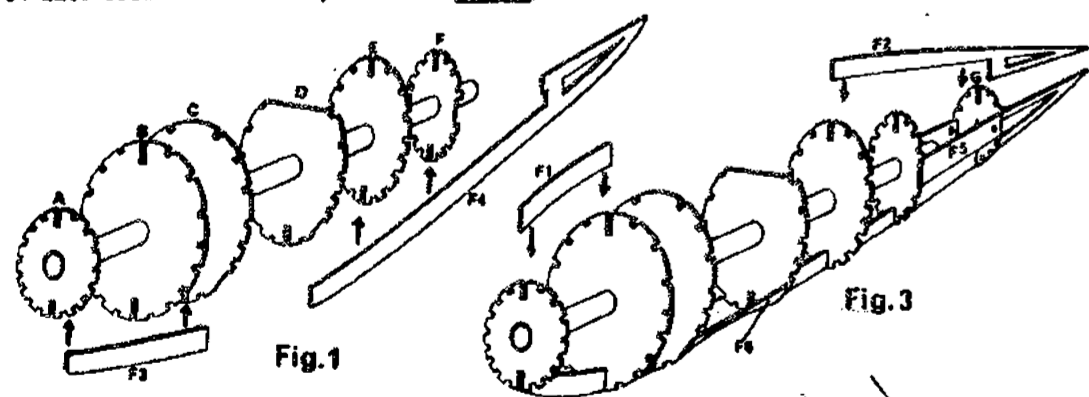

Fig. 1

Fig. 3

Fig. 2

- 1) ALLE SPANTEN VORSICHTIG AUS DRÜCKEN (SPANT A SPERRHOLZ) ROHR AUF PLAN (FIG. A) LEGEN UND SPANTEN MARKIEREN, SPANTEN A, B, C, D, E UND F AUF DAS ROHR SCHIEBEN (FIG. 1)

STEP 1
Carefully punch out all die-cut formers. Cut former A out of plywood (included) using pattern on plan as a guide. To achieve the correct alignment of formers, place the tube on plan (FIG. A), then mark positions with a pencil or pen. Slip formers A, B, C, D, E and F onto tube as shown in Fig. 1. Use your marks and side view of plan for exact positioning of pieces. Spot glue in place as in Fig. 2. CHECK ALIGNMENT.

NOTE: Diagram sketches may not be exact for the plan you are building, however, they show correct assembly procedures.

FUSELAGE CONSTRUCTION RUMPF

START HERE WITH COMET'S
SUPERX SPEED
CONSTRUCTION

After completing STEP 7, turn plan around and continue with WING CONSTRUCTION - STEP 8. (For ease in handling, plan can be cut in half on dotted line.)

STEP 7
Glue on all stringers as shown in Fig. 5 and Fig. A. Bend slightly to create curves.

STEP 6
Repeat this mounting procedure for upper wing support. Wing will be attached later.

STEP 5
Bend landing gear wire to angle as shown in Fig. A and Fig. 4. Lay wire over plan first to be sure you have the correct wire piece to be inserted. Now assemble the main landing gear wire (Fig. 4) to former B as indicated. Use "sandwich" technique gluing scrap hardwood around wire. This gives maximum support. Attach scrap wood braces to wire then wrap with paper as in Fig. 4a.

5) FAHRWERKDRAH'T SOWIE STÜTZE FÜR OBEREN FLÜGEL BIEGEN (FIG. 4)

6) FAHRWERKDRAH'T HINTER UND FLÜGEL STÜTZE VOR SPANT B EINLEIMEN WIE (FIG. 4) ZEIGT, EIN STÜCK ABFALL HOLZ AN DRAHT LEIMEN UND MIT PAPIER UNWICKELN (FIG. 4A)

7) RUMPFGRUPE EINLEIMEN LEICHT ZUR KURVE BIEGEN (FIG. 5 UND FIG. A) NACH DEM TROCKNEN ÜBER STEHENDE ENDEN ABSCHNEIDEN

After completing STEP 15, continue construction here.

STEP 16
IT IS IMPORTANT AT THIS TIME TO DECIDE WHAT VERSION OF THE PLANE YOU ARE BUILDING.

(A) RUBBER POWERED (Supplied)
If your plane is to be rubber powered, the plane should be covered with tissue (or other material) at this point. Refer to enclosed sheet for tips on covering your model. Insert propeller, button, hook and rubber band into fuselage tube. Fasten rubber band at rear with dowel thru F5 (Fig. 12).

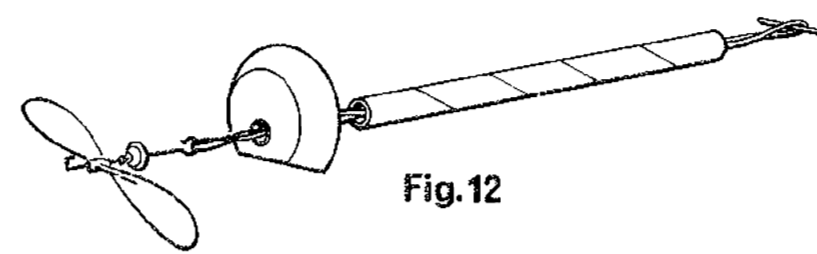

Fig. 12

16 A) GUMMIMOTOR PROPELLER UND LAGER AUF WELLE SCHIEBEN UND TALKEN BIRGEN, GUMMIBAND VON LÄNGE SCHNEIDEN UND VERKNOTEN EINHAKEN UND IN DEN RUMPF EINFÜHREN MIT WÜBEL (DURCH TEIL F5 STECKEN) FESTHALTEN (FIG. 12)

- A - COCKPIT-ENGINE COWLING
- B - SIDE PANEL
- C - UPPER WING RADIATOR
- D - RADIATOR CAP
- E - EXHAUST STACK
- F - COOLANT PORT
- G - MACHINE GUN
- H - TAIL SKID
- K - WING TIP
- L - PILOT

- A - MOTOR VERKLEIDUNG
- B - SEITEN TAFEL
- C - KÜHLER OBERER FLÜGEL
- D - KÜHLER KAPPE
- E - AUSSPUFF
- G - KÜHLERROHR
- H - M.G.
- J - SCHWANZSPORN
- K - RANDBOGEN
- L - PILOT

17 ZUSAMMENBAU DES MODELLS (FIG. 16)
UNTEREN FLÜGEL ZWISCHEN SPANT B UND C EINPASSEN (AUF GENAUEN SITZ ACHTEN) UND EINLEIMEN. ZUSÄTZLICHE UNTER DEN FLÜGEL LEIMEN UND BESPANNEN. OBERE FLÜGELSTÜTZE (DRAHT) IN SCHLITZE AN DER NASENLEISTE (UNTER) EINPASSEN UND EINLEIMEN DANN HARDHOLZPLÄTTCHEN DARÜBER LEIMEN (FIG. 17) FLÜGEL VERSTREBUNG AUS 1,5mm LEISTE SCHNEIDEN (BENUTZE FIG. A) ALS SCHABLONE) UND EINLEIMEN (SIEHE FIG. A) VERSTREBUNGEN ZWISCHEN DEN FLÜGELN EINLEIMEN UNTEREN FLÜGEL AN LW4 OBEREN/FLÜGEL AN UW6 SIEHE (FIG. B UND C) RADER AM FAHRWERKDRAH'T BEFESTIGEN (FIG. 4) RADFLÜGEL AUS ABFALL BALSZAUSSCHNEIDEN (FIG. C) ALS SCHABLONE NEHMEN) UND ZWISCHEN FAHRWERK LEIMEN (FIG. A, FIG. 16) HÖHEN UND SEITENRADER EINLEIMEN UND MIT DEN FLÜGELN AUSRICHTEN

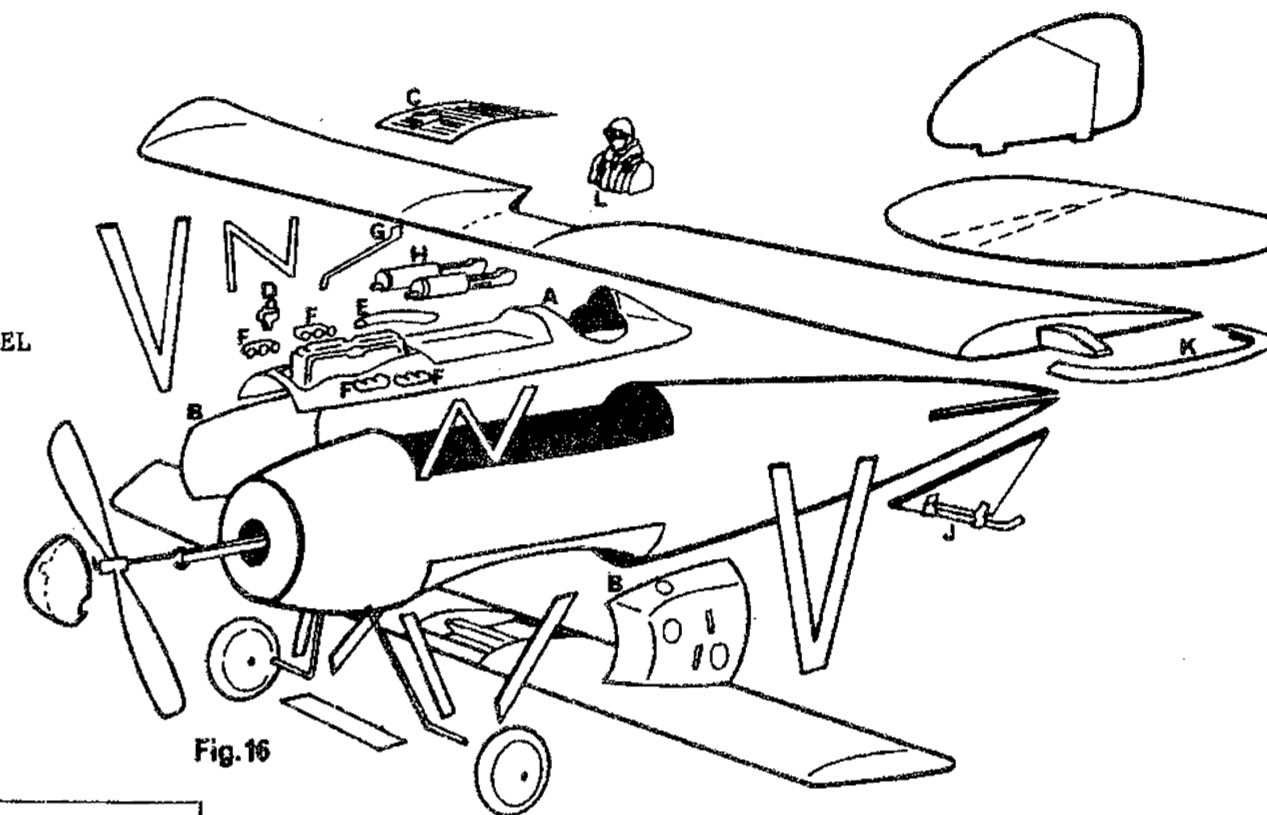
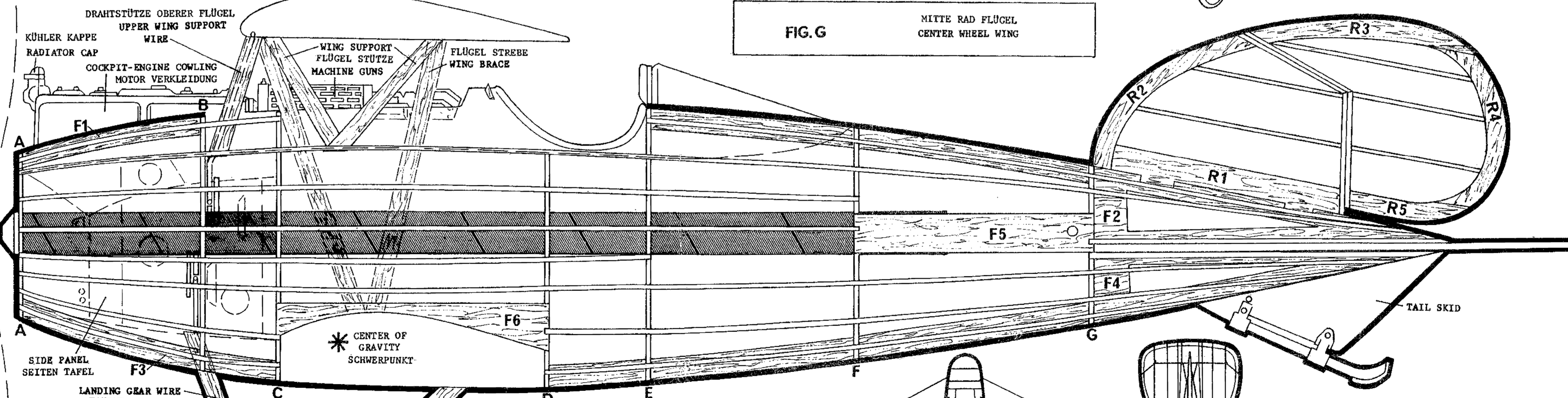

Fig. 16

FIG. G MITTE RAD FLÜGEL CENTER WHEEL WING



GEWICHT FÜR BALANCE ALS NOTIC ZUGEBEN
ADD WEIGHT (CLAY) FOR BALANCE AS NEEDED

FIG. A

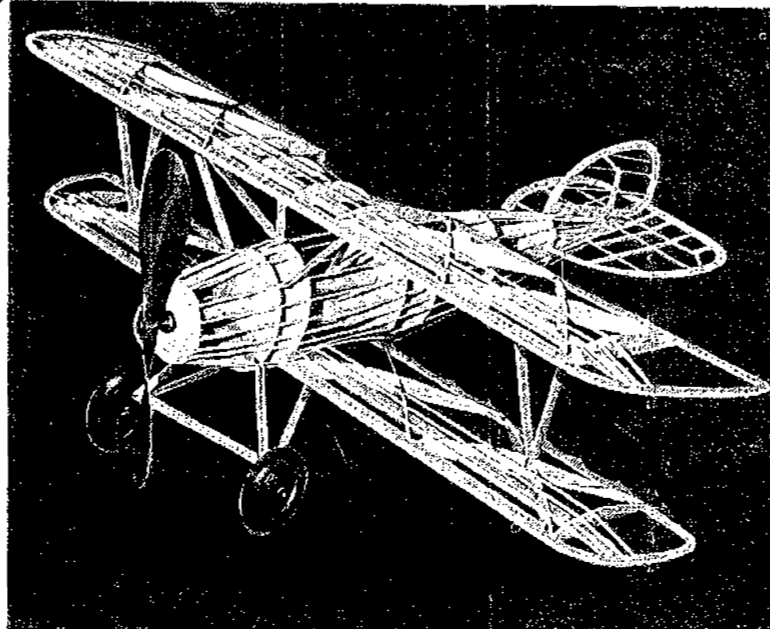

FIG. F

STEP 17
Final assembly (Fig. 16). Fit lower wing onto fuselage between formers B and C, making sure LEI the fit securely under F6 pieces of the fuselage. Glue securely in place. Glue additional stringers below wing and cover. Fit upper wing support wire ends into grooves notched into bottom of leading edge on top wing (Fig. 17). Glue in place, then add hardwood caps over wire to hold. Turn upside down and let dry. Be sure wing is parallel to line of flight. When dry, glue on additional wing supports cut from 1/16" aircraft wood and FIG. F as a pattern. Glue in place (FIG. A). Glue stabilizer and rudder in position. Assemble wheels to landing gear wire (Fig. 4). Cut center wheel wing from scrap balsa using FIG. G as a pattern. Glue to landing gear between wheels. Add additional wheel braces in position. Glue wing braces cut from 1/4" stringer wood to wings where indicated on FIG. B and FIG. C.

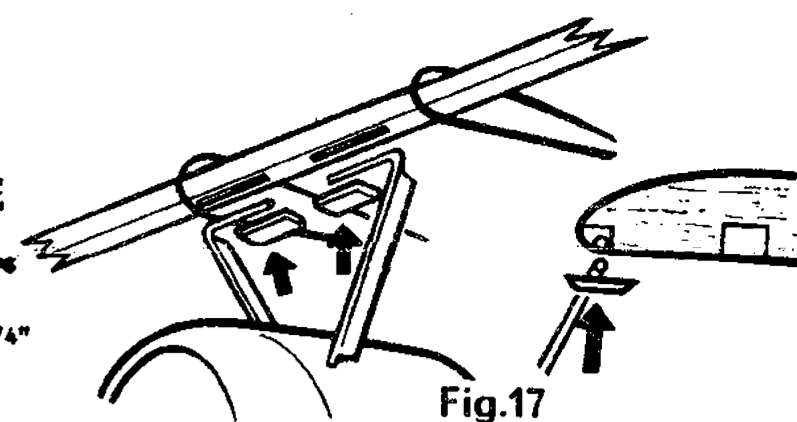

Fig. 17

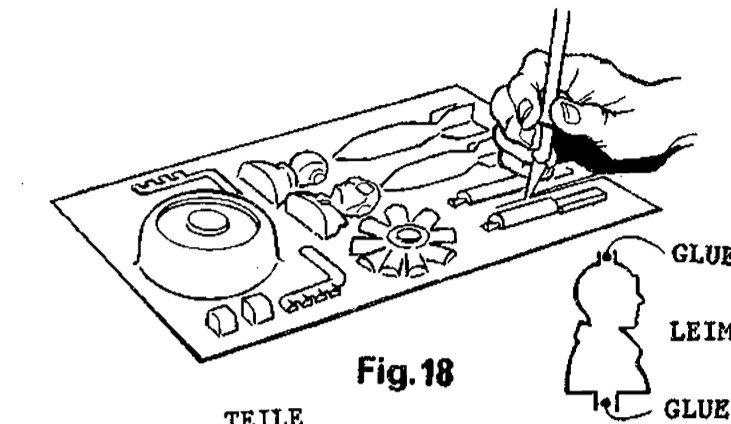

Fig. 18

TEILE PLASTIC PARTS
Your kit contains plastic parts, engineered with a high degree of accuracy, that let you add superb detail to your plane. With a reasonable amount of care in cutting, painting, and application, you will add a new dimension of modeling to your aircraft.

STEP 18
Carefully cut out each piece with a slight "lip" around the part (Fig. 18). This lip lets you glue parts together for a three dimensional look. Parts should be painted with plastic model paint before attaching to model.

COCKPIT-ENGINE COWLING: Needs no lip when cut out. Trim to fit fuselage being careful not to cut away too much. Glue in place.

SIDE PANELS: Needs no lip when cut out. Fit and glue carefully to sides of fuselage in position as shown in FIG. A.

UPPER WING RADIATOR: No lip required. Cut and glue to upper wing as shown on FIG. C.

RADIATOR CAP: Use lip to glue together. Glue to cockpit - engine cowling.

EXHAUST STACK, EXHAUST PORTS AND COOLANT PIPE: Glue to engine cowling where indicated on FIG. 15.

MACHINE GUNS: Use lip to glue halves together. Glue to cockpit-engine cowling.

TAIL SKID: Use lip to glue halves together. Glue to underside of fuselage as indicated in FIG. A.

WING TIPS: Needs no lip when cutting out. Glue to leading and trailing edges of wing, covering trimmed main spar and stringers as in FIG. 11.

PILOT: Glue halves together using lip. Glue in place.

18 PLASTIC TEILE AUSSCHNEIDEN DABEI SCHMALE KANTE STEHON LASSEN (FIG. 18) VOR DEM EINBAU SOLLTEN DIE TEILE BEHALT WERDEN. PILOTENSITZ-MOTOR VERKLEIDUNG OHNE KANTE AUSSCHNEIDEN AN RUMPF ANPASSEN UND AUFLEIMEN. SEITENTEILE OHNE KANTE OBEREN FLÜGEL KÜHLER AUSSCHNEIDEN UND AUFLEIMEN (FIG. C) KÜHLER VERSCHLUS AN KANTEN ZUSAMMEN LEIMEN DANN AUFLEIMEN (FIG. A) DIE AUSSPUFF TEIL E UND F SOWIE KÜH(R)HR G WIE VORGESEHEN EINLEIMEN (FIG. 16) MASCHINENGEWEHRE AUS JE ZWEI HÄLFTEN ZUSAMMENLEIMEN UND AN VORGESEHENER STELLE AUFLEIMEN (FIG. A UND FIG. 16) PILOT ZUSAMMENLEIMEN UND AUFLEIMEN SPORN ZUSAMMENLEIMEN UND AM ENDE DES RUMPFES EINLEIMEN

ALBATROSS DV

FEATURING **SUPERX SPEED** CONSTRUCTION
SPANNWEITE: 711mm
WINGSPAN 28 INCHES
LENGTH 23 INCHES
KIT NO. 2602 LÄNGE: 584mm
DESIGNED BY Jan Rading
COMET INDUSTRIES CORP., Chicago, Illinois 60609 © 1975

PRINTED IN U.S.A.

WING CONSTRUCTION

FLÜGEL

STEP 8
To construct lower wing, cut trailing edge pieces from 1/4" x 1/16" stringer wood, then trim curves on outer edges as shown by dotted lines on FIG. 8. Then pin to plan, laying wax paper down first so pieces can be easily lifted off.

STEP 9
Cut main spar to length and pin to plan (FIG. 8) as indicated. NOTE: Main spar pieces included in kit are not long enough without splicing. Refer to FIG. 7. This splicing technique should also be used later to assemble leading edge.

FLÜGEL AUFBAU

8) UNTEREN FLÜGEL: ENDLEISTE AUS 6x1.5mm RUNDUNGEN AN DEN GESTRICHELTEN LINIEN AUSSCHNEIDEN (FIG. 8) UND MIT STECKNADELN AUF DEM PLAN FESTSTECKEN. (WAXPAPIER UNTERLEGEN UM FESTKLEBEN ZU VERHINDEREN)

9) HAUPTHOLM ZUSAMMEN LEIMEN (SCHÄFTEN FIG. 7) VON LÄNGE SCHNEIDEN UND AUF DEM PLAN FESTSTECKEN (FIG. 8) WIEDERHOLE DASSELBE MIT DER NASENLEISTE

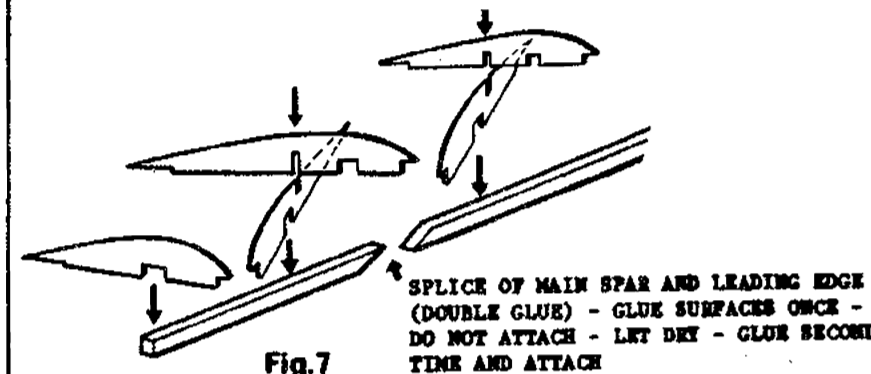

Fig. 7

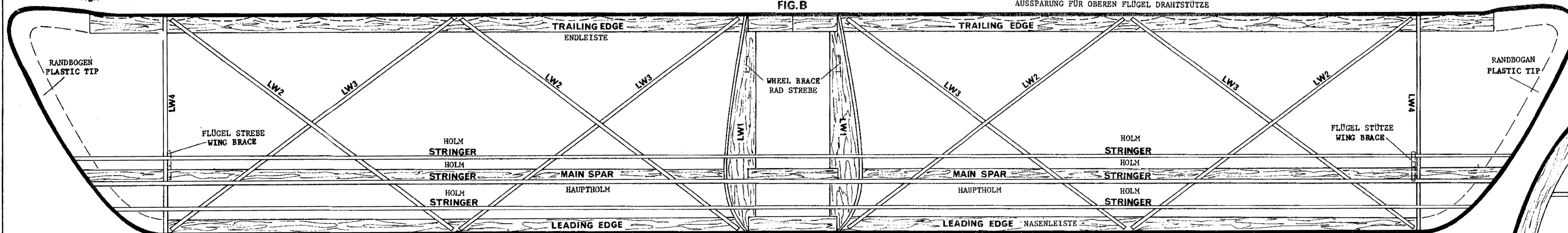
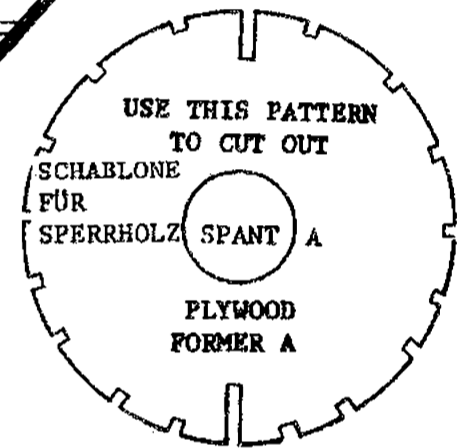

FIG. B

GROOVE FOR UPPER WING SUPPORT WIRE
AUSSPARUNG FÜR OBEREN FLÜGEL DRAHTSTÜTZE



STEP 10
Glue both LW1 and LW4 ribs to main spar and trailing edge as in FIG. 6. Be sure LW1 ribs are at angles shown on FIG. 6.

STEP 11
Now criss cross wing formers LW2 and LW3. Place in position on FIG. B and glue to main spar and trailing edge as in FIG. 8.

STEP 12
Cut leading edge spar to length using 1/4" spar wood (FIG. 8) and glue to front of ribs (FIG. 9). Complete by gluing top stringers into notches, trim off excess when dry. Finish leading edge by trimming excess wood and sanding to rounded edge as in FIG. 10. Trailing edges should also be sanded and rounded at this time. Cut and trim main spar and stringers as in FIG. 11, for plastic tips that are to be added later.

12) NASENLEISTE 6x6mm VON LANGE SCHNEIDEN VOR DIE RIPPEN SETZEN, EINLEIMEN UND FESTSTECKEN (FIG. 9) DANN DIE OBEREN HOLME EINLEIMEN, NACH DEM TROCKNEN ABHEBEN NASENLEISTE MIT SANDPAPIER ABRUNDEN, HAUPT HOLM AVSCHRÄGEN, RANDBÖGEN (PLASTIC) EINLEIMEN, OBEREN HOLM KNICKEN UND AUFLAIMEN (FIG. 11)

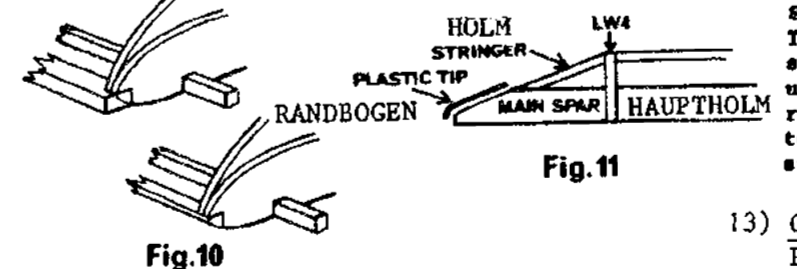

Fig. 10

STEP 13
To construct upper wing (FIG. C), follow the same general directions for the lower wing using UW ribs in place of the lower wing ribs. Glue UW8 pieces to UW9 and then glue to the trailing edges cut from 1/4" x 1/16" stringer wood.

13) OBERER FLÜGEL WIRD NACH DEM SELBEN PRINZIP ZUSAMMEN-GEBAUT (FIG. C)

10) DIE RIPPEN LW1 UND LW4 AUF ENDLEISTE UND HAUPTHOLM LEIMEN LW1 SCHRÄG SETZEN (FIG. 6) FIG. B7

11) DIE RIPPEN LW2 UND LW3 ÜBER KREUZ ZUSAMMEN STECKEN UND EINLEIMEN (FIG. 8)

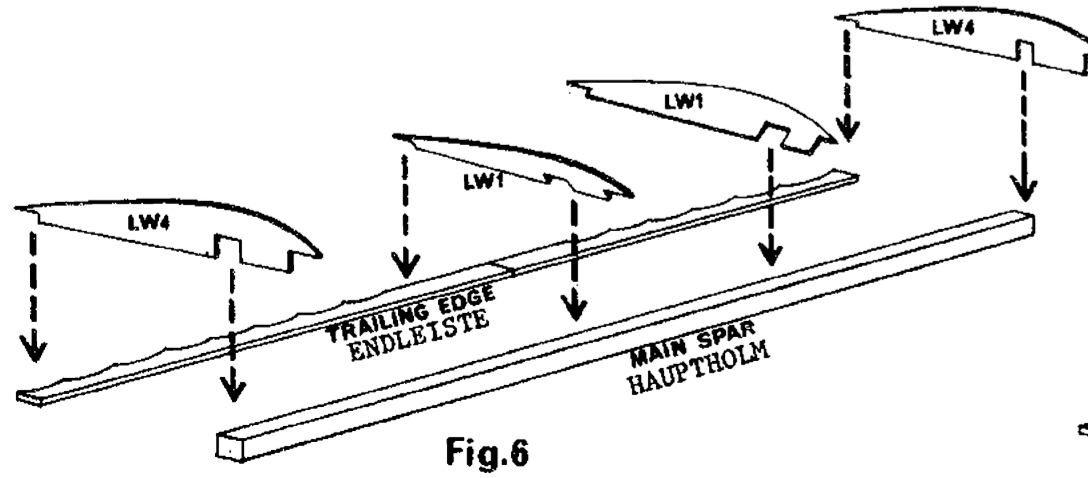

Fig. 6

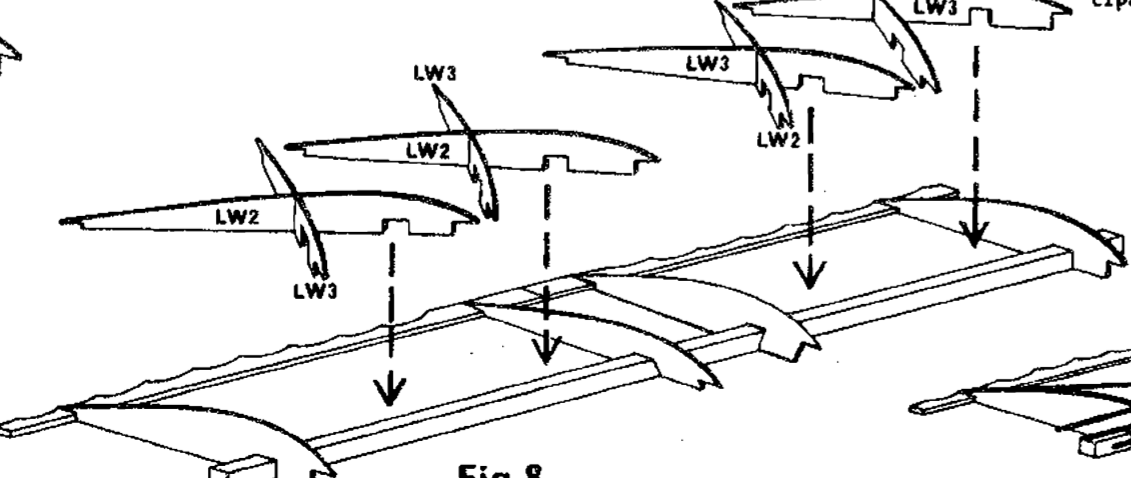

Fig. 8

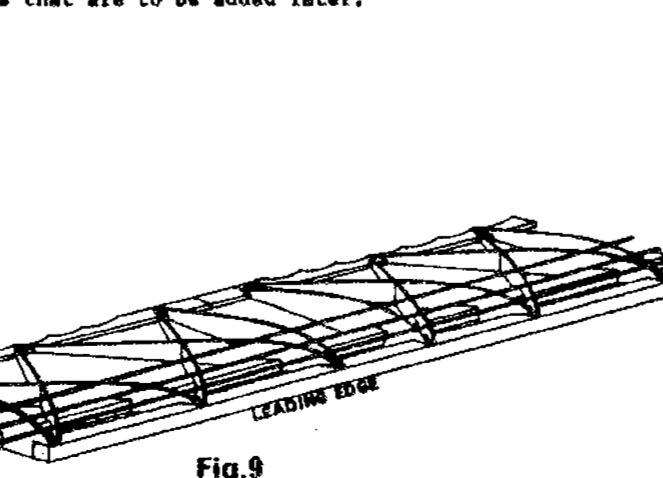

Fig. 9

STEP 14
Glue rudder pieces in place over plan, cut cross bracing from 1/16" stringer wood to fit as shown (FIG. A). Glue stabilizer pieces in position as in FIG. D. Again cut cross bracing from 1/16" stringer wood to fit as shown.

STEP 15
Now sand fuselage, wings, rudder and stabilizer pieces lightly so that no sharp edges protrude on surfaces that are to be covered with tissue (or other material such as silk, silk span, etc.)

Now continue with STEP 16. FORTSETZEN MIT

SEITEN RUDER UND HÖHENRUDER
RUDDER AND STABILIZER CONSTRUCTION

HÖHEN UND SEITENRUDER
14) HÖHENRUDER (FIG. D) DIE TEILE S1, S2 UND S3 AUF DEM PLAN FESTSTECKEN UND VERLEIMEN, LEISTEN 1,5x1.5mm EINPASSEN UND EINLEIMEN. SEITENRUDER WIRD AUF DIESELBE WEISE ZUSAMMENGEBAUT (FIG. C)

15) RUMPF MIT SANDPAPIER SCHLEIFEN SO DASS KEINE SCHARFEN KANTEN HERVORSTEHEN SEITEN UND HÖHENRUDER KANTEN LEICHT SCHLEIFEN UND KANTEN LEICHT ABRUNDEN UND MIT PAPIER BESPANNEN

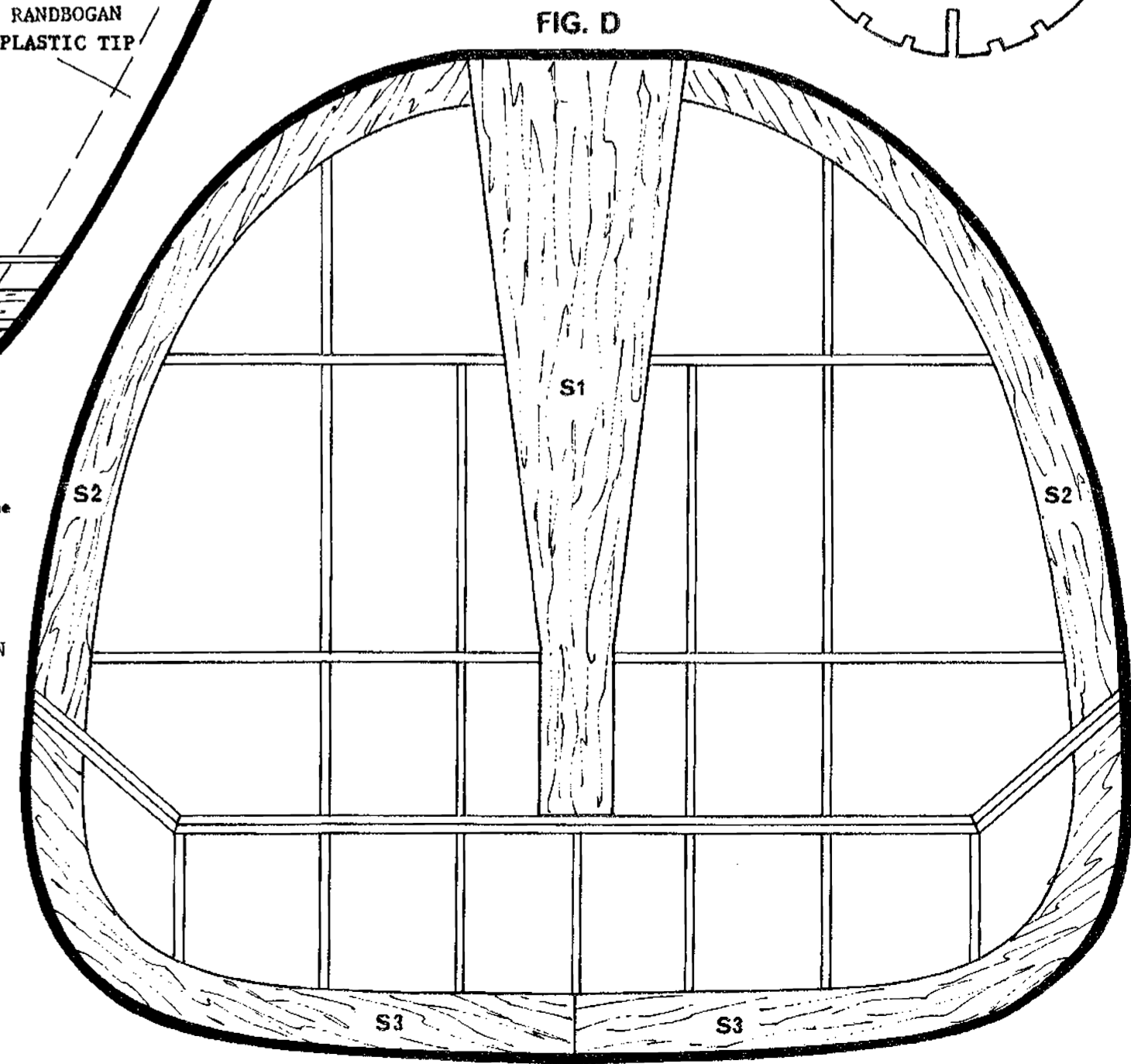

FIG. D