

SECTION AT FORMER 3

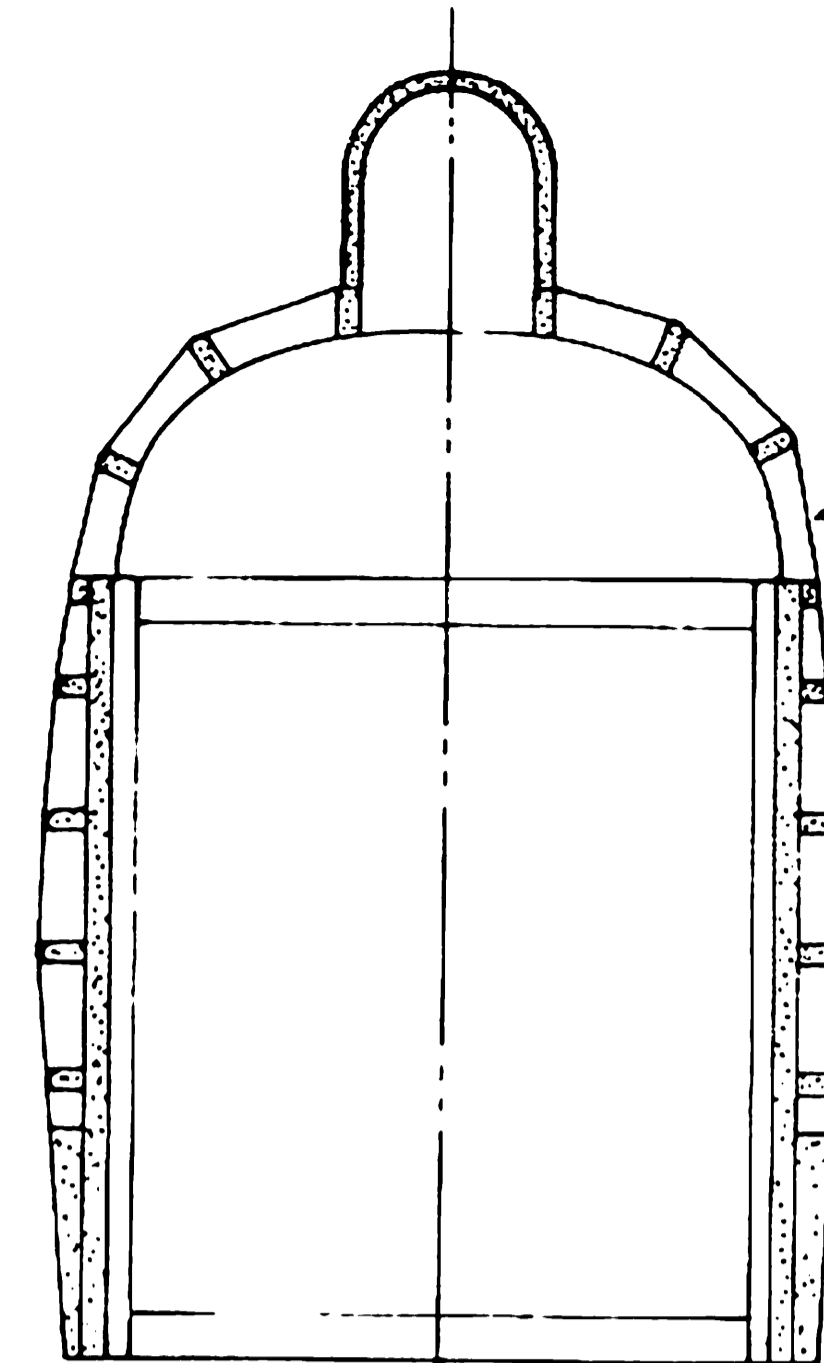

SECTION AT FORMER 7

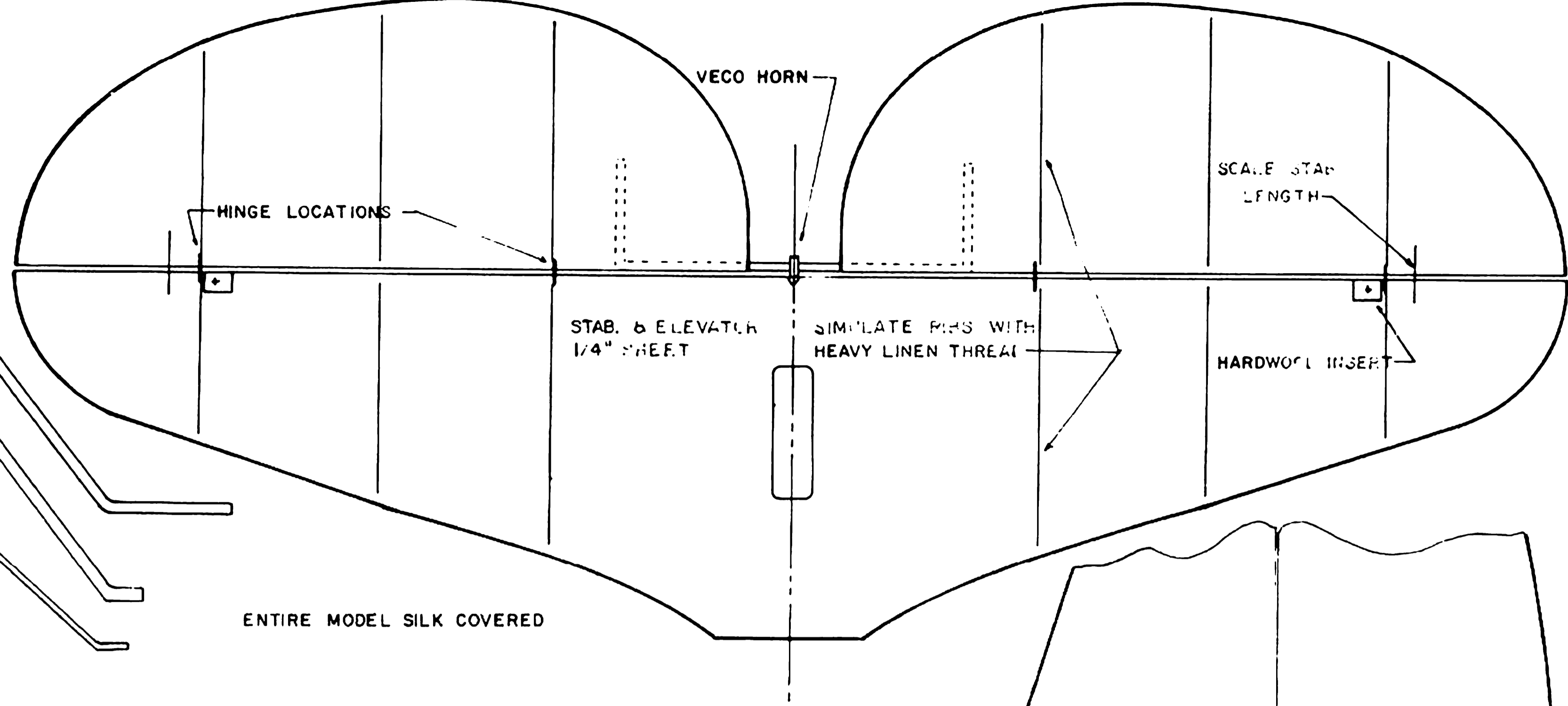
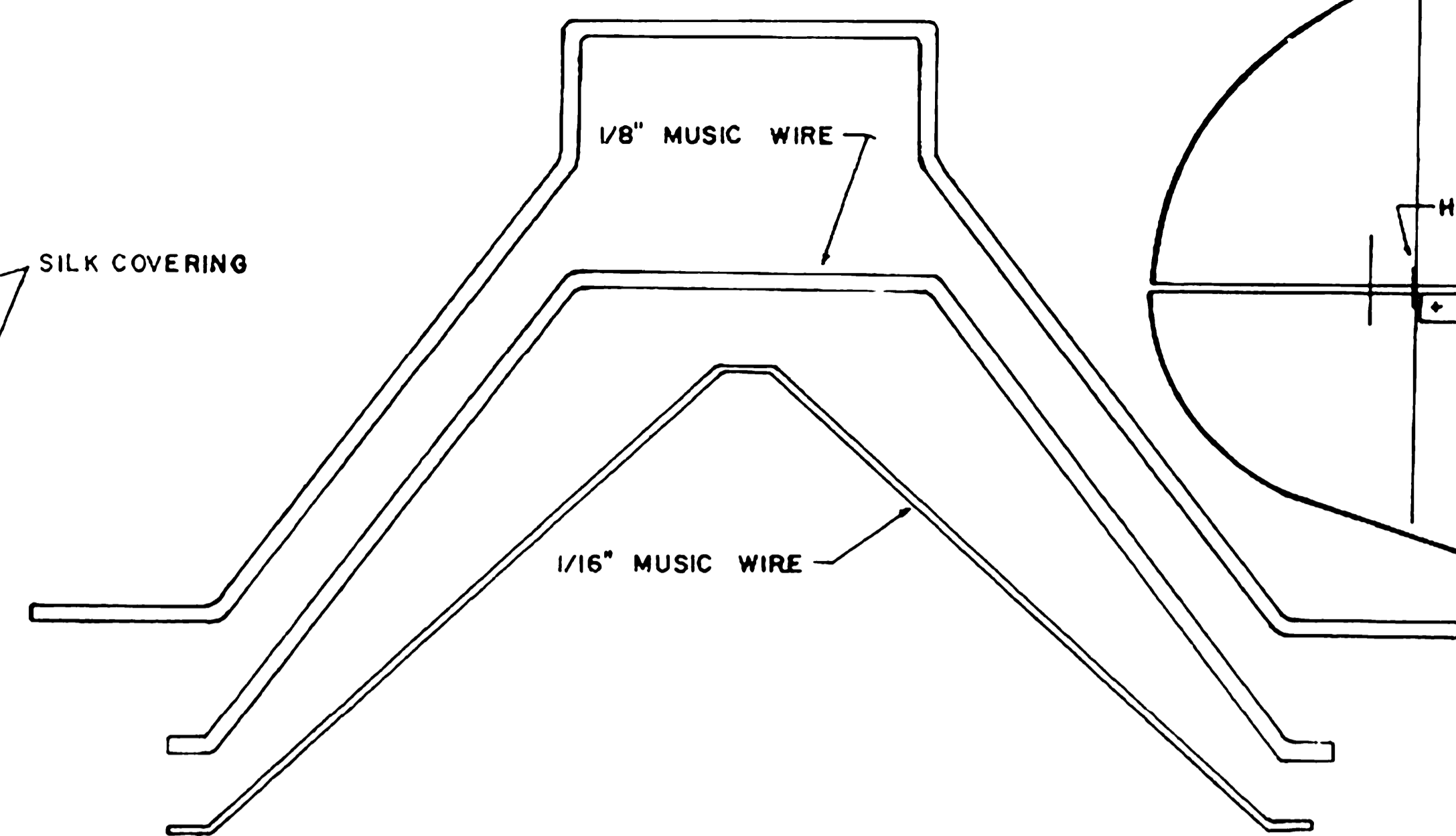

ENTIRE MODEL SILK COVERED

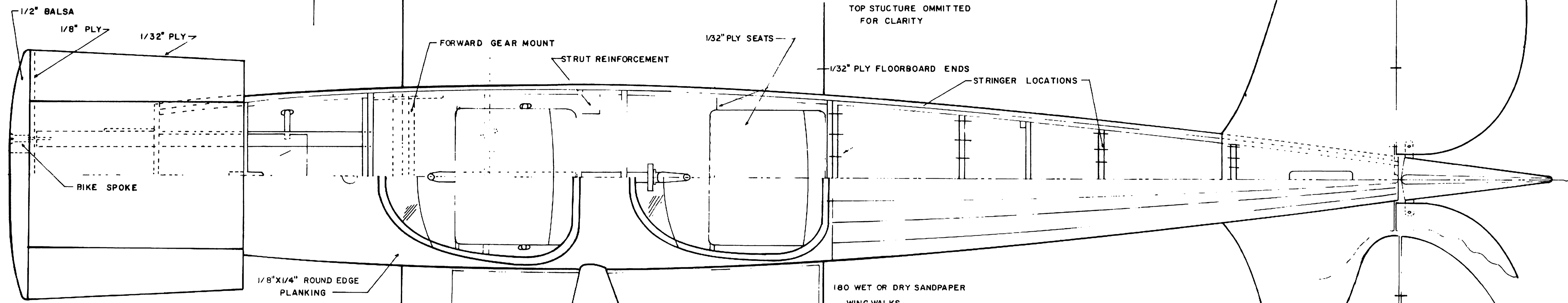

TOP STRUCTURE OMITTED FOR CLARITY

SEE COWL CROSS SECTION

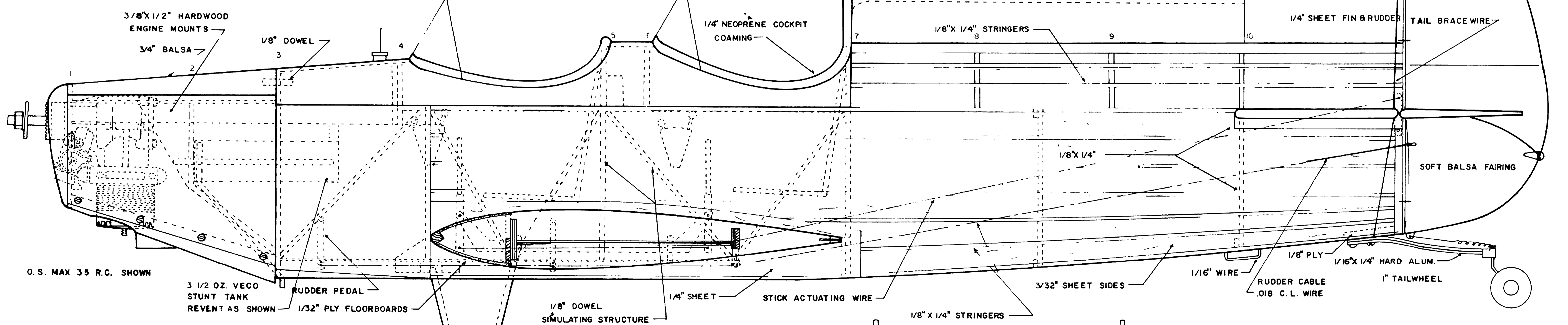

O.S. MAX 35 R.C. SHOWN

3 1/2 OZ. VECO STUNT TANK REVENT AS SHOWN

BUILD UP FROM 1/4" SHEET

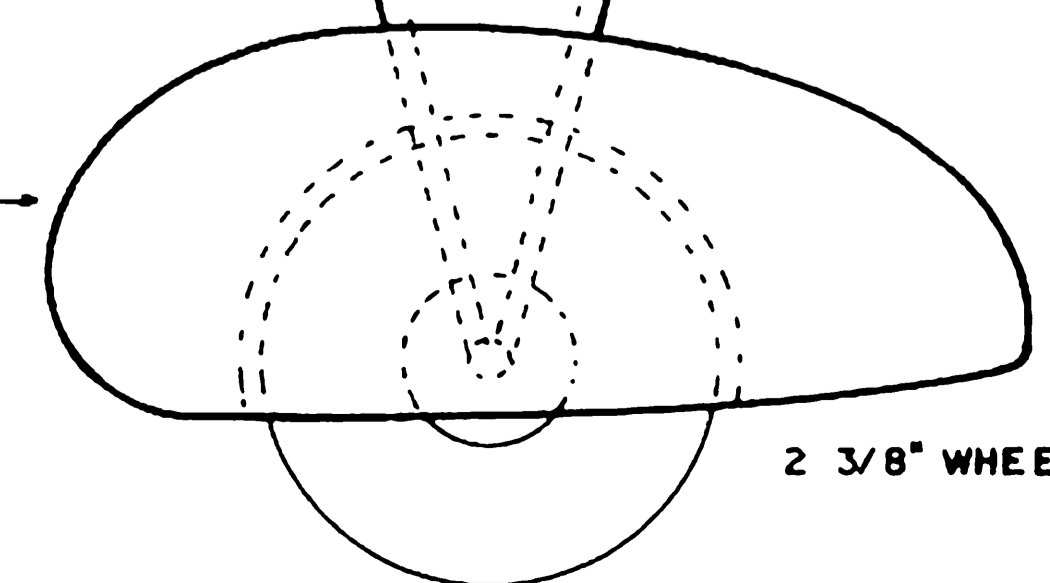
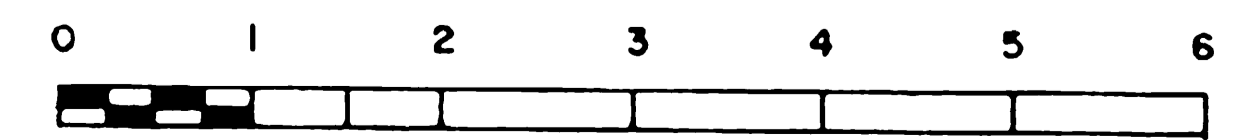

2 3/8" WHEELS

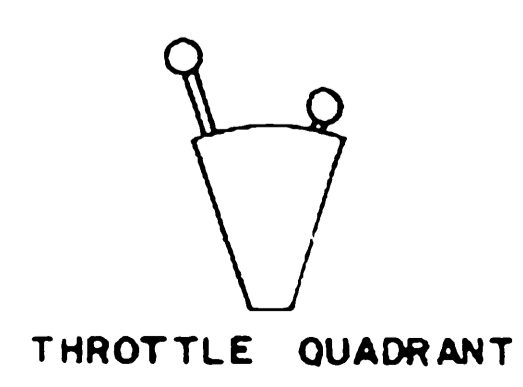

THROTTLE QUADRANT

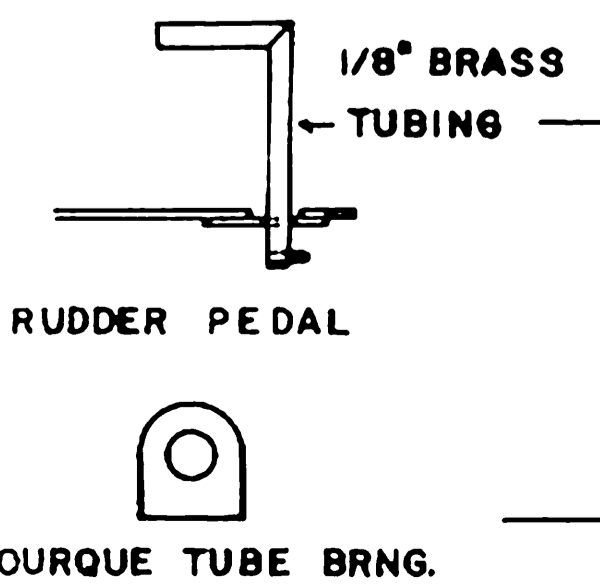

RUDDER PEDAL

TORQUE TUBE BRNG.

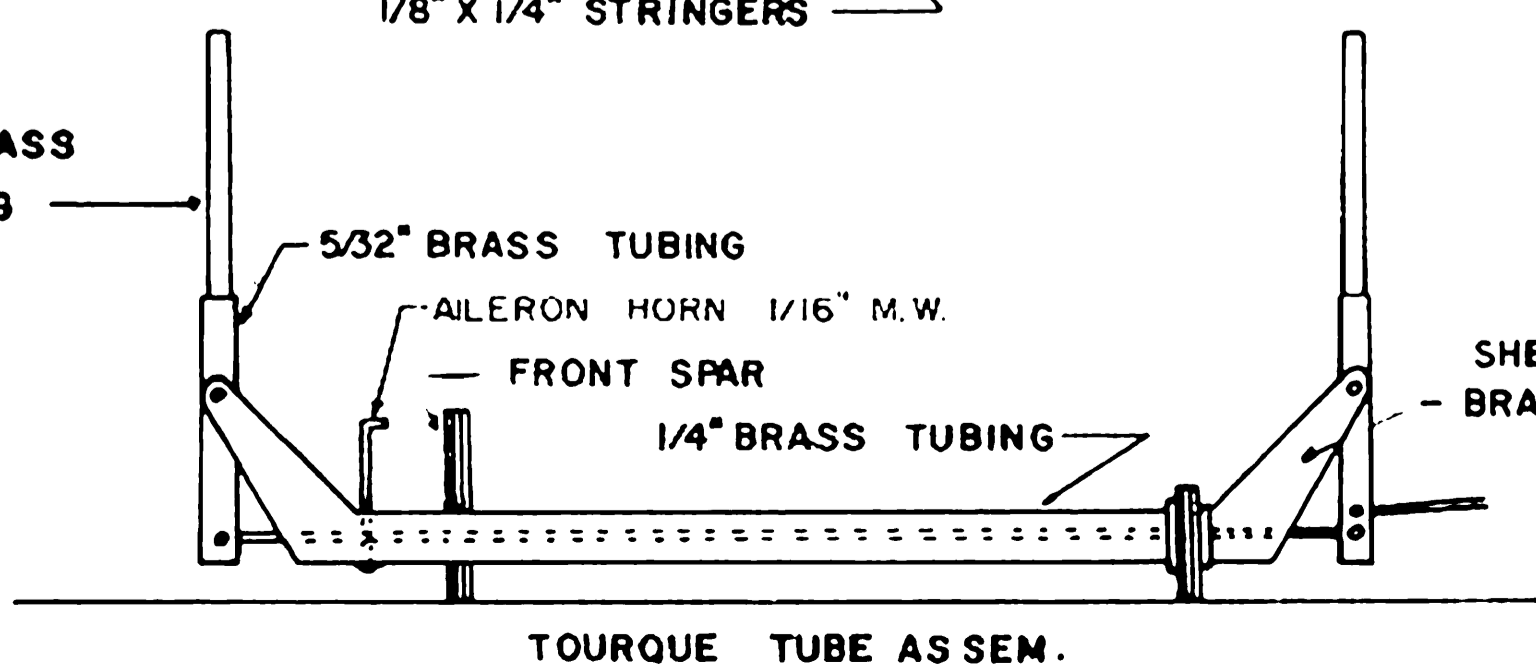

TORQUE TUBE ASSEM.

**SPEZIO SPORT DAL-1**  
**"TUHOLER"**  
 PLATE ONE  
 SCALE 1/16  
 DESIGNED & DRAWN BY  
 CLARENCE HAUGHT

1/8" Balsa Formers

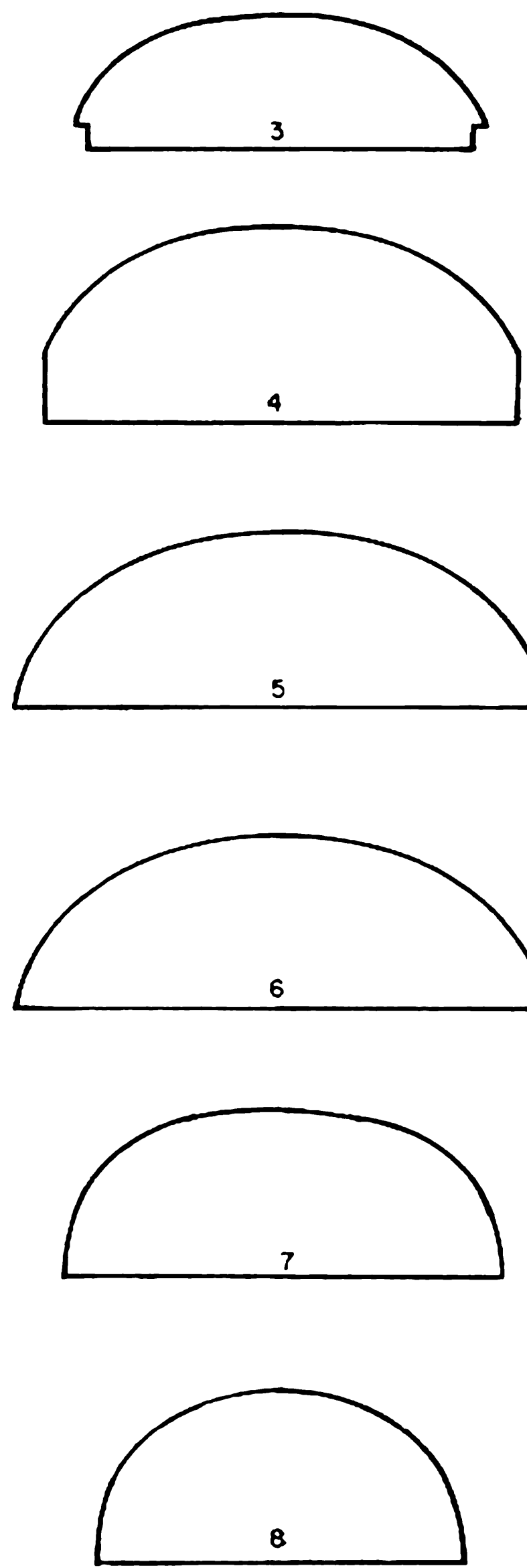

018 CONTROL LINE WIRE TAIL BRACING

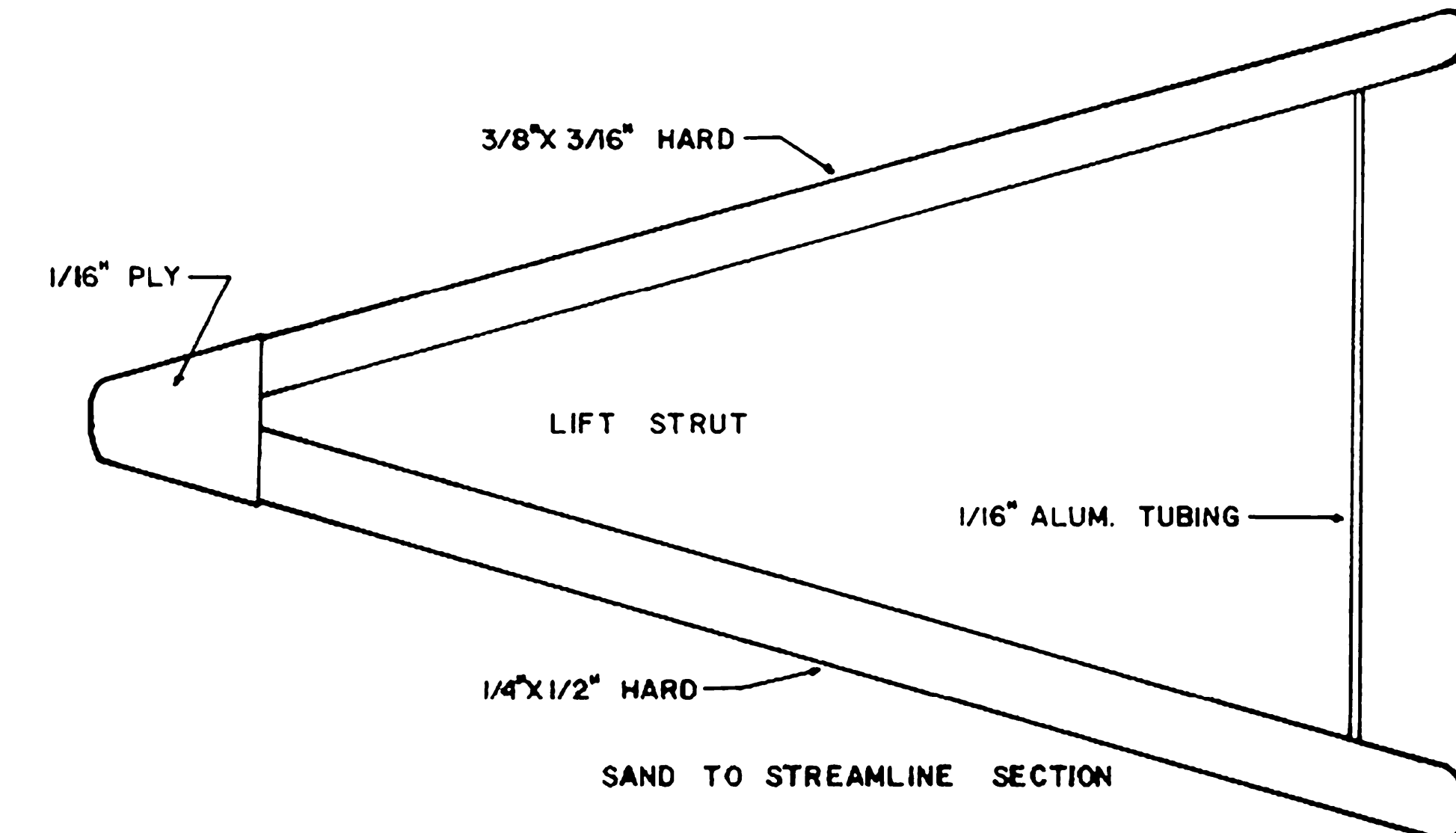
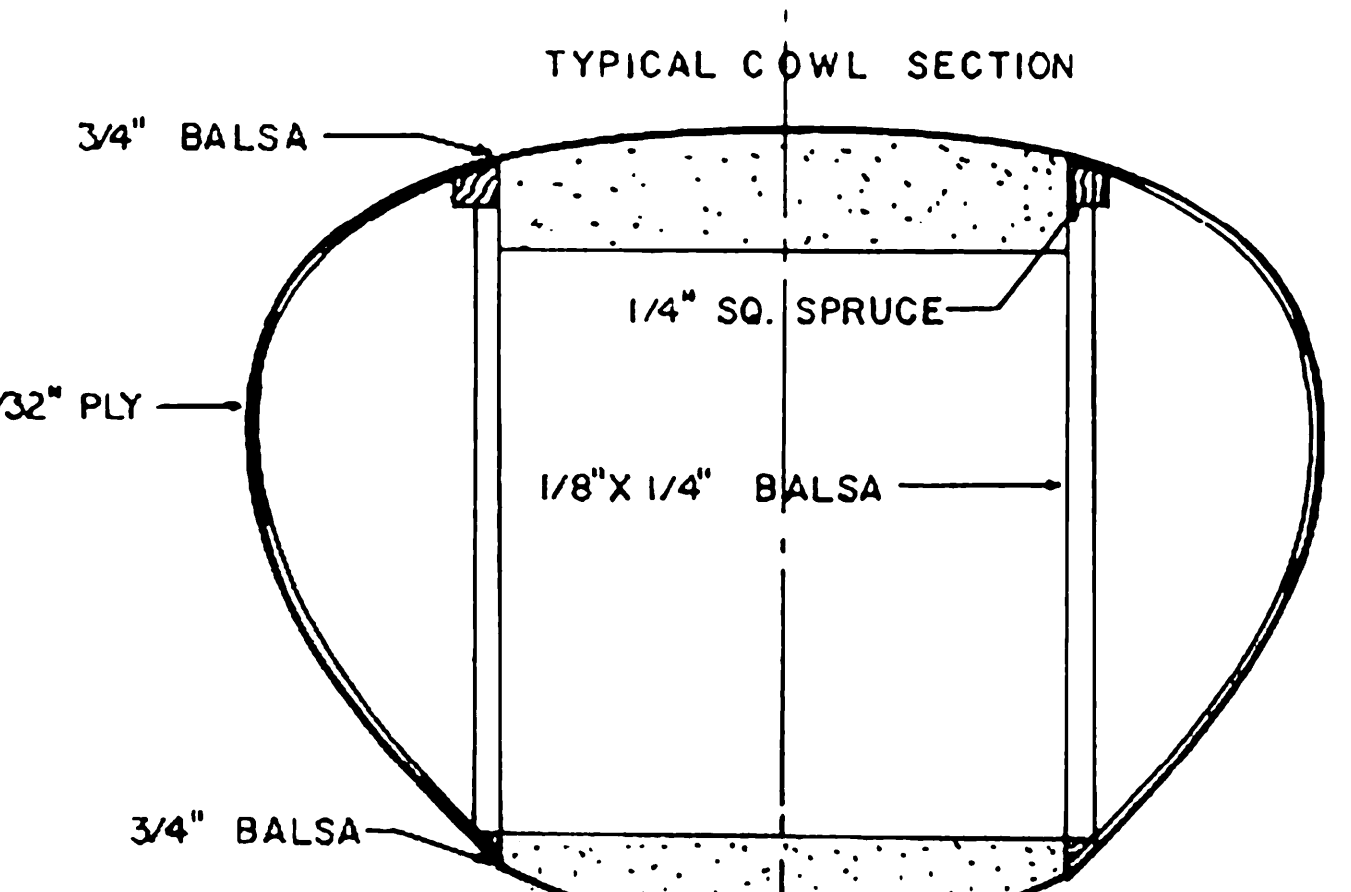
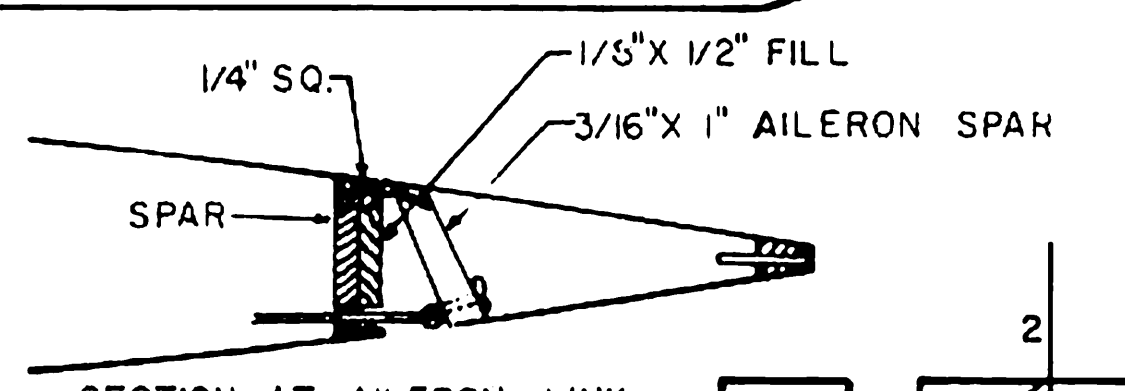
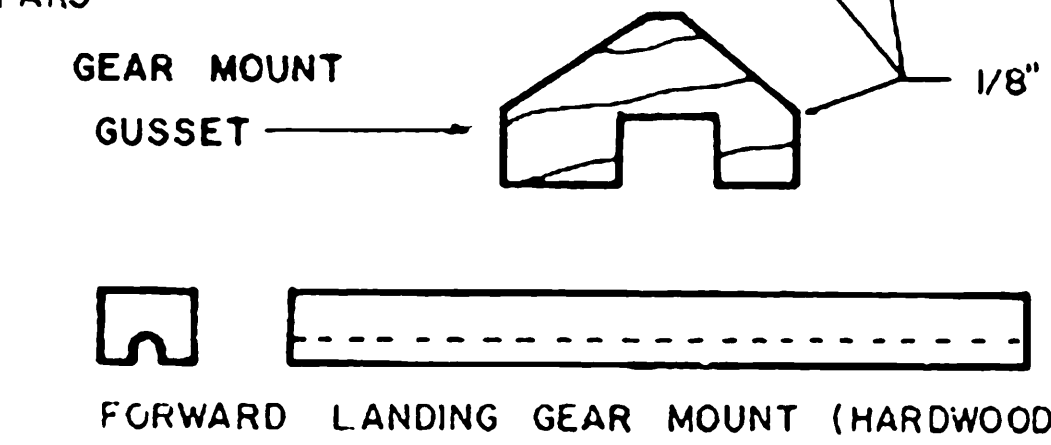
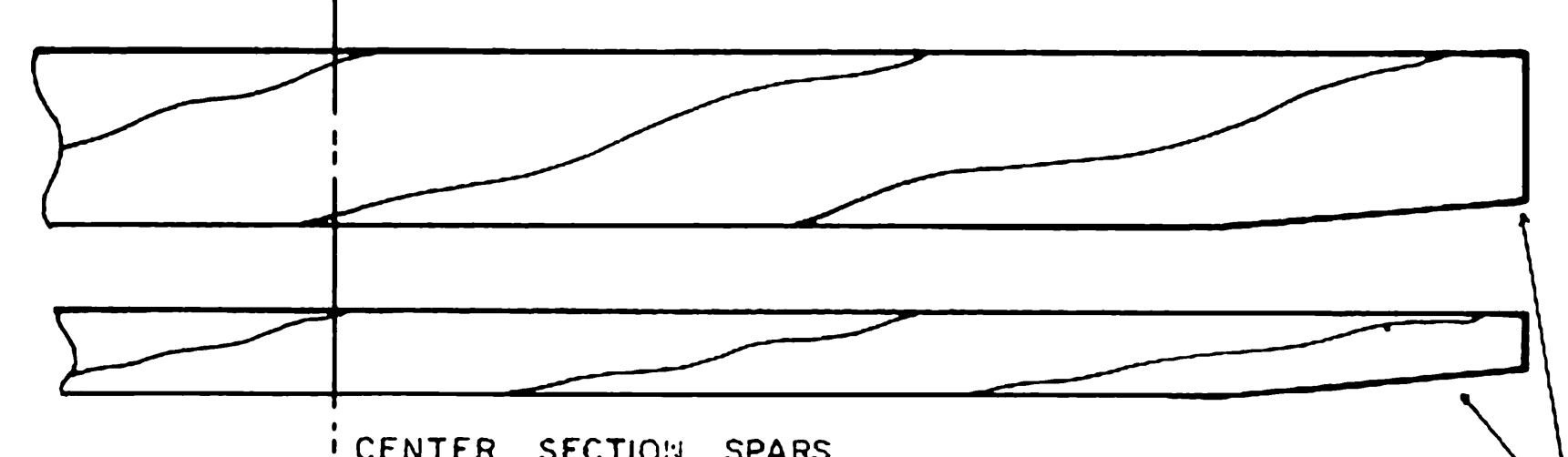
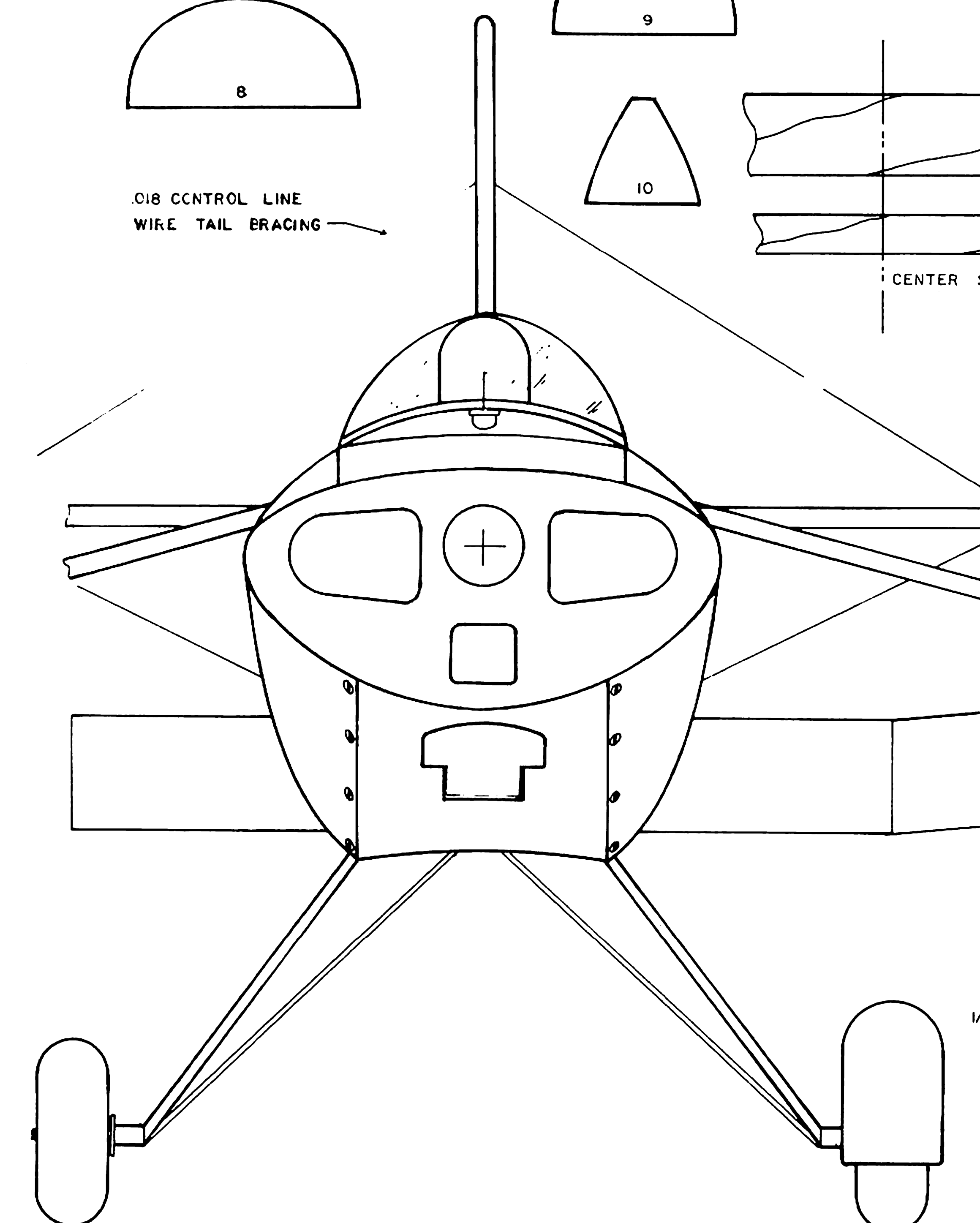
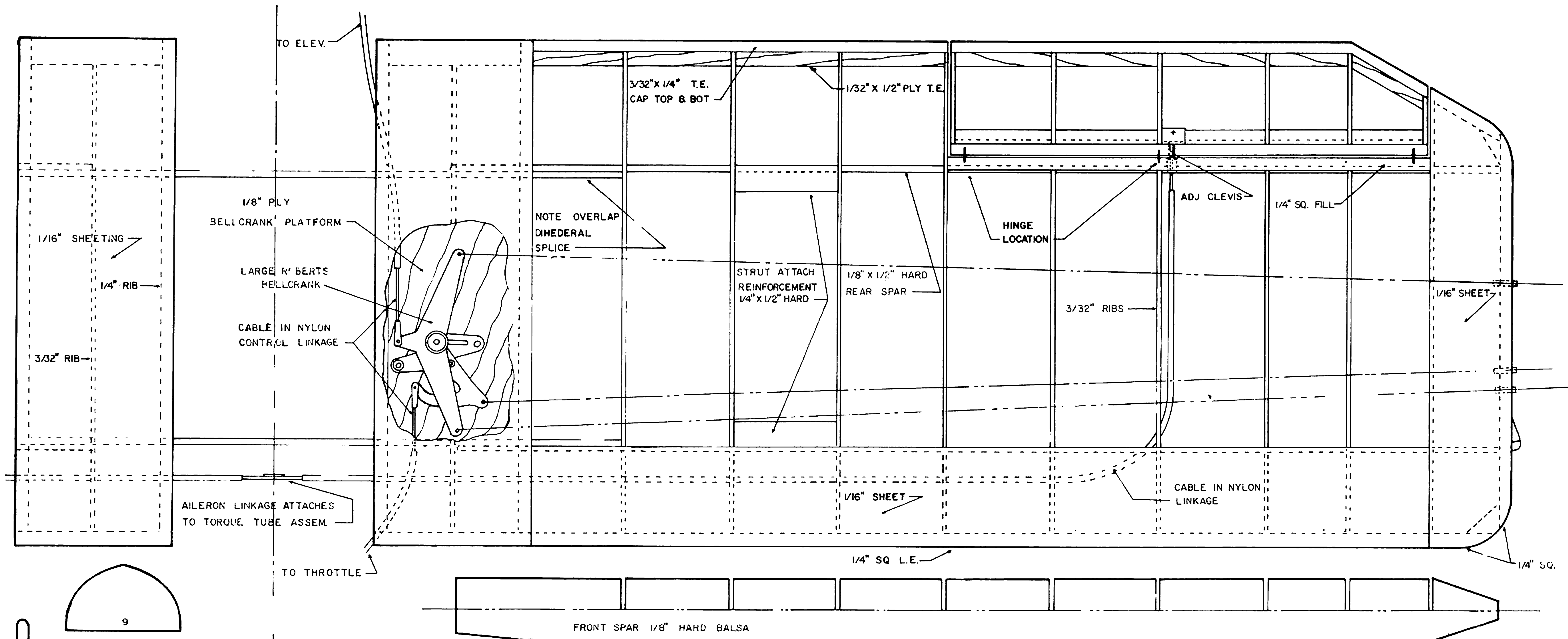

**SPEZIO SPORT DAL-1**  
**"TUHOLER"**  
 PLATE TWO  
 SCALE 1/6  
 DESIGNED & DRAWN BY  
 CLARENCE HAUGHT