

RCM&E PLANS SERVICE
myhobbystore.com
 Tel: 0844 848 8822
 Email: customer.services@myhobbystore.com

DRAGON DANCER 2
 DESIGNED BY PETER MILLER

PLAN No: RC2111	No. OF SHEETS: 1 OF 2	First published in RCM&E Dec. 2012
-----------------	-----------------------	------------------------------------

A 45" SPAN SPORT AEROBATIC MODEL FOR .25 TO .32 cu.in. TWO-STROKE ENGINES

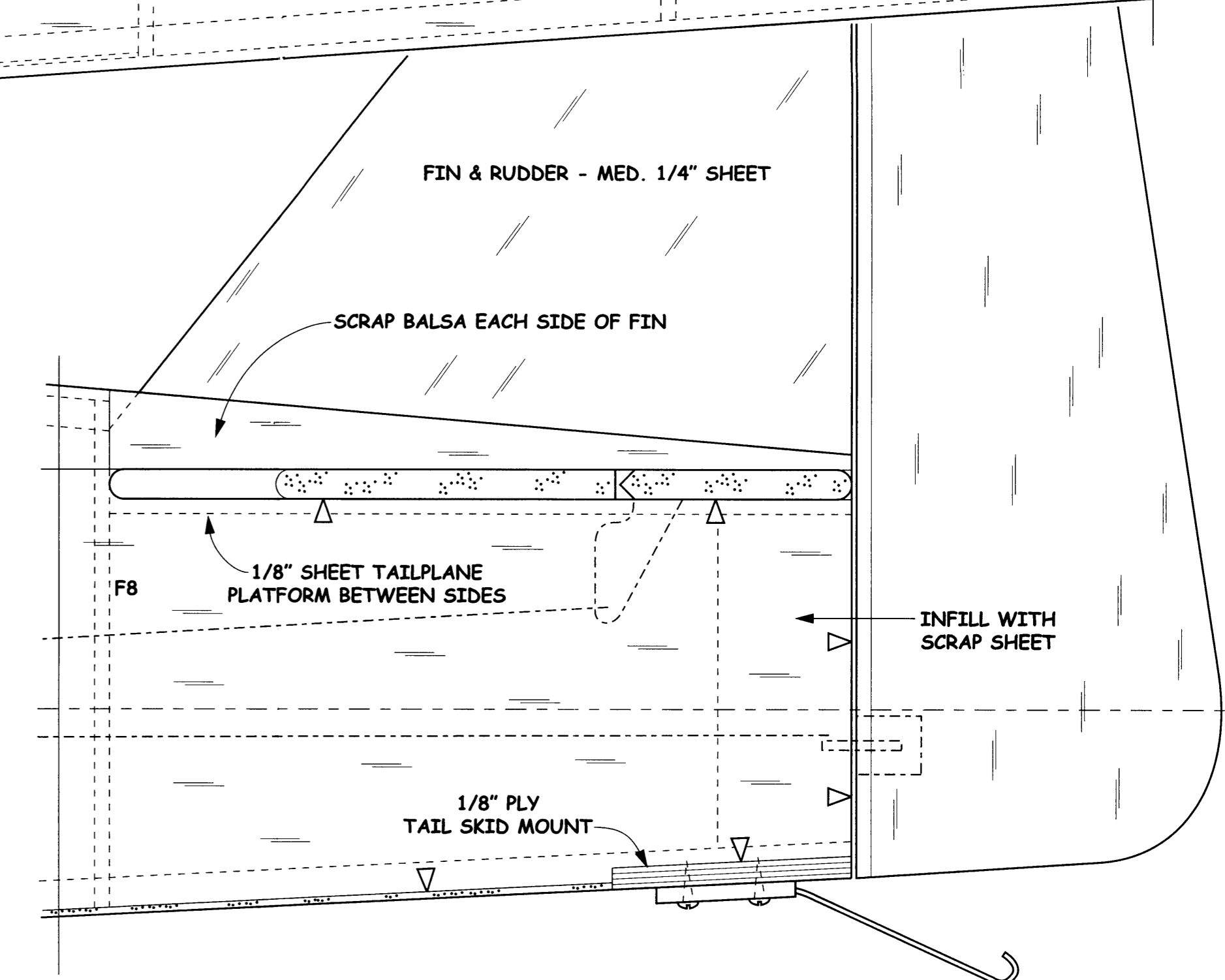
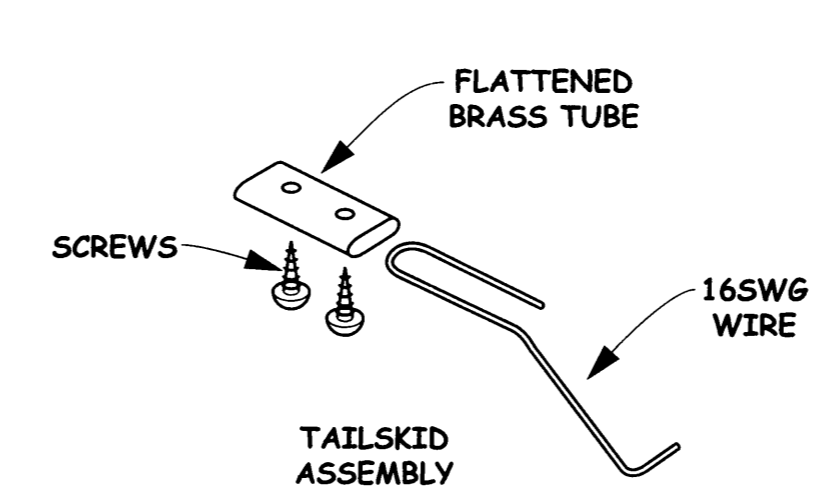
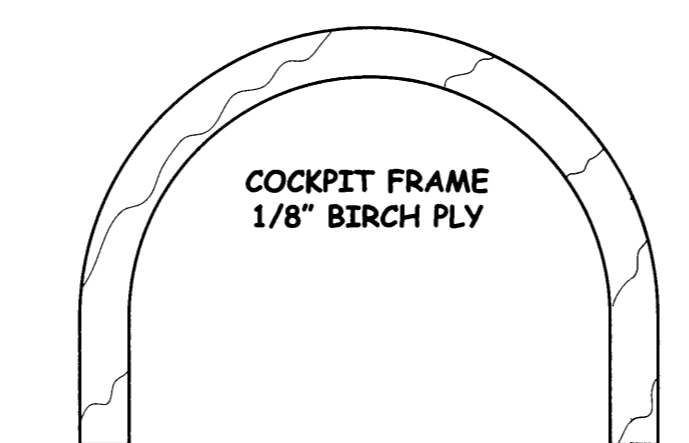
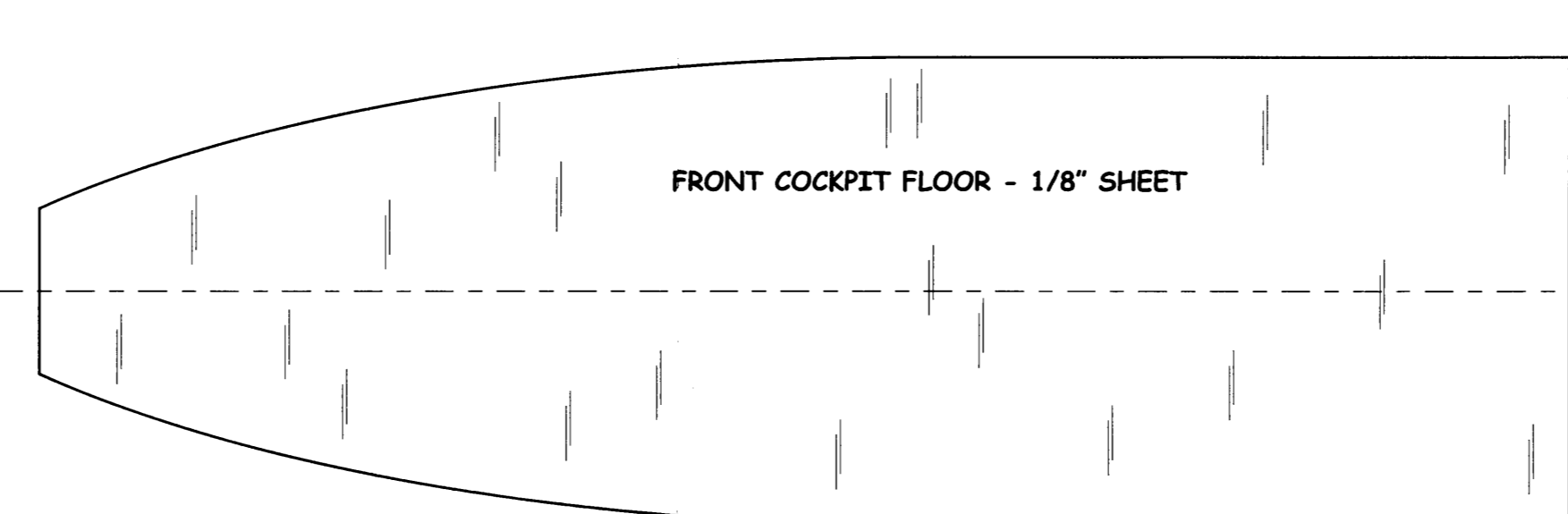
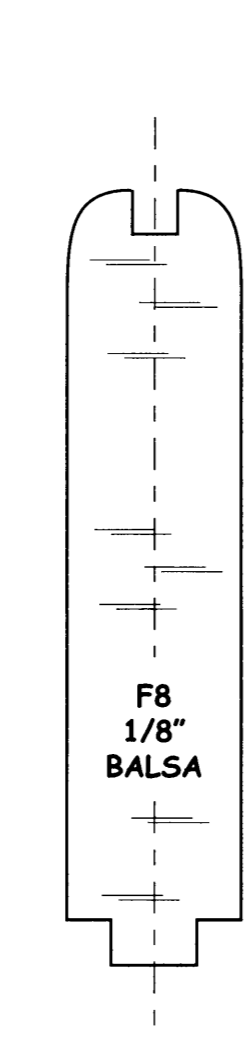
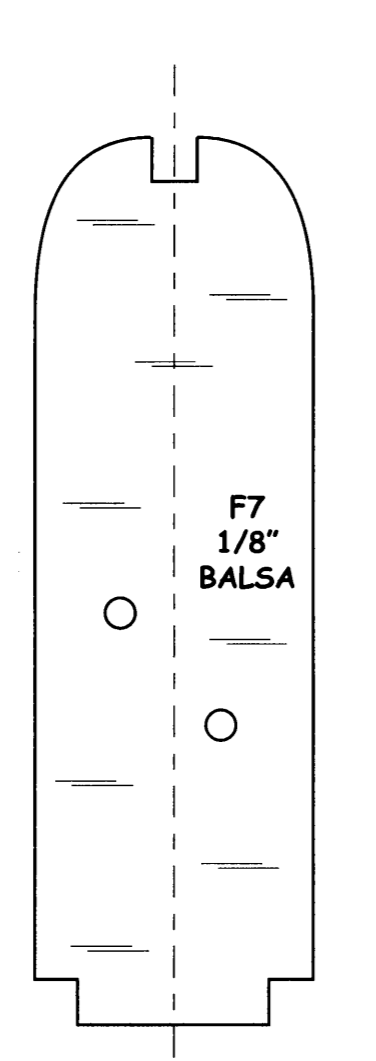
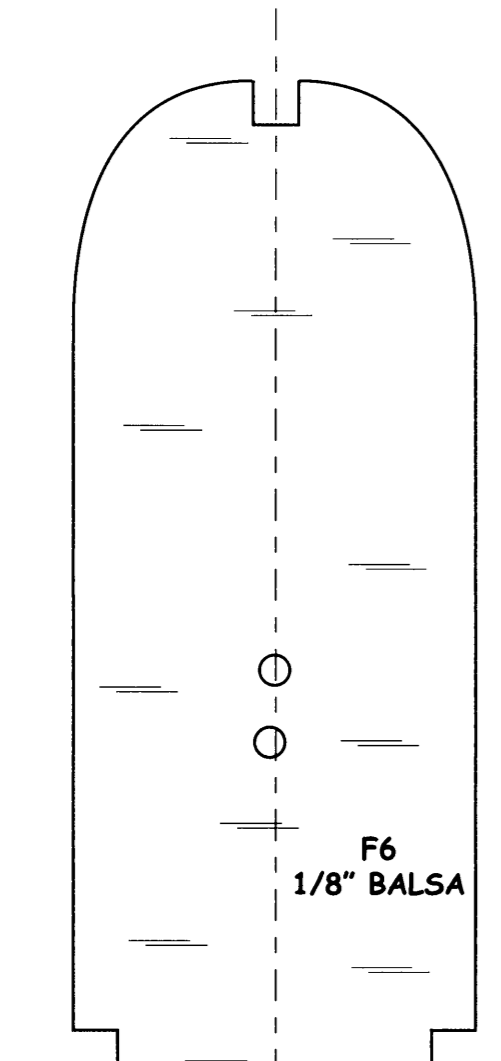
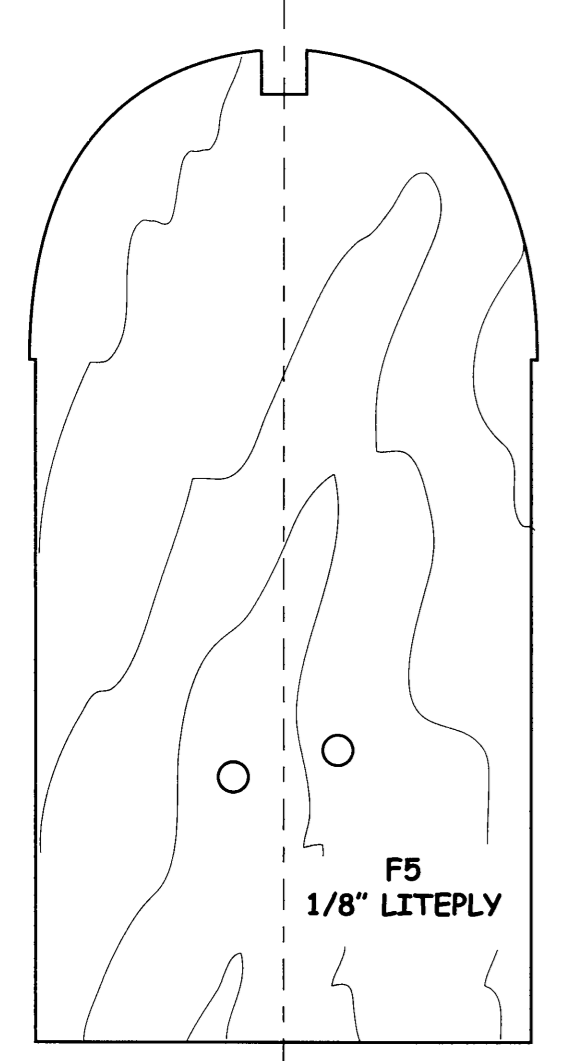
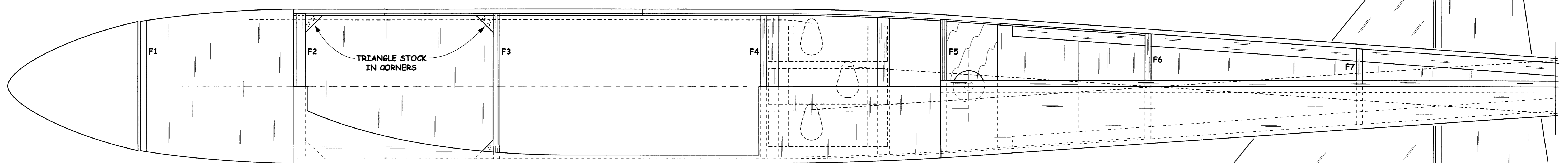
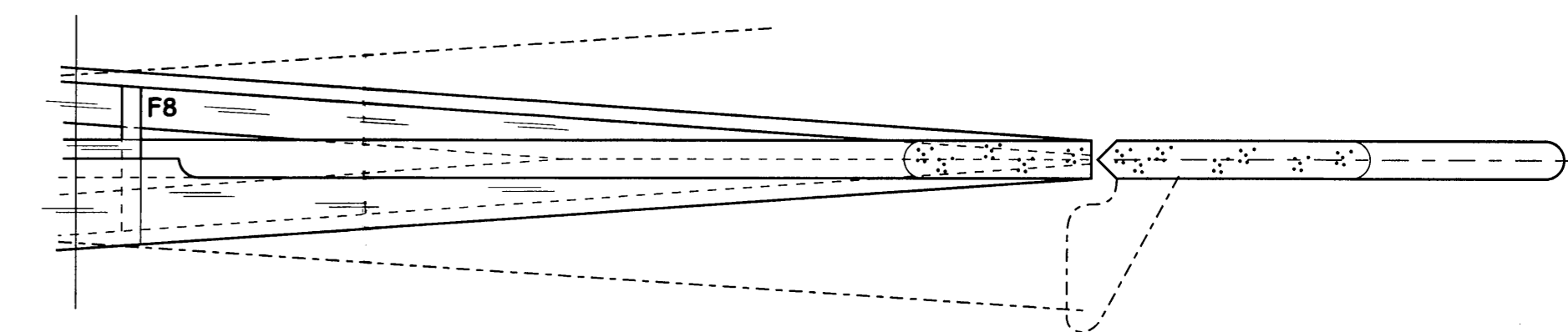

WING IS BUILT FLAT - NO DIHEDRAL

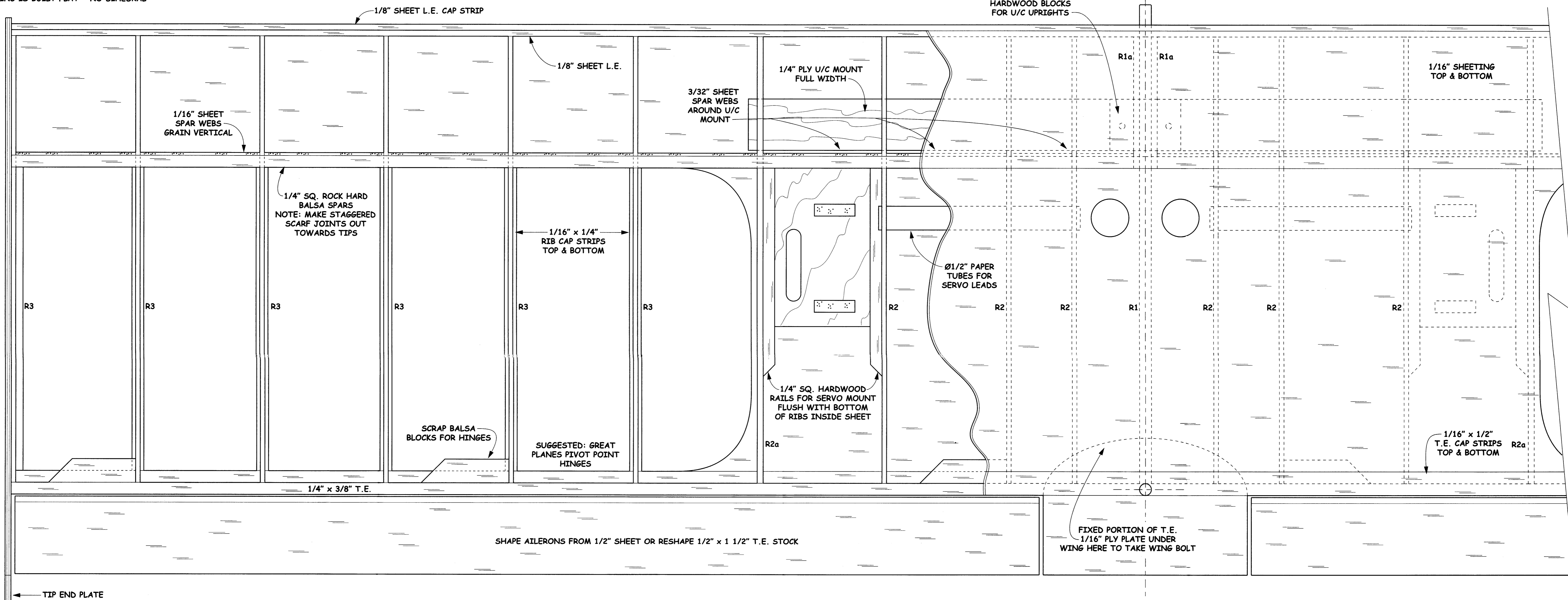

TIP END PLATE

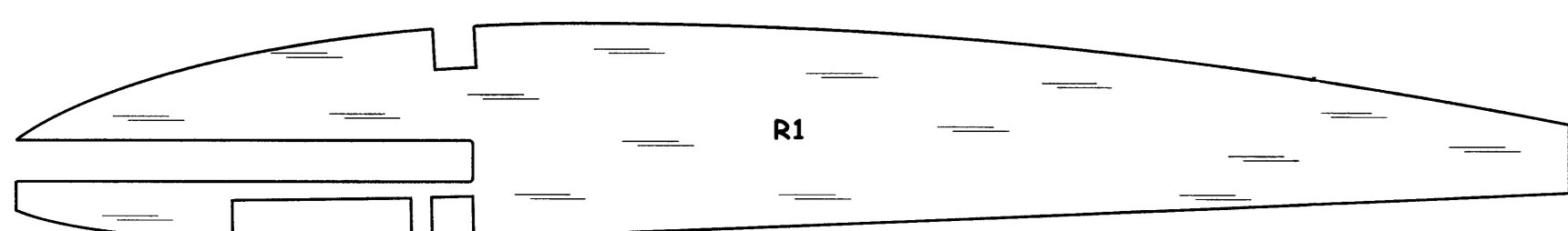

NOTE - SLOT FORMS HOLE FOR WING DOWEL WHEN R1a's ARE LAMINATED ON

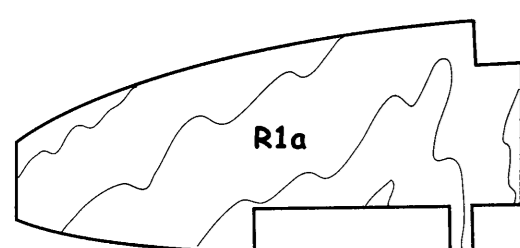

- R1 - HARD 1/4" Balsa, 1 OFF
- R1a - 1/8" LITEPLY, 2 OFF
- R2 - 3/32" Balsa, 6 OFF
- R2a - 1/8" LITEPLY, 2 OFF
- R3 - 3/32" Balsa, 12 OFF

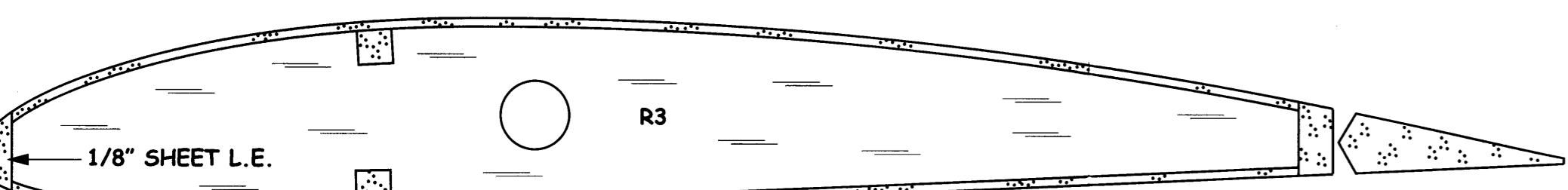
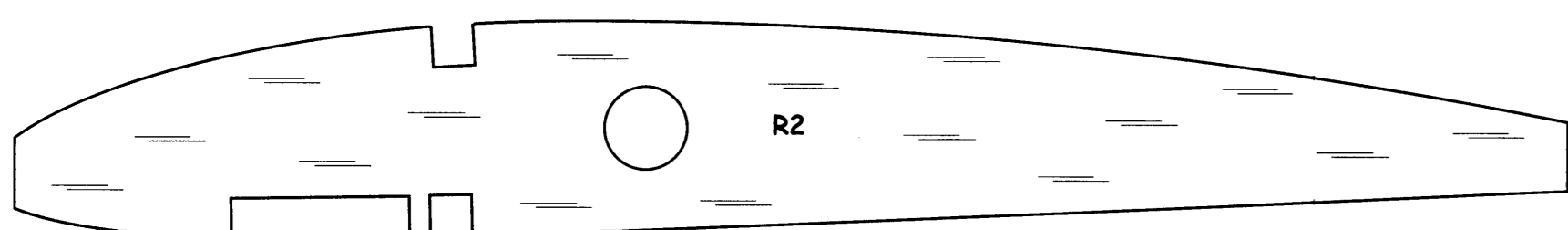

1/8" SHEET L.E. CAP STRIP

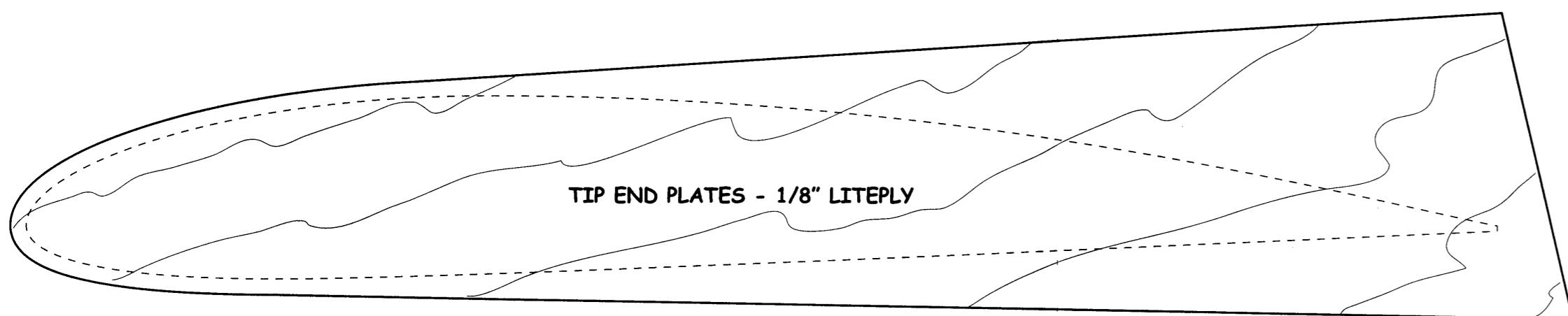

TIP END PLATES - 1/8" LITEPLY

WING BUILDING SEQUENCE:

- 1 - LAY DOWN LOWER L.E. SHEET, T.E. CAP STRIP & RIB CAP STRIPS. GLUE DOWN LOWER MAINSPAR. LAY DOWN BUT DO NOT GLUE U/C MOUNT.
- 2 - THREAD PAPER TUBES THROUGH CENTRE RIBS. GLUE ALL RIBS TO MAINSPAR & CAP STRIPS.
- 3 - GLUE ON TOP MAINSPAR, 1/8" SHEET L.E. & 1/4" x 3/8" T.E. RAISE U/C MOUNT FULLY INTO SLOTS IN RIBS & GLUE IN PLACE.
- 4 - RAISE L.E. SHEET & GLUE TO RIBS & L.E. GLUE IN SPAR WEBS.
- 5 - GLUE ALL BLOCKS FOR U/C UPRIGHTS & HINGES. GLUE IN SERVO MOUNT RAILS. TRIM L.E. & T.E. TO MATCH RIBS. FIT ALL TOP SHEETING & CAP STRIPS.
- 6 - LIFT WING FROM BOARD & ADD L.E. CAP STRIP, THEN SHAPE TO MATCH WING.

Ø1/8" MUSIC WIRE LANDING GEAR. MAKE ONE RIGHT & ONE LEFT, SEE FUSELAGE SIDE VIEW FOR RAKE ANGLE

RCM&E PLANS SERVICE
myhobbystore
 Tel: 0844 848 8822
 Email: customer.services@myhobbystore.com
DRAGON DANCER 2
 DESIGNED BY PETER MILLER
 PLAN No: RC2111 No. OF SHEETS: 2 OF 2 First published in RCM&E Dec. 2012

A 45" SPAN SPORT AEROBATIC MODEL FOR .25 TO .32 cu.in. TWO-STROKE ENGINES

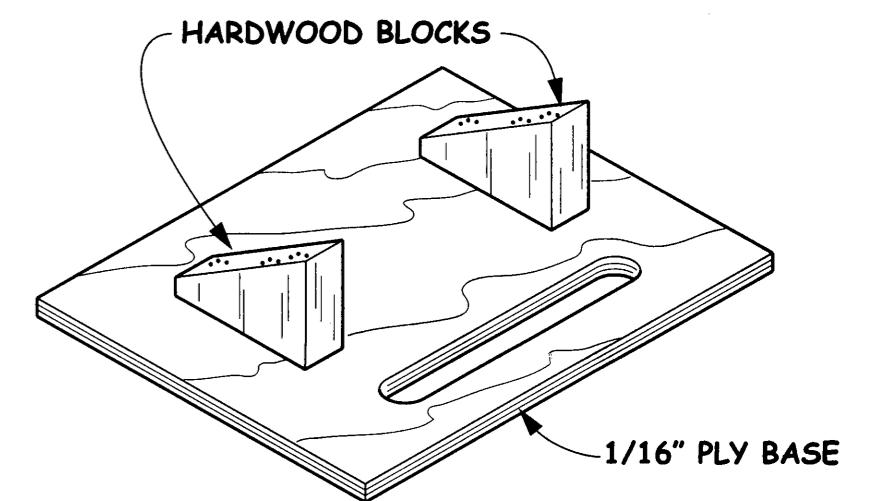

SERVO MOUNTS

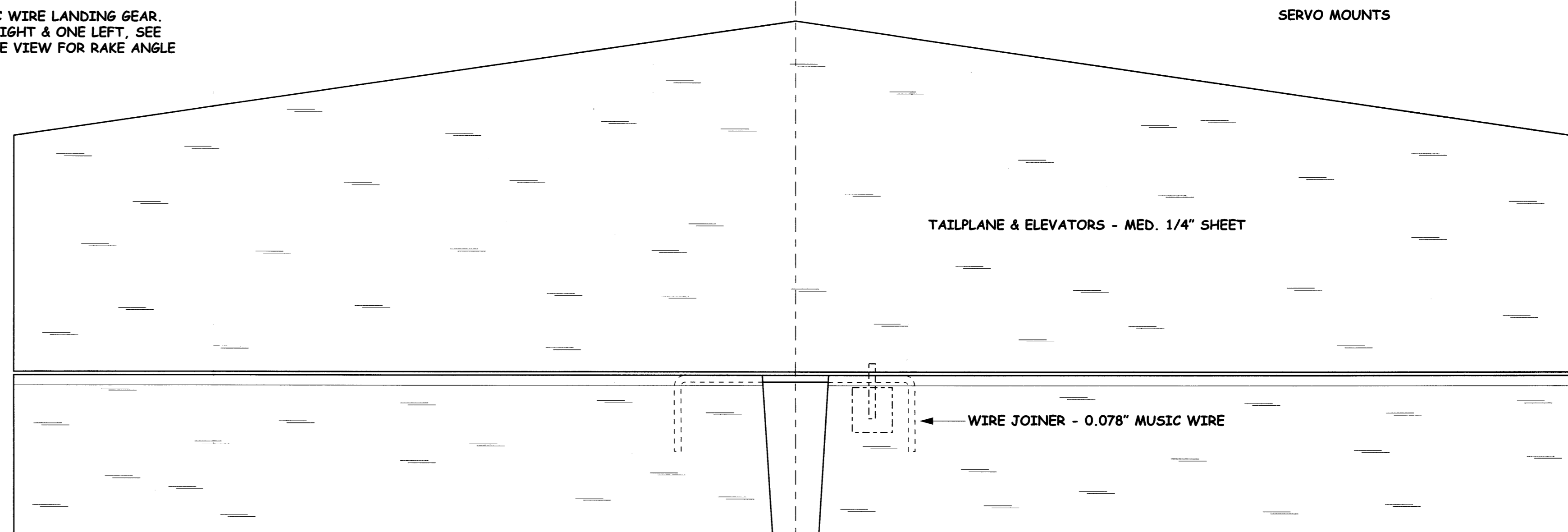

TAILPLANE & ELEVATORS - MED. 1/4" SHEET

WIRE JOINER - 0.078" MUSIC WIRE