

For full size plans send \$8.95 to
 Harold Parenti, 1920 Buckingham Ave.,
 Westchester, Illinois 60153.

MANUFACTURING NOTES

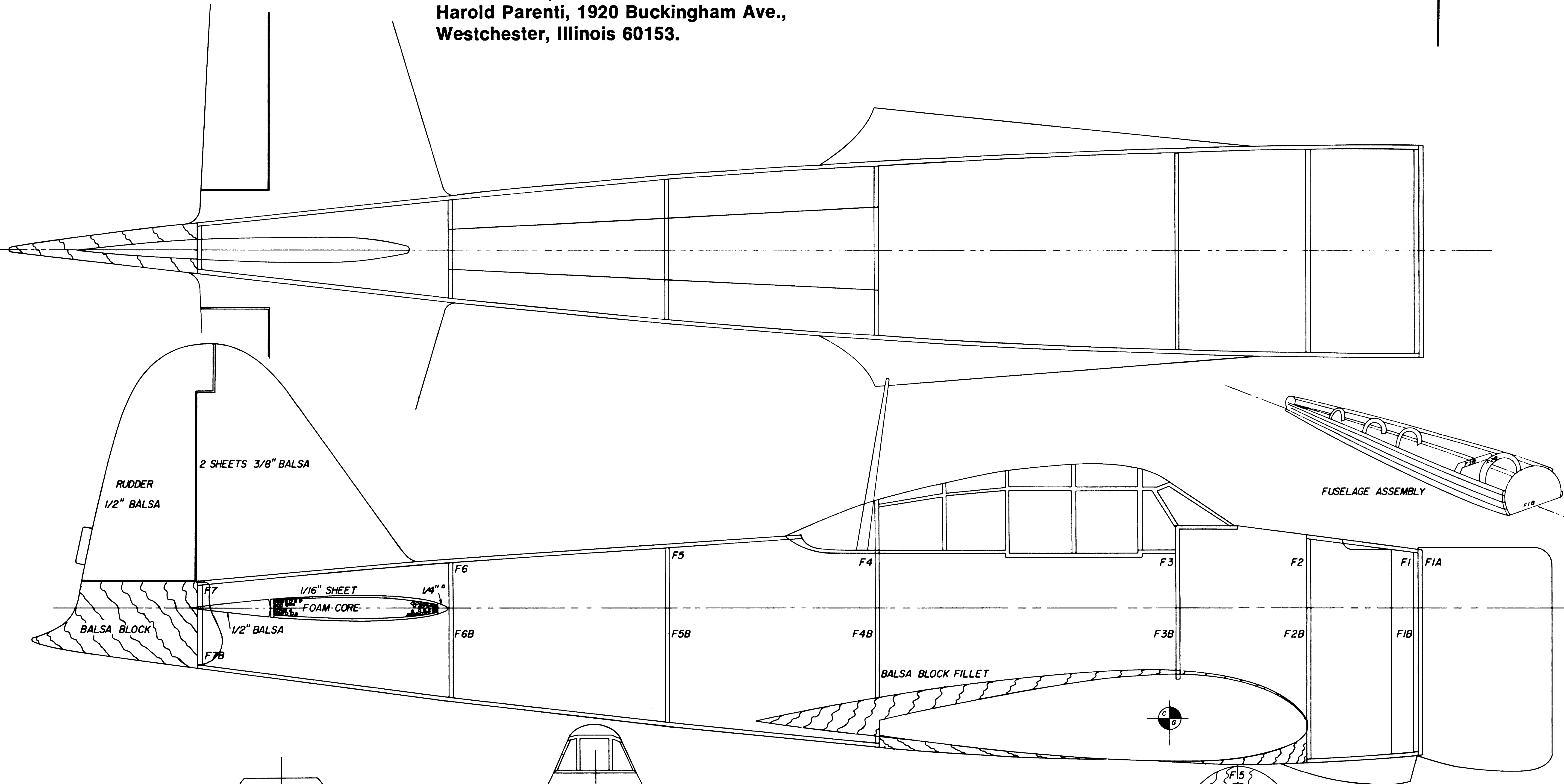

FUSELAGE ASSEMBLY

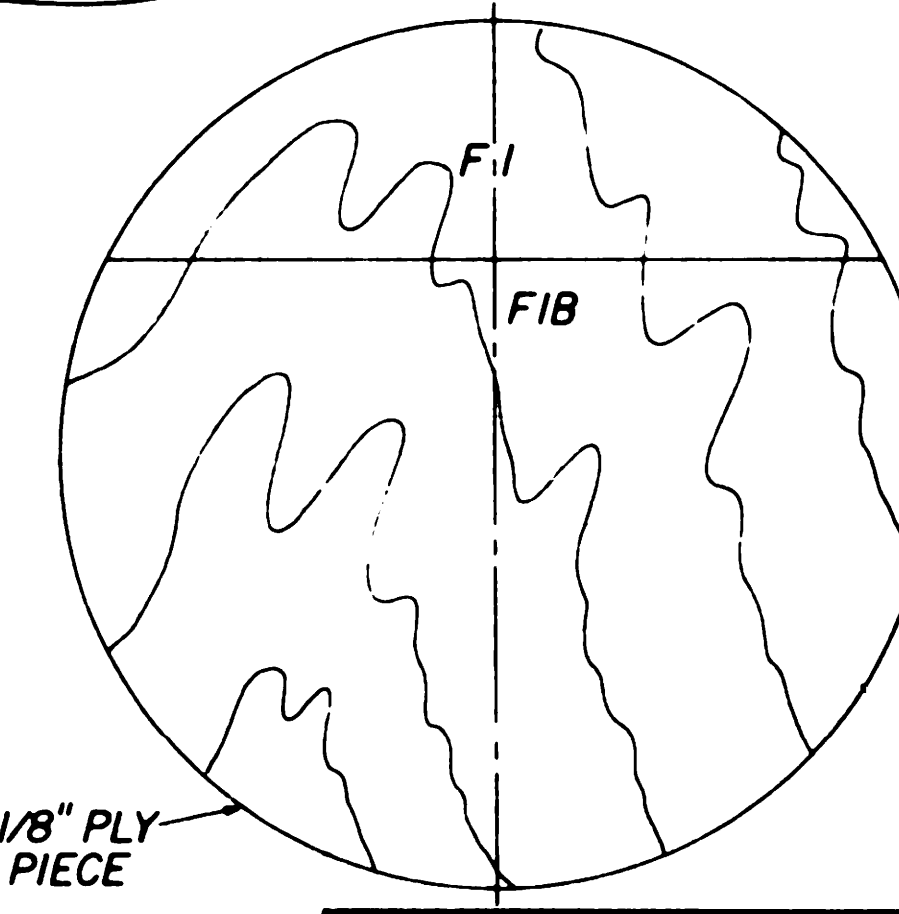
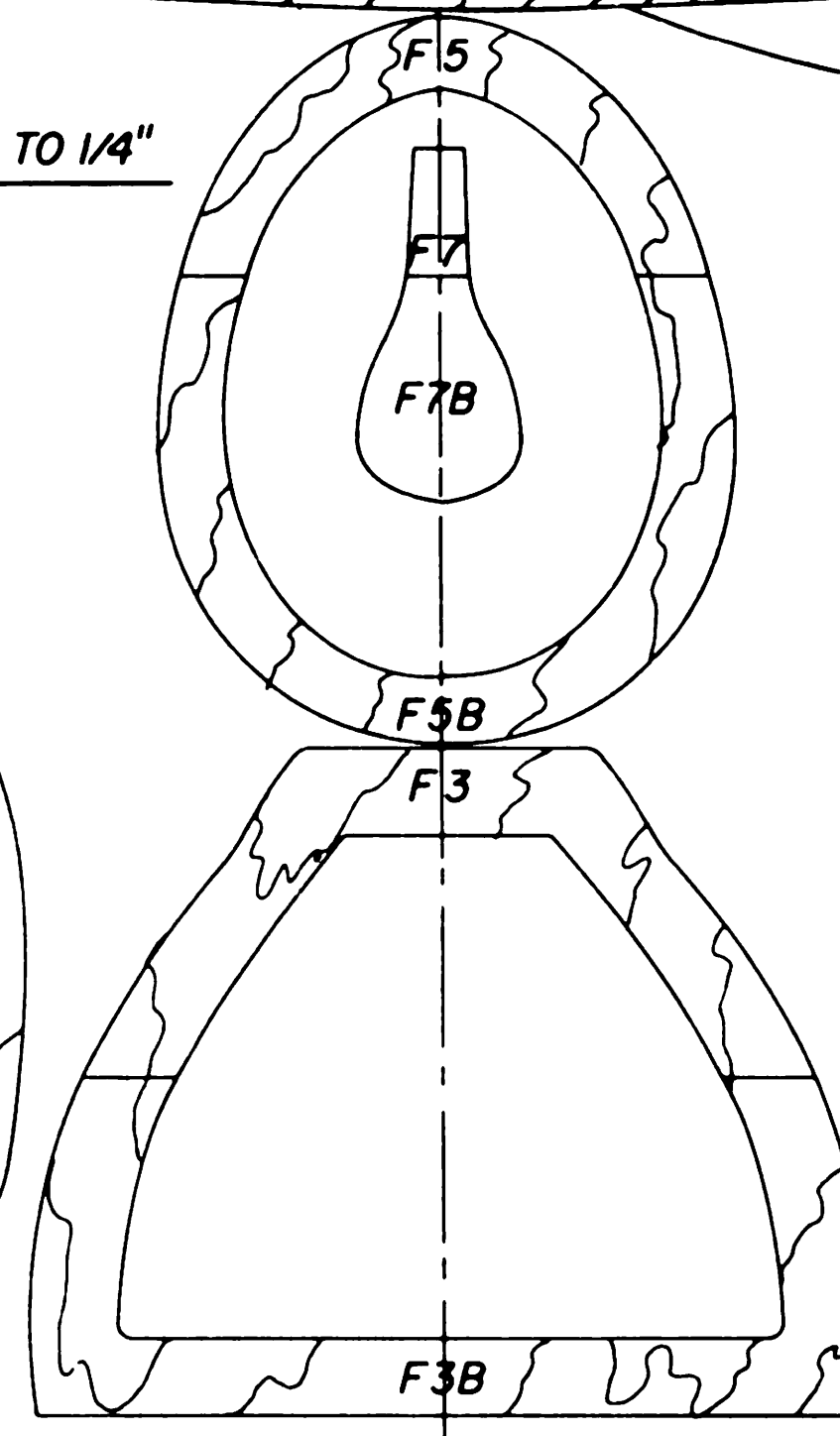
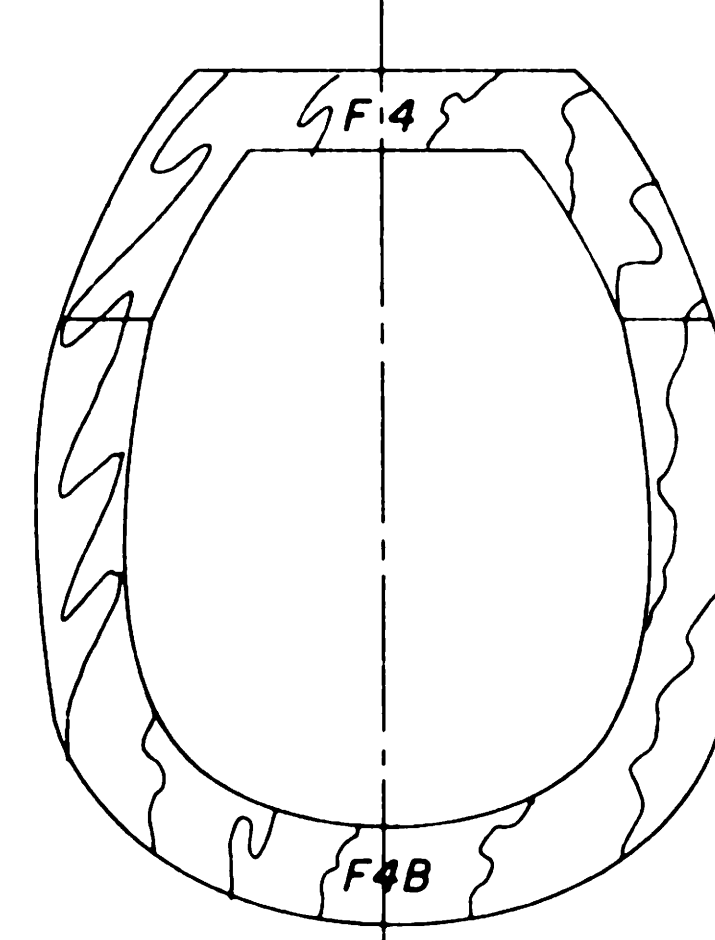
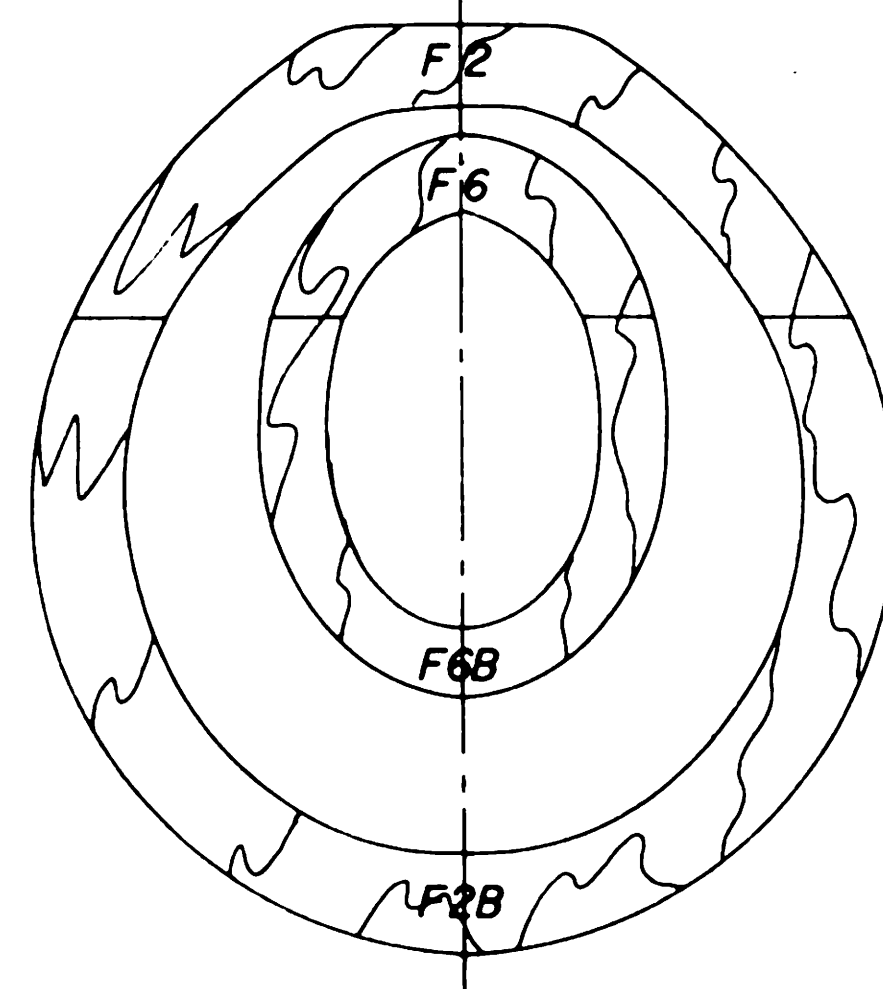
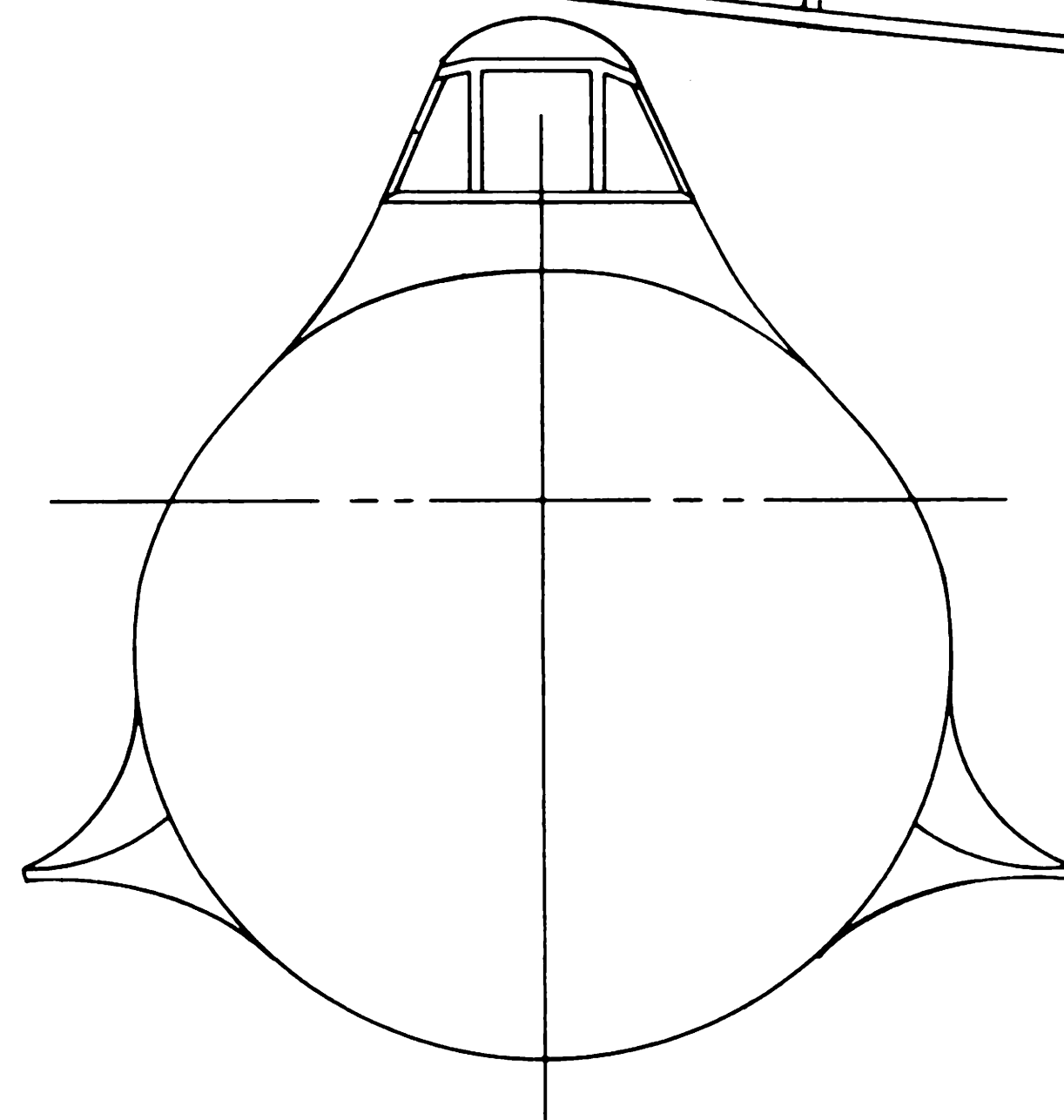
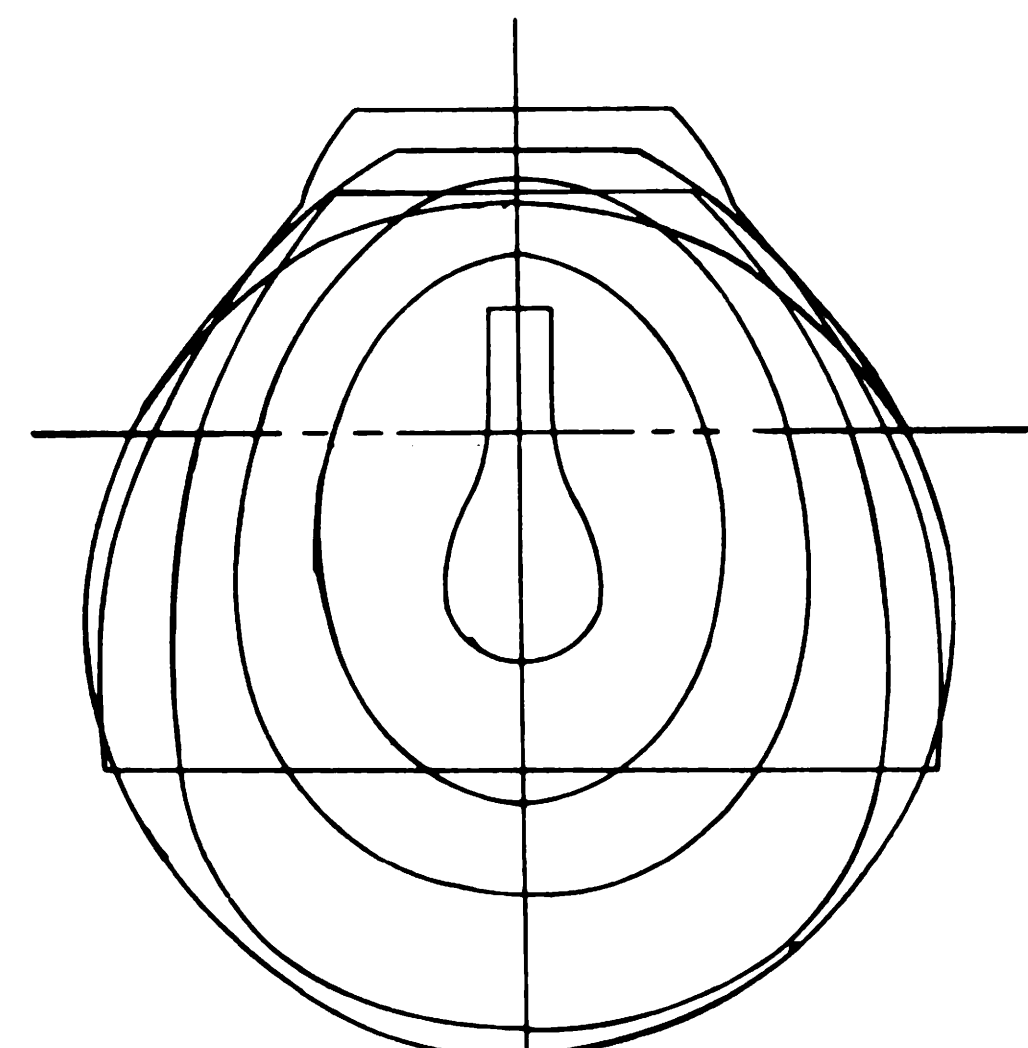

ENTIRE FUSELAGE PLANKED WITH 3/16" X 5/8" SHEET TAPERED TO 1/4"

OUTLINES FOR 7 BULKHEADS 3/32" 5 PLY PLYWOOD
 ADD 1/2" INNER OUTLINE TO BULKHEADS 2 THRU 7
 CUT ALL BULKHEADS ON HORIZONTAL C/L EXCEPT F1A
 ASSEMBLE FUSELAGE OVER TOP VIEW USING B BULKHEADS PLACED ON CENTER LINES
 PLANK COMPLETELY STARTING AT PLAN SURFACE AND ALTERNATE SIDES

F1A 1/8" PLY ONE PIECE

SCALE 11/16" = 1 FT SPAN 90"

ZERO-SEN MODEL 21
 MITSUBISHI A6M2

DESIGNED AND DRAWN BY HAL PARENTI

125

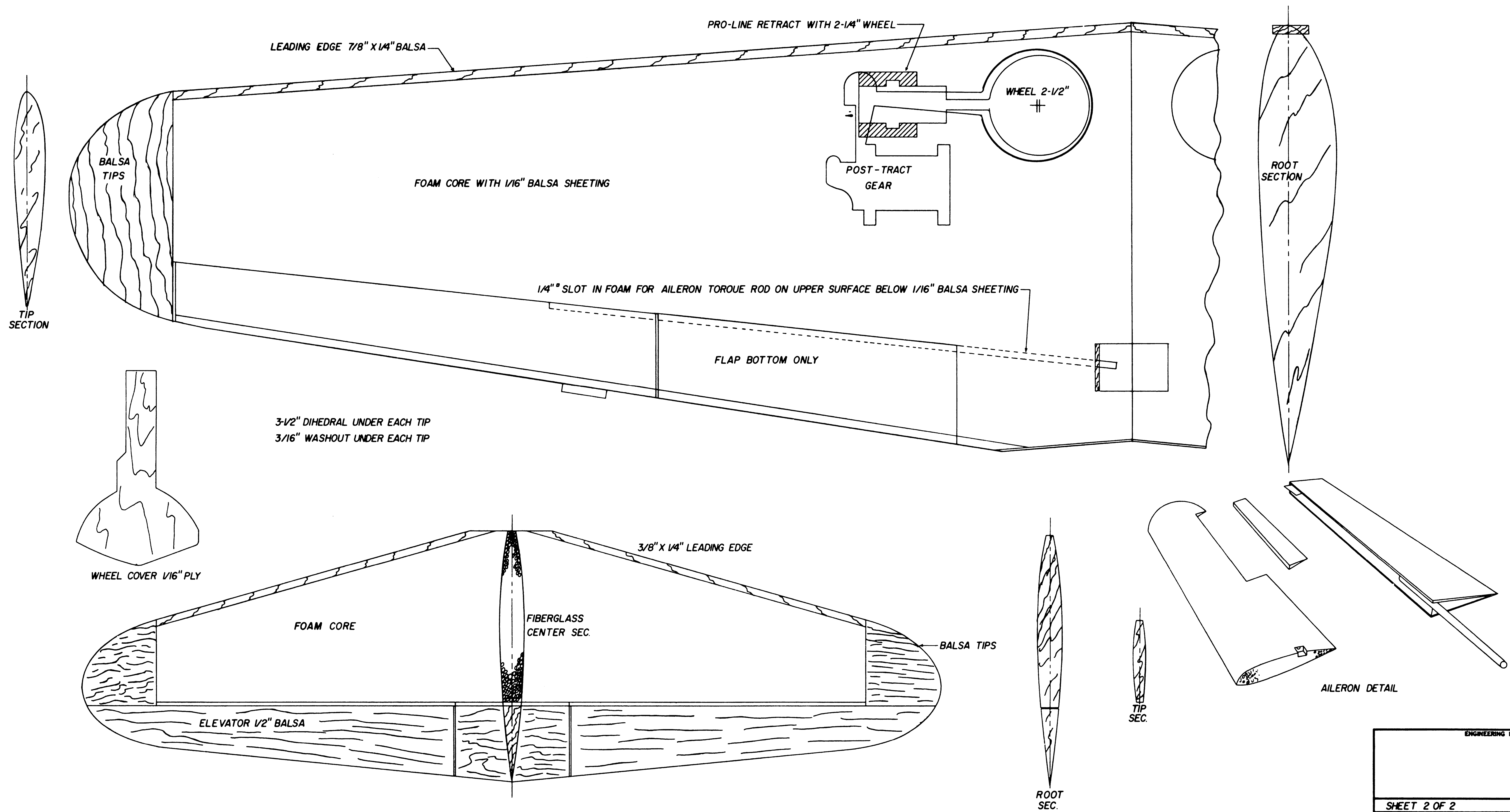

ENGINEERING NOTES	
SHEET 2 OF 2	
ZERO - SEN	
DESIGNED AND DRAWN BY HAL PARENTI	
SCALE 125	PRINTED IN U.S.A.