

TODAS LAS COSTILLAS EN Balsa DE 1,5 mm

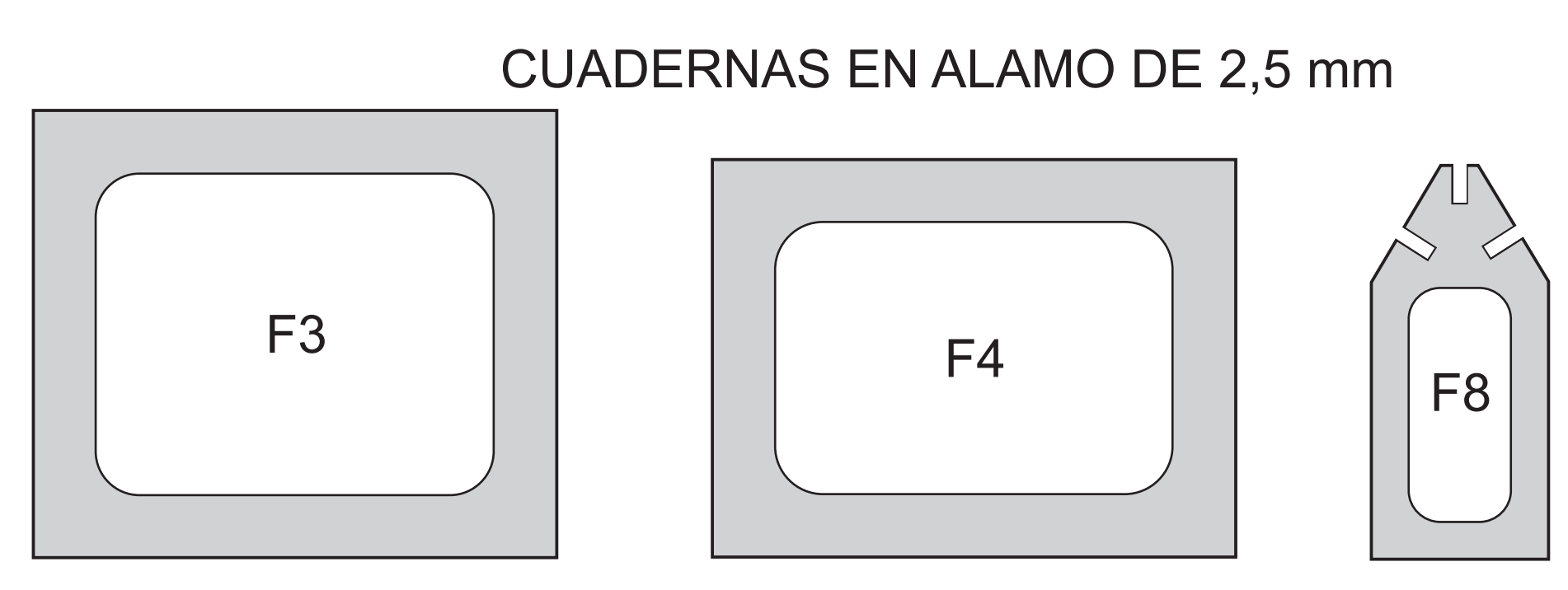

\* LOS LATERALES TAMBIEN SE PUEDEN CONSTRUIR CON Balsa DE 2,0 mm SIN CALAR

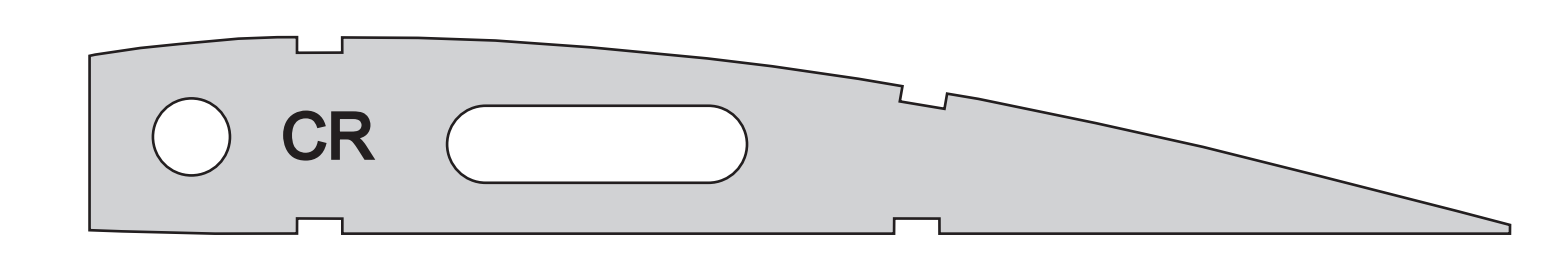
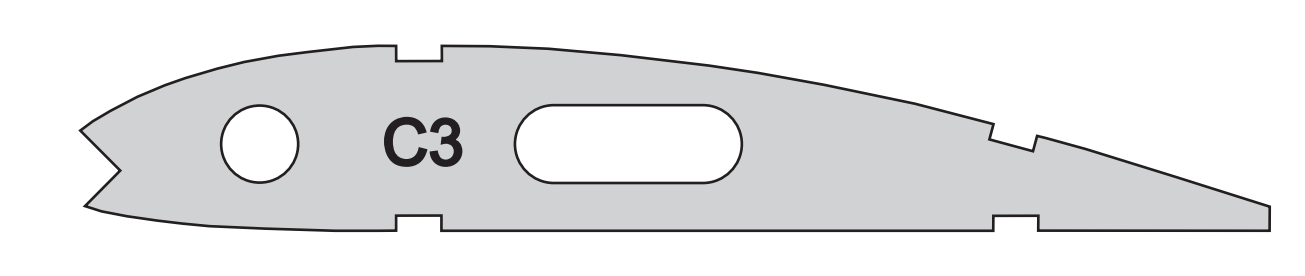
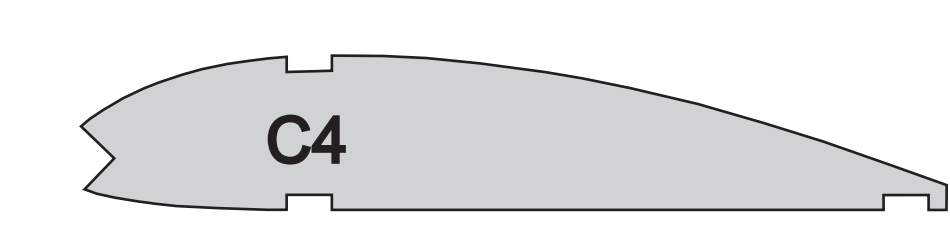
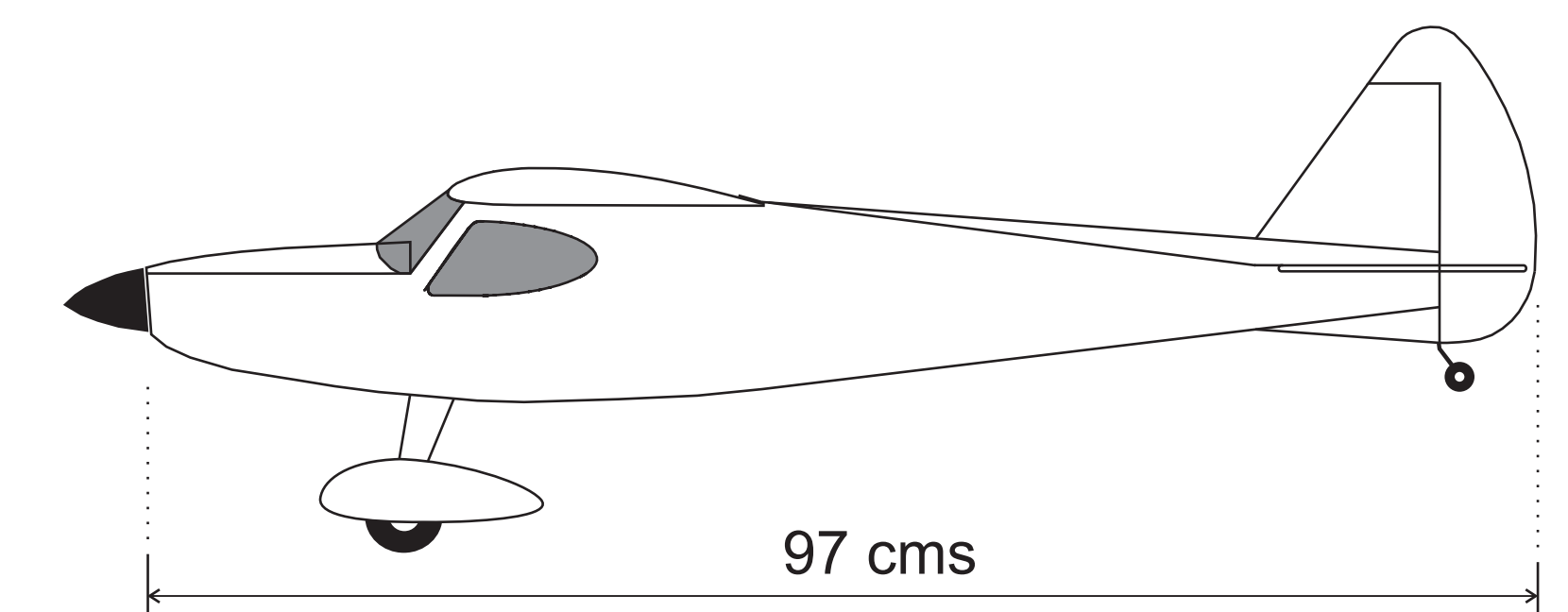
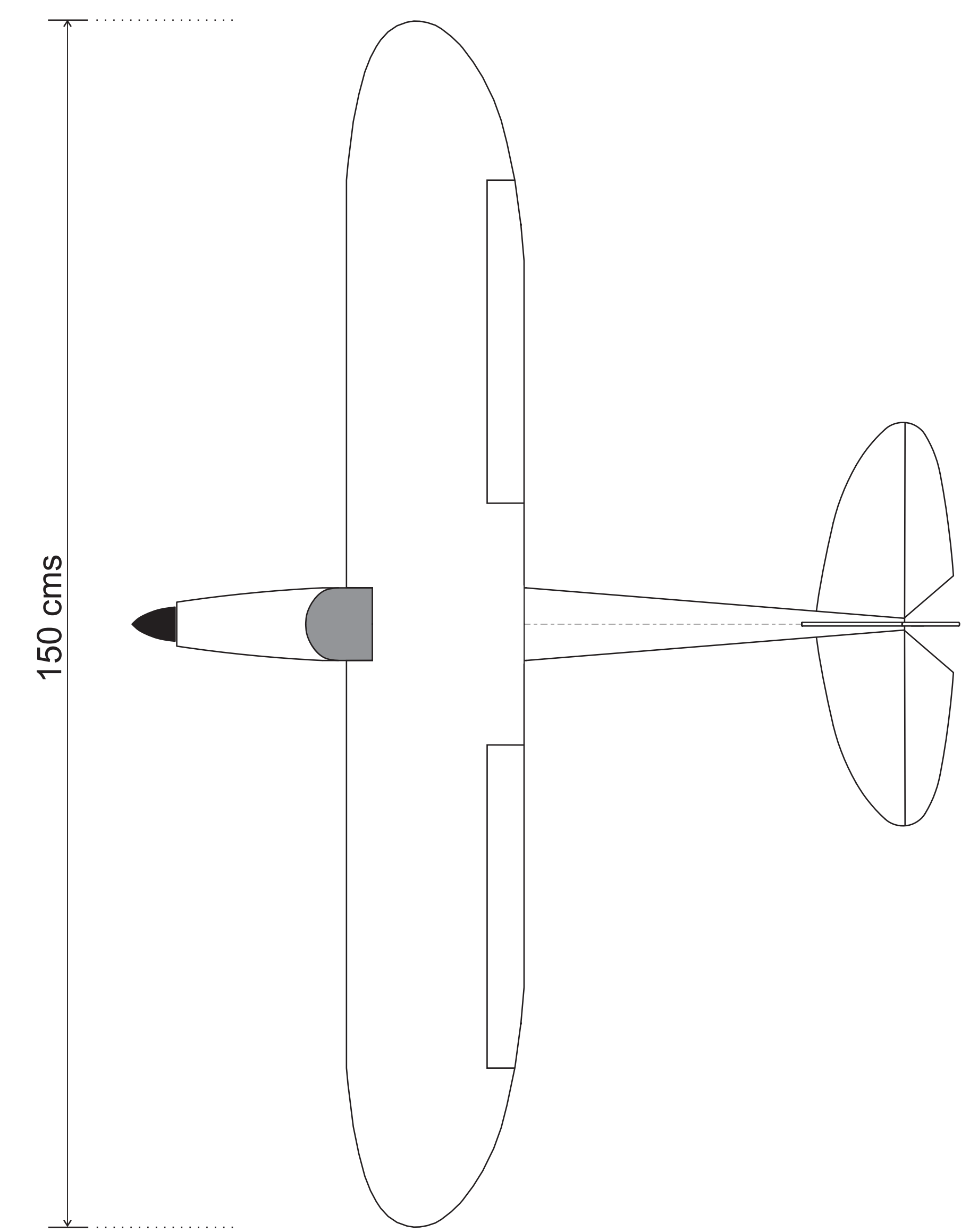
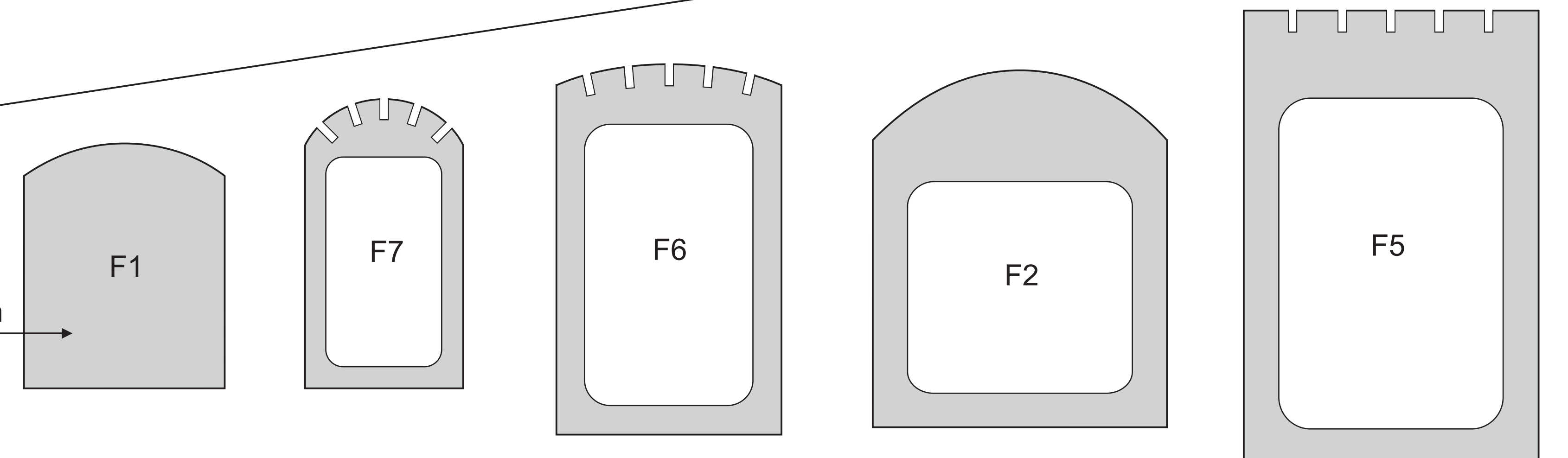

DIEDRO: 15 mm por lado  
 SUP. ALAR: 31.00 dm<sup>2</sup>  
 PESO (máximo): 1.500 Grs.  
 CANALES: 4  
 SERVOs: 4 (mini de 2,5 kg/cm @ 6V)  
 MOTOR ELECTRICo: 250 / 350 W.  
 OPCIONALMENTE SE PUEDE INSTALAR UN MOTOR GLOW .28 / 40 MODIFICANDO LA POSICION DE LA F1



DISEÑO Y DIBUJO  
 JOSE RAUL YUNES - 10/2015