

ORIGINAL DESIGN HAD BULKHEADS MADE IN 2 SETS, UPPER (T) & BOTTOM (B). THESE SETS WERE THEN GLUED TO THE CROSS BRACES ABOVE & BELOW. SUGGEST RELOCATING THE BRACES TO BEHIND THE SHOWN BULKHEAD LOCATIONS & MAKING BULKHEADS IN ONE PIECE EACH WITH THE GRAIN VERTICAL & ADDING THEM AFTER THE CRUTCH IS THOROUGHLY DRY.

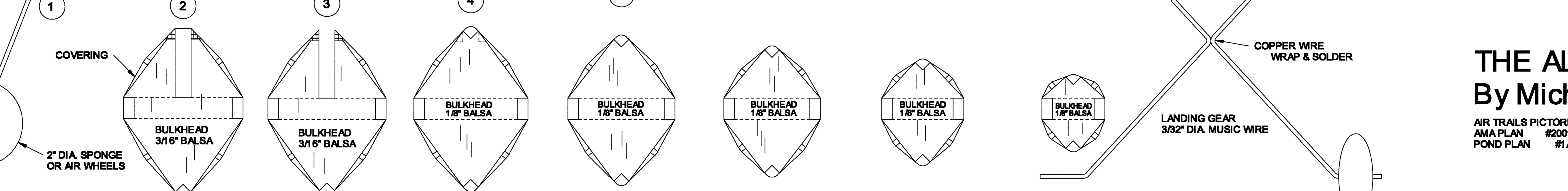
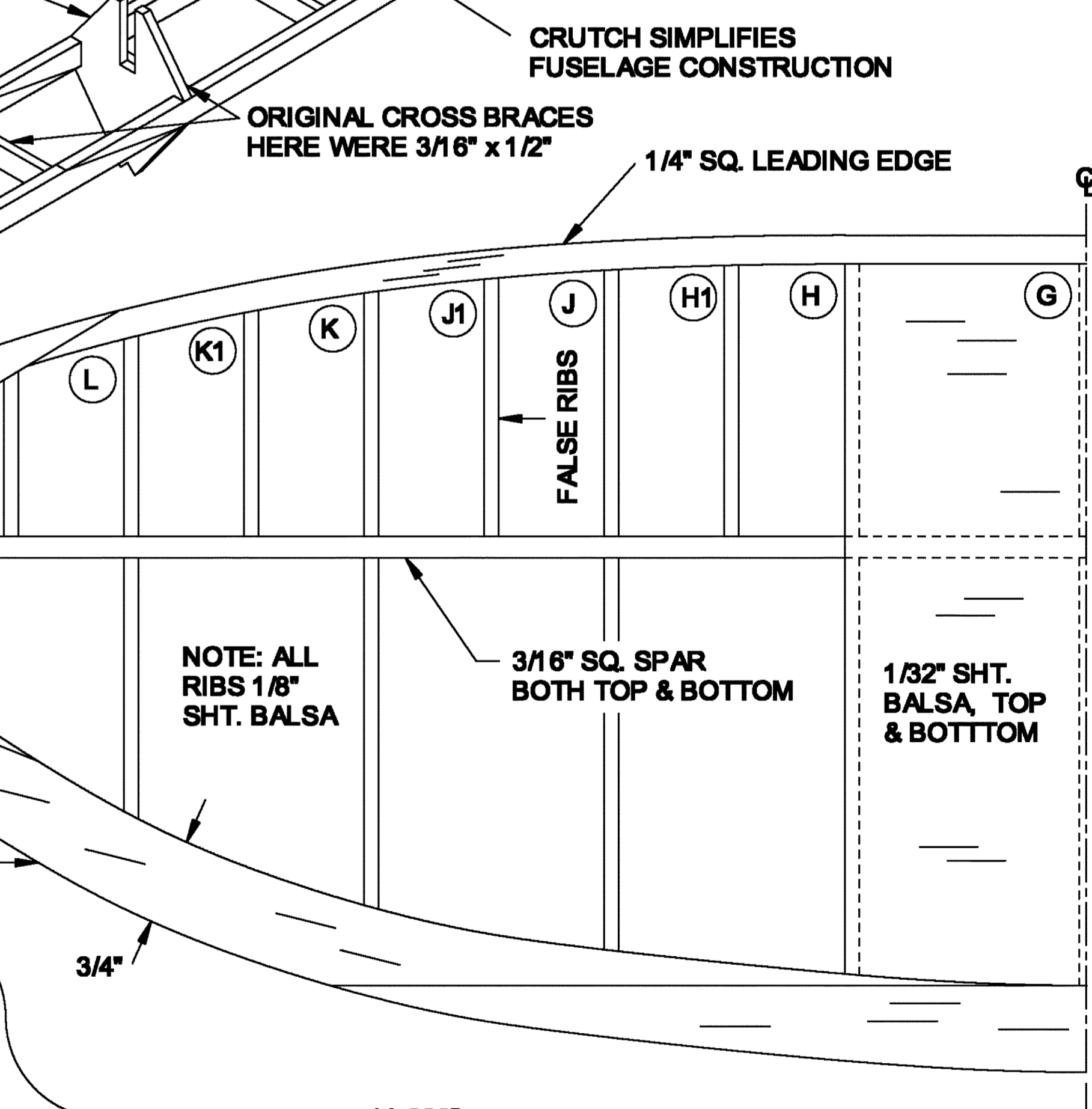
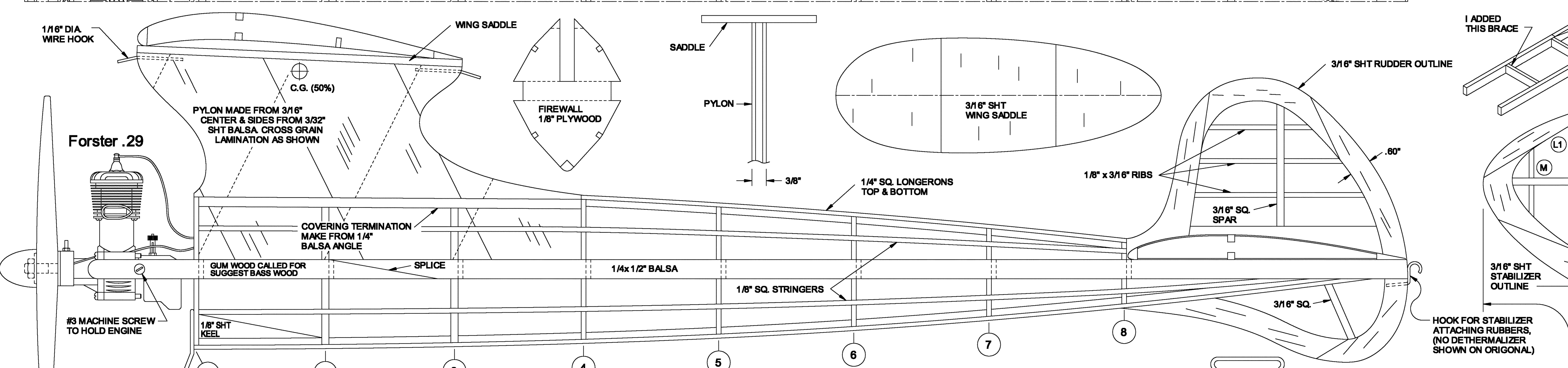
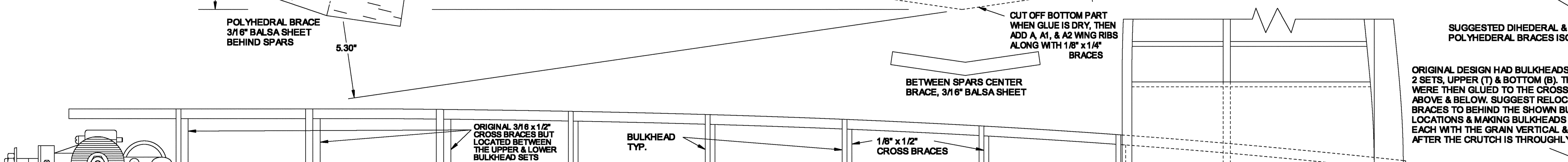

THE ALERT
By Michael Latorre

AIR TRAILS PICTORIAL
AMA PLAN #20013
POND PLAN #1A5

DECEMBER, 1942