

W-1 RIBS ARE FLAT-BOTTOMED CUT SPAR SLOTS AFTER RIBS ARE ASSEMBLED AROUND WING BOX
FRONT SPARS 3/32 SQ.
REAR SPARS 1/16 X 3/32

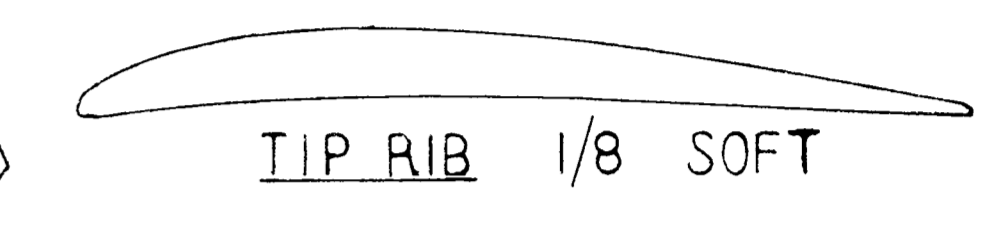
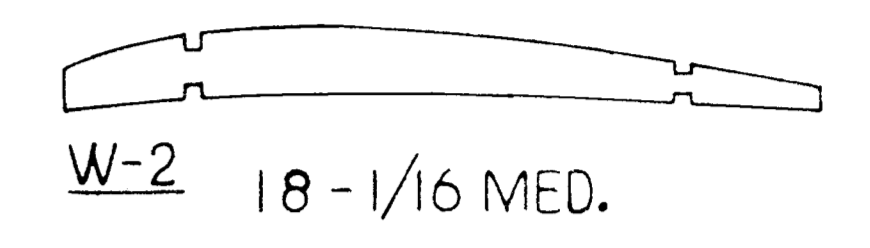
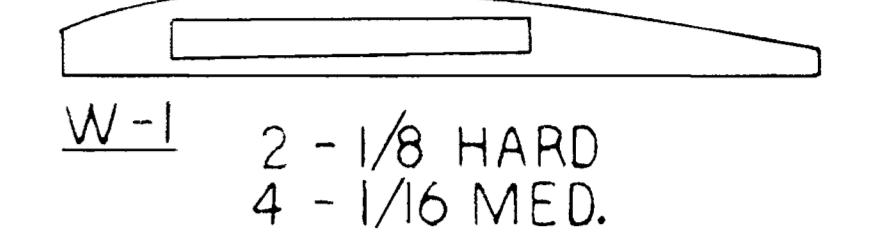

SCALLOPS SANDED INTO T.E. AFTER WING CONSTRUCTION

RIGGING "WIRES" ARE SEWN THROUGH THESE POINTS IN SPARS TO THE FUSELAGE RIGGING POST AND LOOP ON L.G. PART "D"

LANDING GEAR DETAILS
BEND FROM 1/16 AND 1/32 MUSIC WIRE

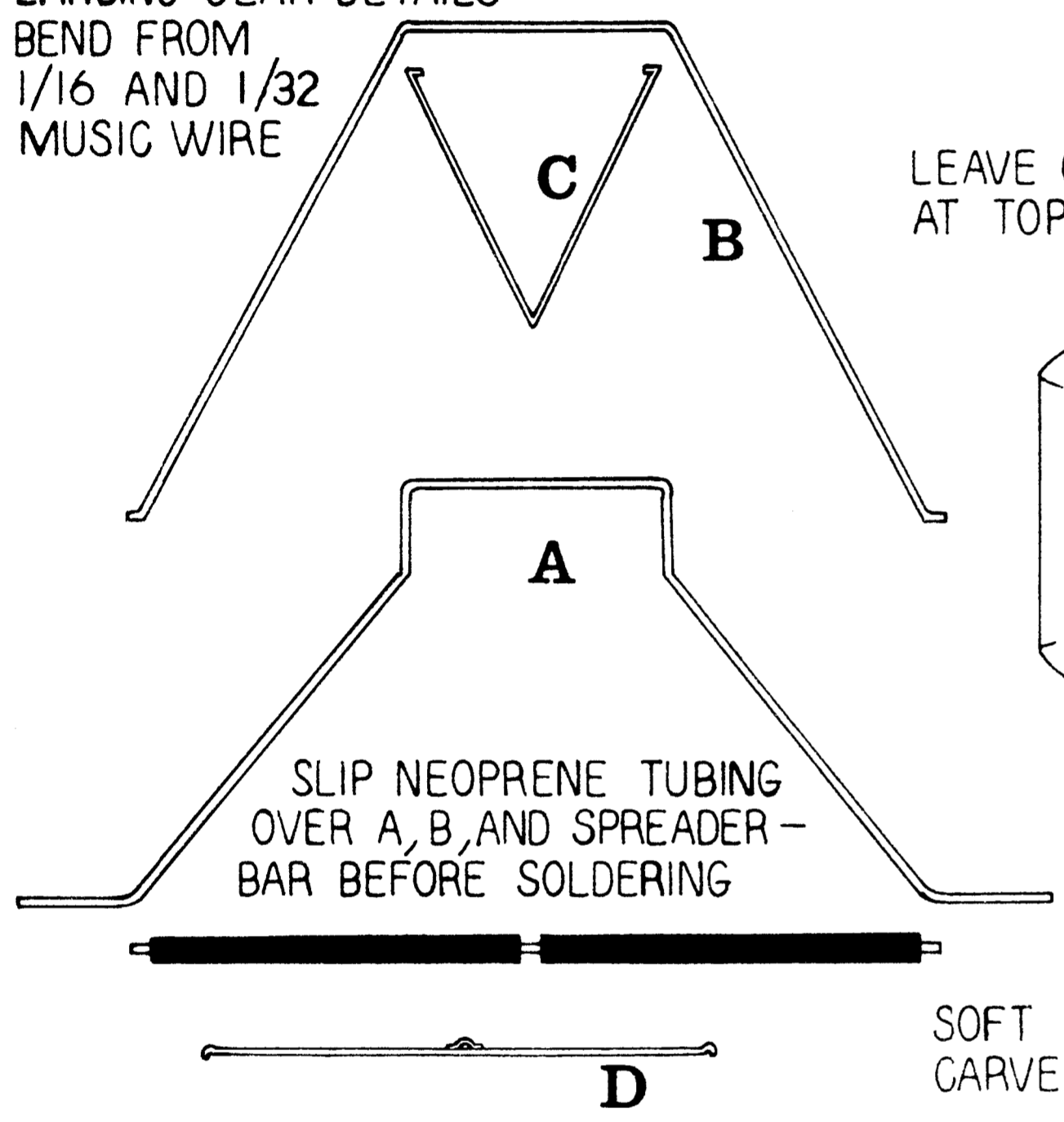

LEAVE COWL OPEN AT TOP FOR ENGINE ACCESS

NEOPRENE TUBING COCKPIT PADDING

TOP VIEW

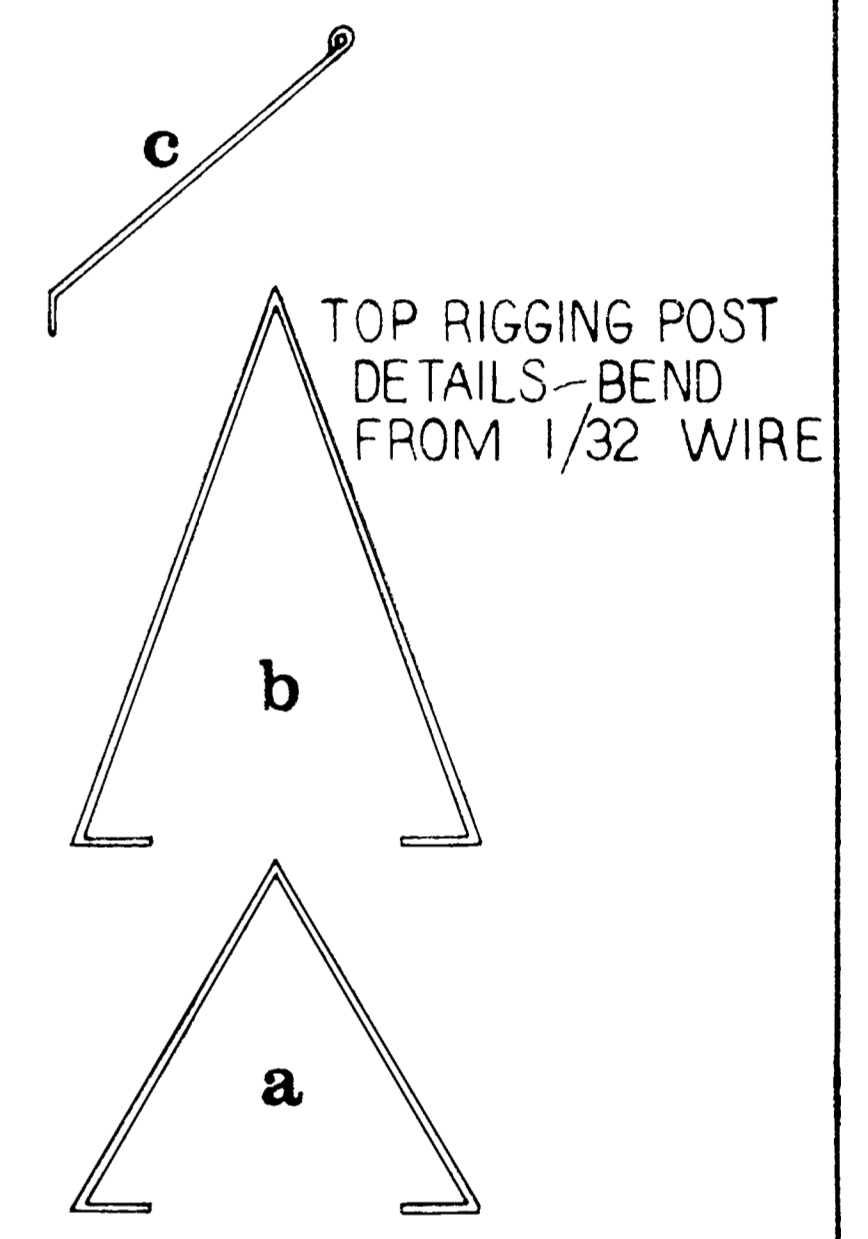
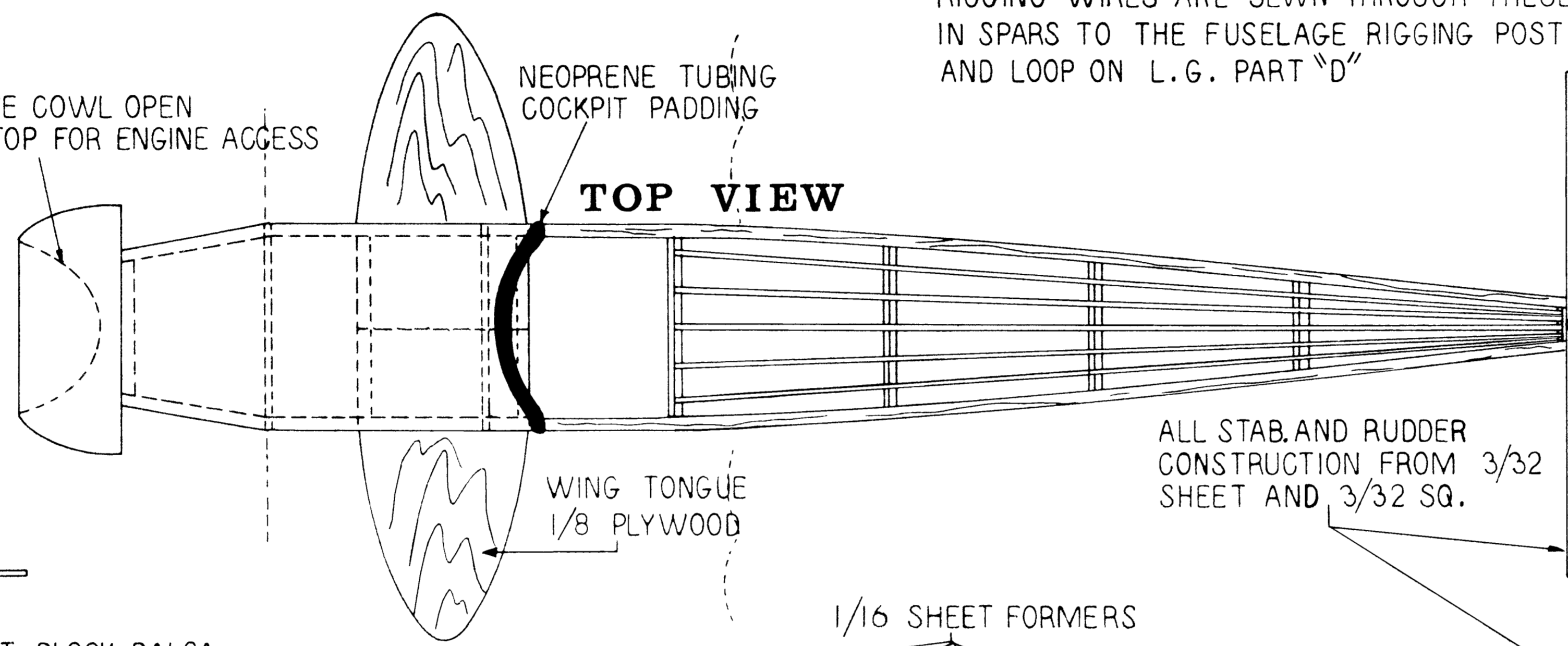

SOFT BLOCK Balsa CARVE TO ROUNDED SECTION

1/16 SHEET FORMERS

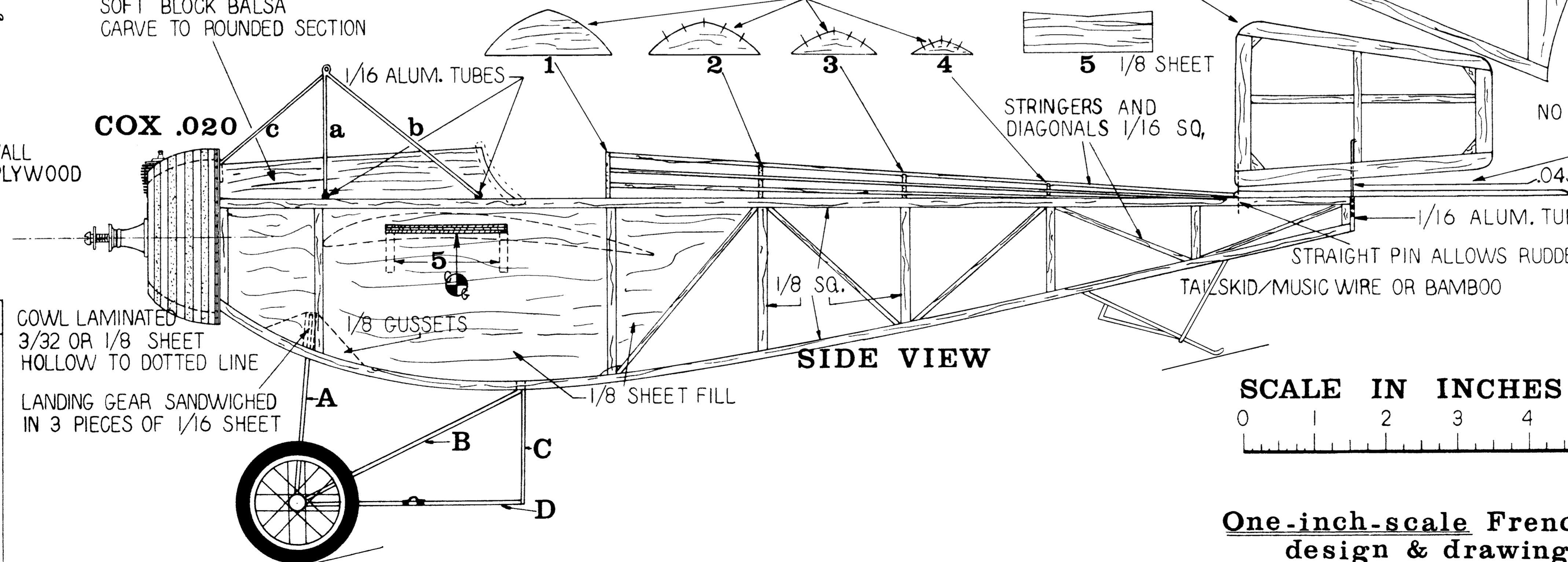

SIDE VIEW

SCALE IN INCHES

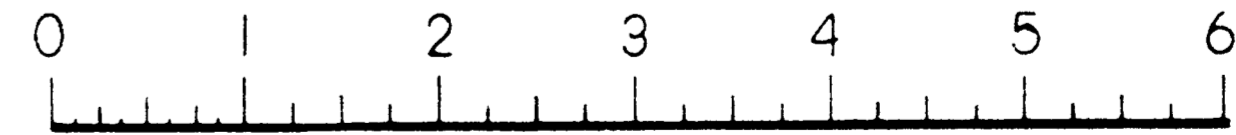

One-inch-scale French CAUDRON design & drawing: Harry H. English

ALL MATERIALS Balsa EXCEPT AS NOTED

FRENCH CAUDRON—CIRCA 1910 OR 1911

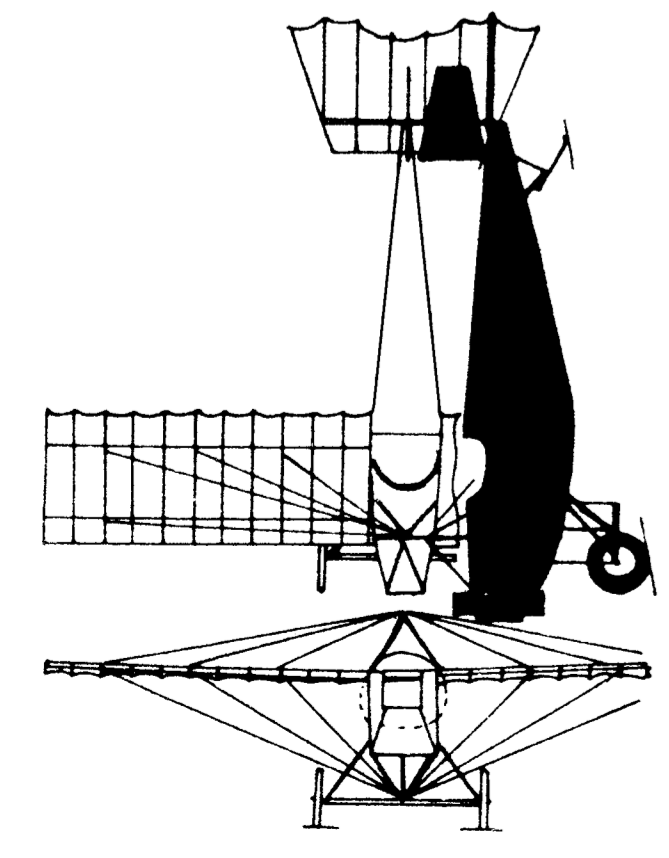

THESE 3 VIEWS FROM A 1934 ISSUE OF MODEL AIRPLANE NEWS

