

CONTROL SURFACE TRAVEL
 AILERONS — 3/16" UP AND 3/16" DOWN
 ELEVATORS — 3/16" UP AND 3/16" DOWN

ADDITIONAL INFORMATION
 TANK SIZE — AS AN ALTERNATE, A 2 OUNCE "PYLON" ROUND TANK (NO. R-2) EASILY FITS IN THE TANK COMPARTMENT WITH NO MODIFICATIONS
 SPINNER — 1-1/4" SPINNERS CAN BE USED WITH EXISTING SPINNER RING (SLIGHT SANDING NECESSARY TO REDUCE NOSE DIAMETER AT FRONT END).
 RADIO SYSTEM — THE RADIO COMPONENTS SHOWN ARE COX/SANWA 2-CHANNEL (NO. 8022) WITH NO. 800030 BATTERY PACK (250 MAH).

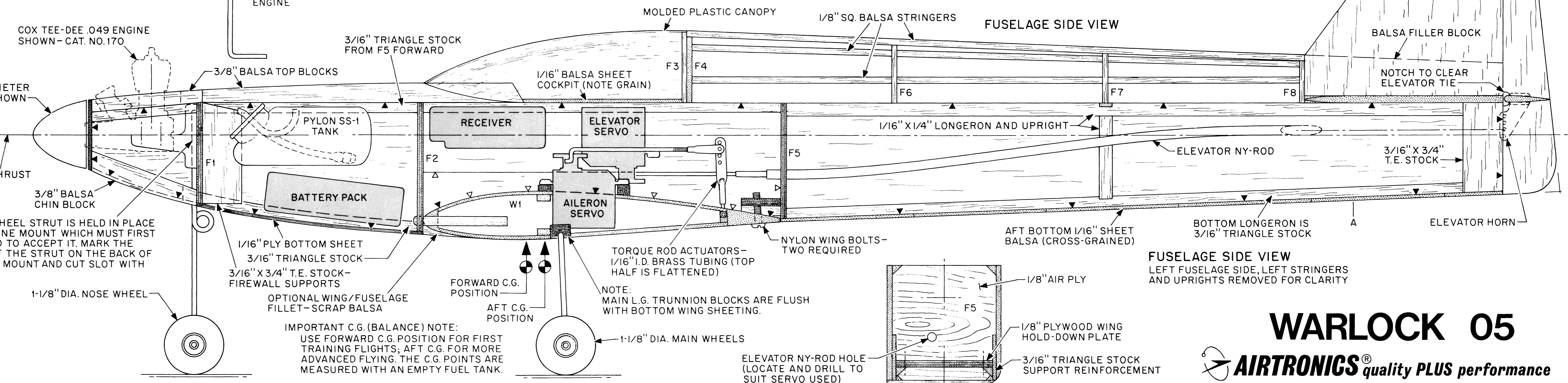
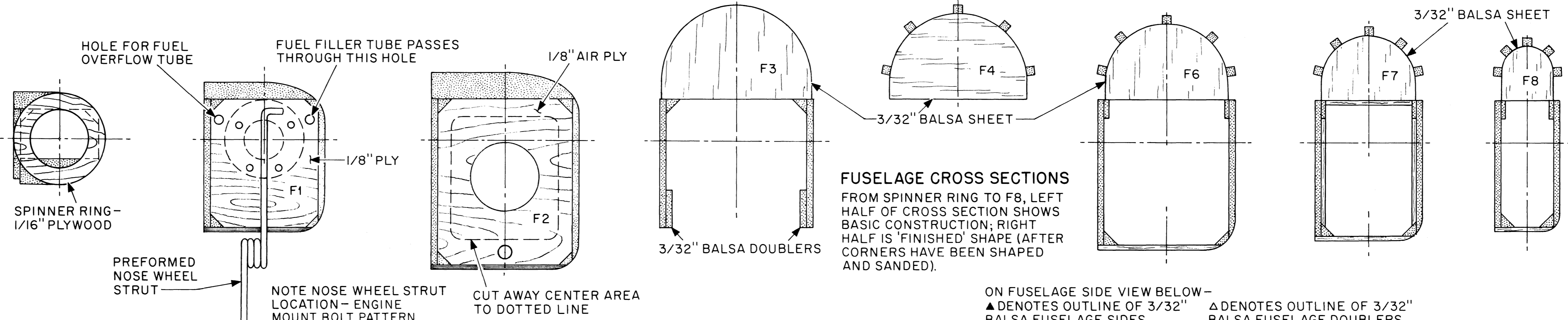
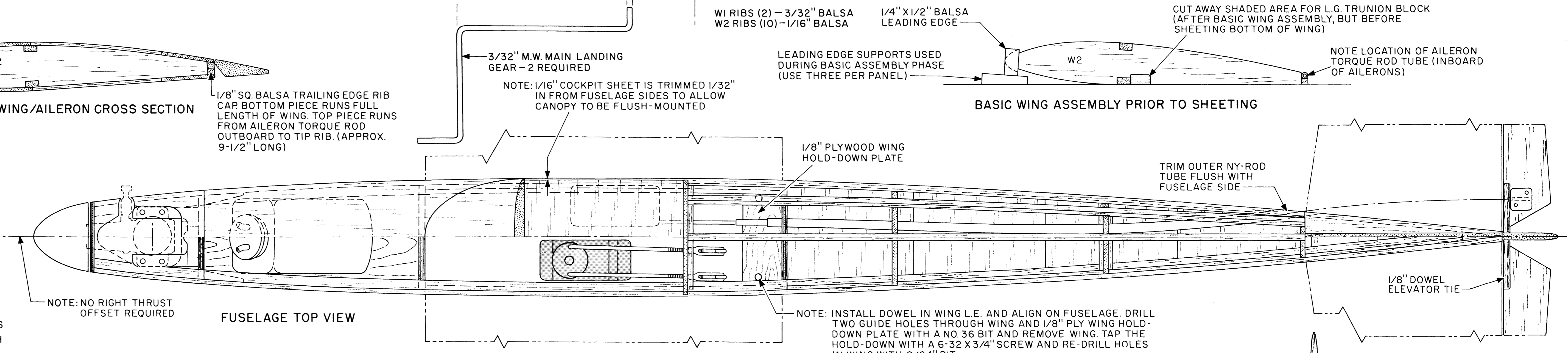
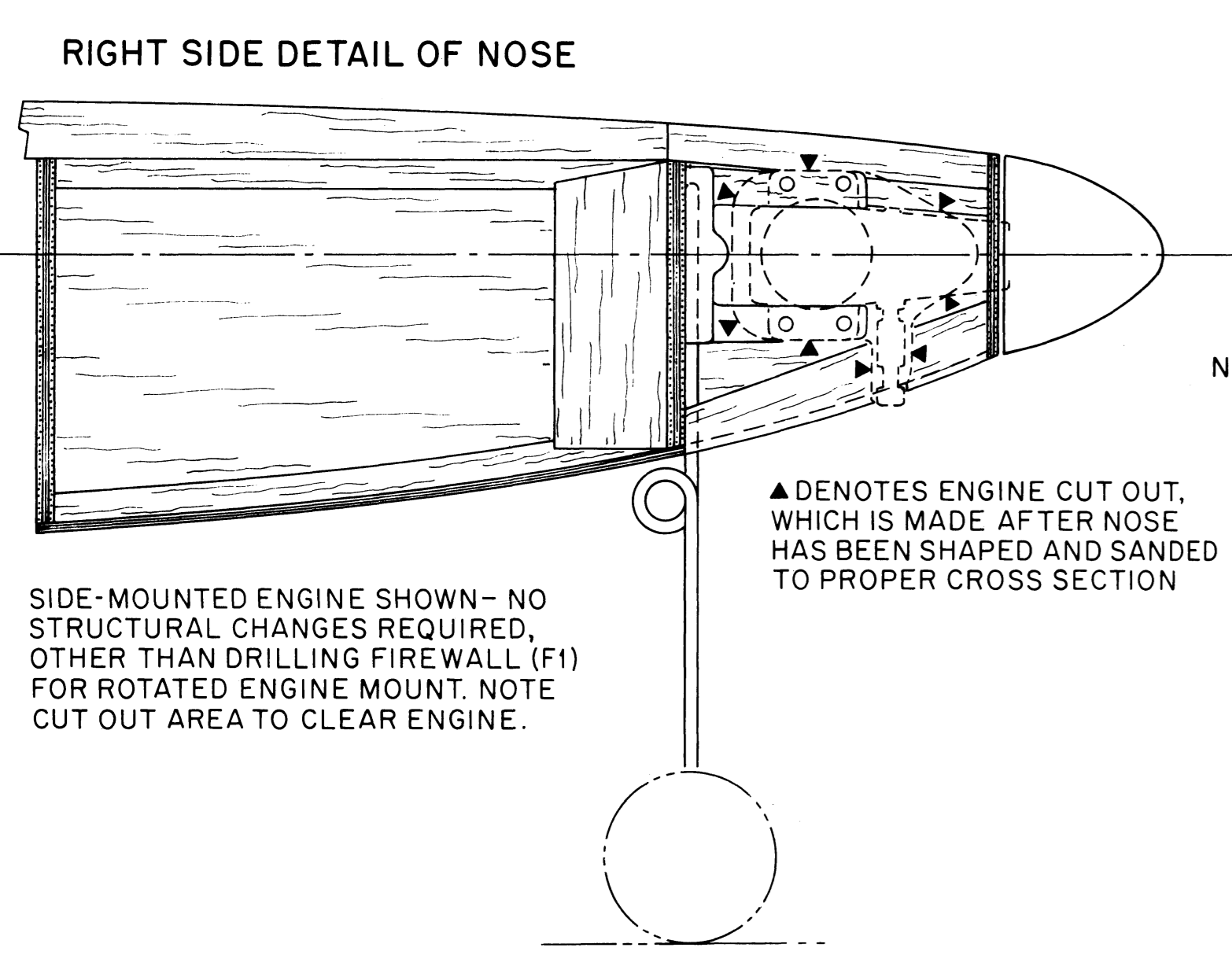
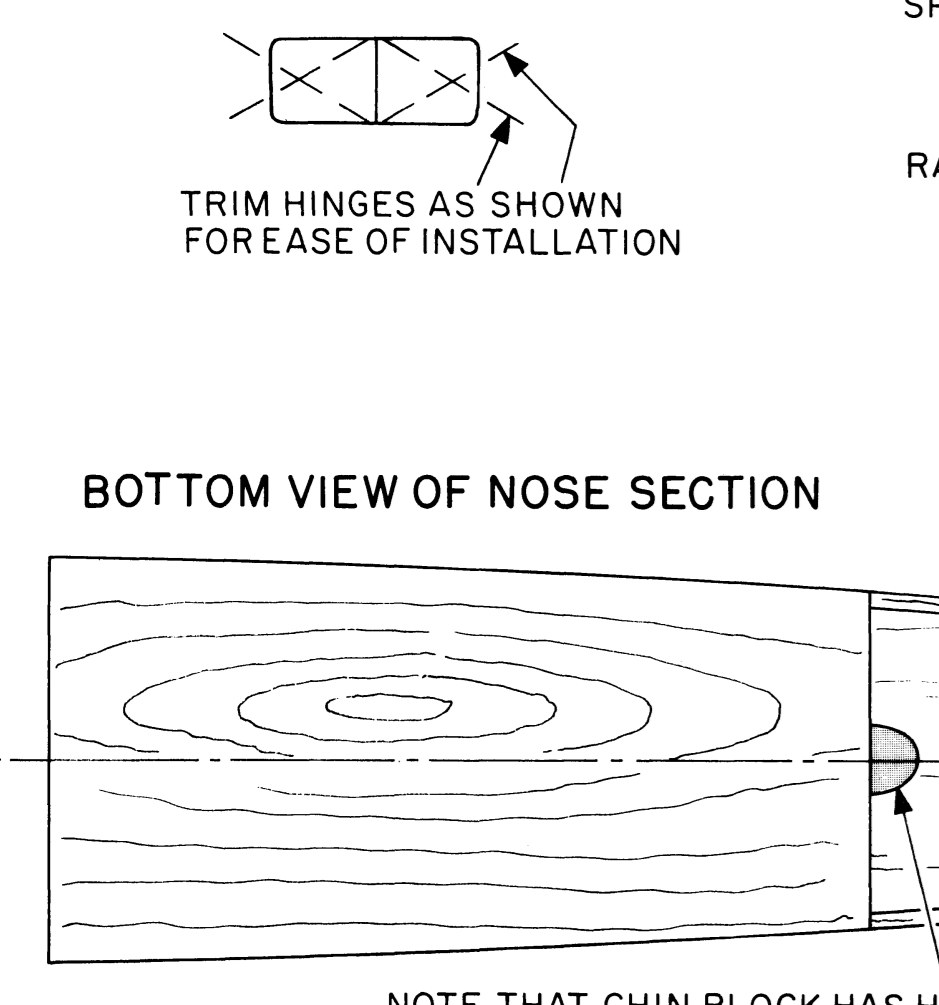

WARLOCK 05

AIRTRONICS quality PLUS performance
 © COX HOBBIES INC. SHEET 1 OF 1 SHEETS PLAN NO. 93031700