

UNLESS NOTED OTHERWISE ALL WOOD IS CONTEST GRADE BALSA

ENGINE WAS TO BE RAISED FOR TAKEOFF.

USE 5 DIA PLASTIC PROP WITH LARGE THRUST BUTTON. SPINNER OPTIONAL.

RADIATOR TUBING CAN BE SIMULATED WITH BROOM STRAWS PAINTED BRONZE OR PAINTED ON AND OUTLINED WITH STRIPING TAPE.

ITALIAN SCHNEIDER ENTRIES WERE PAINTED A DEEP RED

JRW 2-79

MAIN FUSLAGE CONSTRUCTED FROM 1/16 SQ HARD BALSA

STRINGERS(5) 1/32 SQ. BAMBOO

CARVE HEAD REST FROM SOFT BALSAL

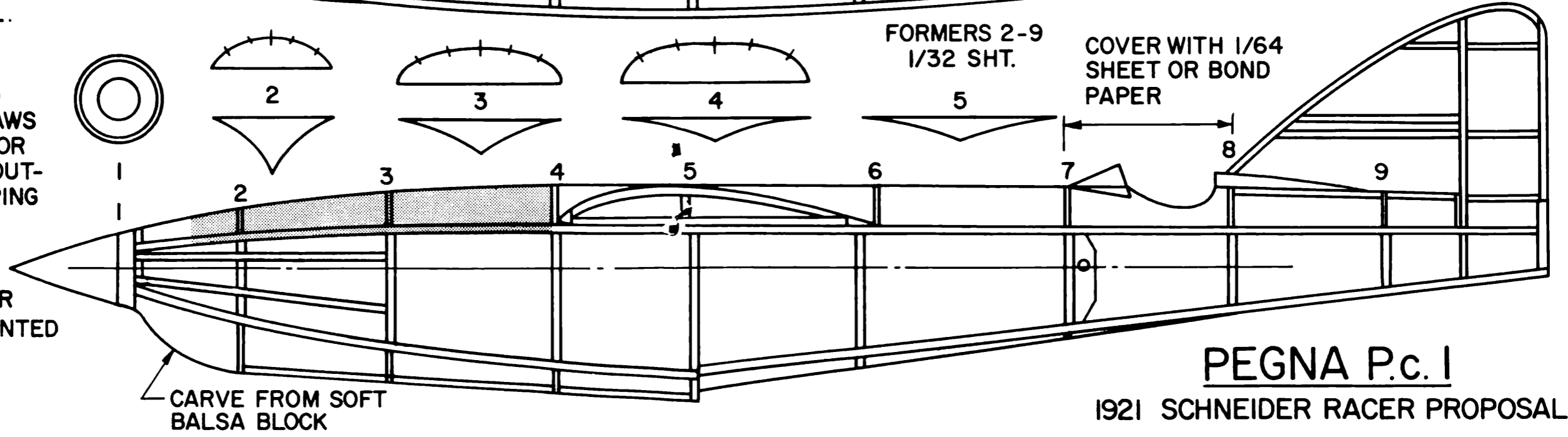

PEGNA P.c. I

1921 SCHNEIDER RACER PROPOSAL