

NOTES:

- * All parts made from 6mm Depron or BlueCore foam unless otherwise indicated
- * Sand all wing and empennage leading edges round and apply a piece of 3M Satin tape around the leading edge to add smoothness and durability
- * Cut 45 deg bevels on the leading edge of all control surfaces and hinge with 3M Satin tape
- * Strengthen the wing leading edges and the bottom of the fuselage with packing tape or light fiberglass to improve durability.
- * Recommended control deflections (all dimensions measured at root trailing edge):
 - Elevator: +/- 1.0" (40% exponential)
 - Ailerons: +/- 0.75" (40% exponential)
 - Rudder: +/- 1.25" (25% exponential)

RECOMMENDED POWER SETUPS:

- 1) Grayson 2212-06 motor, 2100 mAh 11.1V lipo battery, APC 6x4E prop
- 2) Littlescreamers Super Park Jet motor, 1320 or 2100 mAh 11.1V lipo battery, APC 7x5E prop
- 3) Littlescreamers Park Jet motor, 1320 mAh 11.1V lipo battery, APC 6x4E prop

Typical fuselage cross section

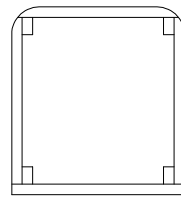

Cut hatch to fit battery, and attach with Scotch tape on all sides to make waterproof seal

0.22" dia x 28.0" carbon tube main spar

1/32" ply auxiliary spars

Thunder Power
2100 mAh 11.1V

7.69"

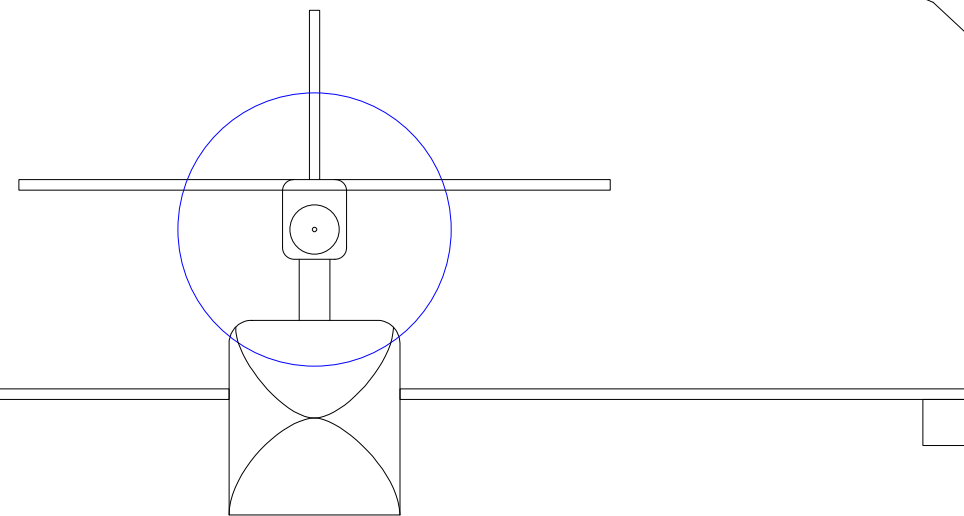
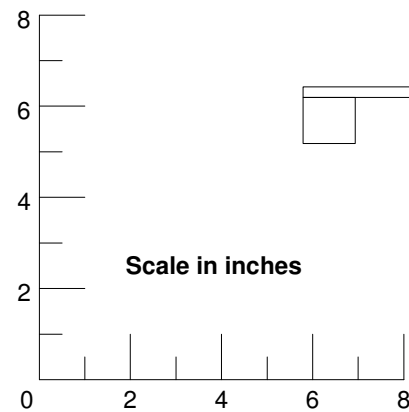

For 6" diameter props, mount motor on bottom of firewall (shown here). For 7" diameter props, mount motor on top.

-2 degrees incidence for thrust line and horiz tail

Internal channel for running motor and elevator servo wires

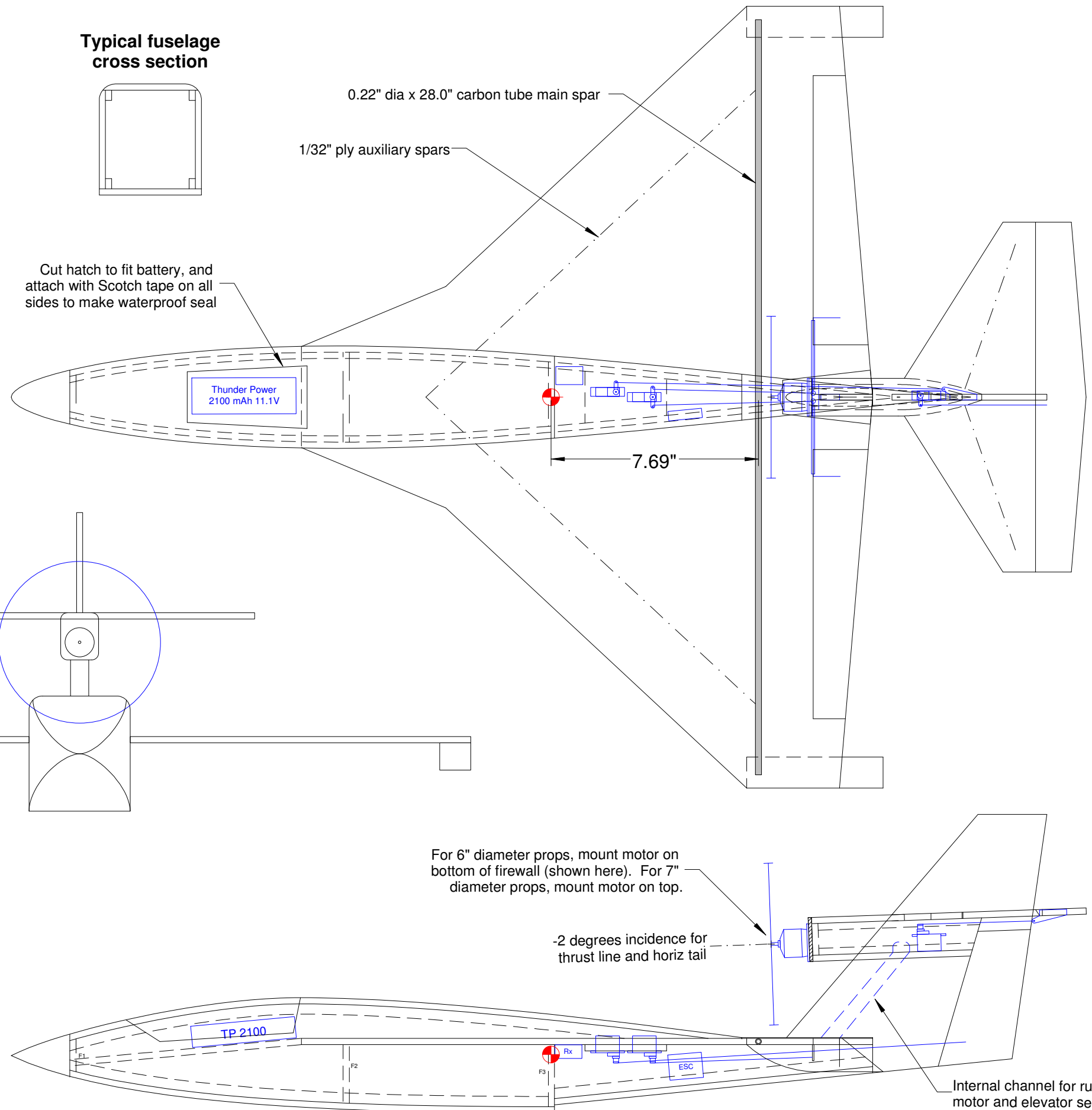

Polaris

Span: 29.0"
Wing area: 343 sq in
Weight: 18 - 22 oz RTF
Wing loading: 8.4 oz/sq ft

Designed and drawn by Steve Shumate
Copyright © 2008 All Rights Reserved

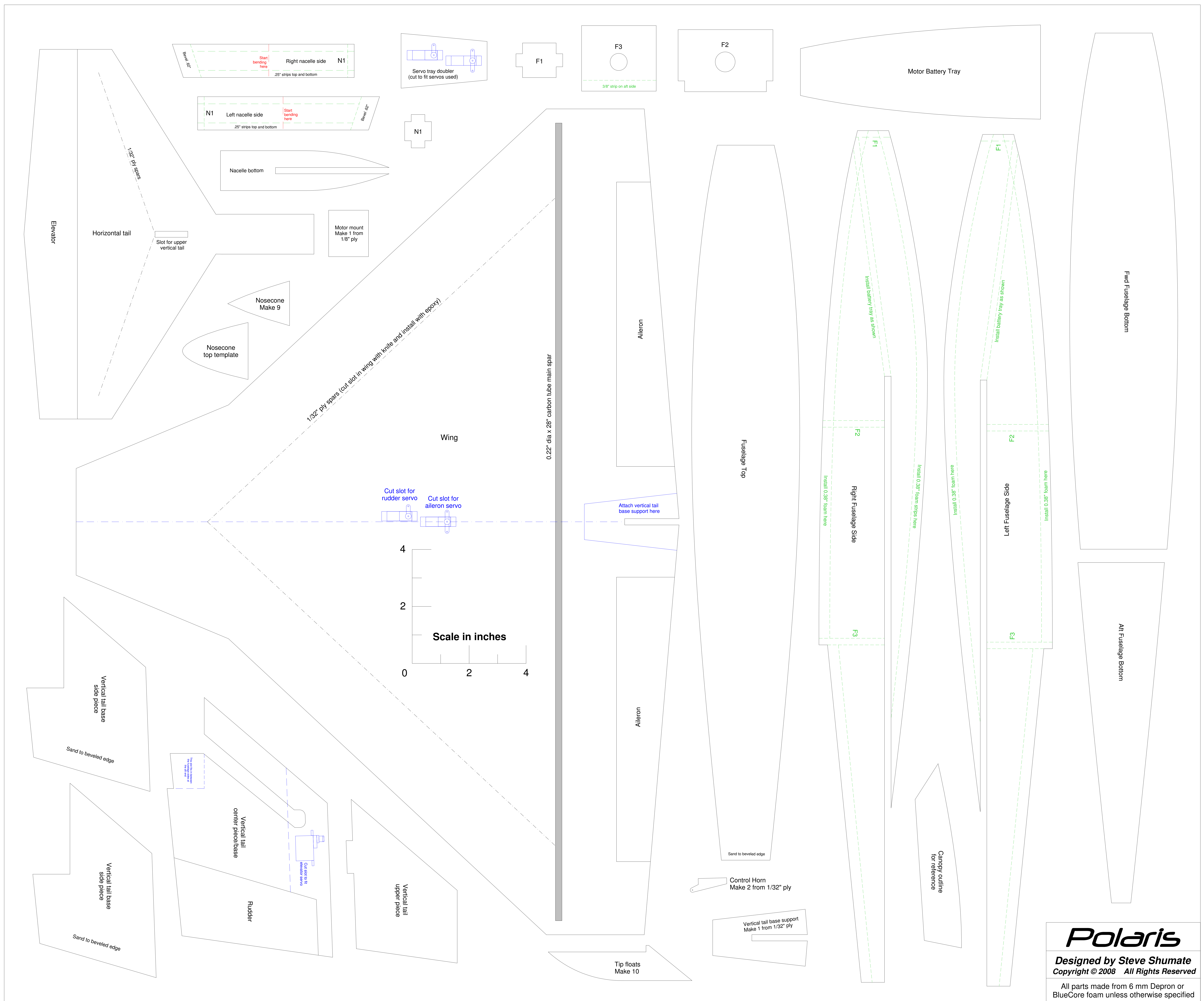

Polaris
 Designed by Steve Shumate
 Copyright © 2008 All Rights Reserved
 All parts made from 6 mm Depron or BlueCore foam unless otherwise specified