

NOTES:

- * All parts made from 6mm Depron or BlueCore foam unless otherwise indicated
- * Taileron flight controls recommended
- * Rudder and thrust vectoring are optional
- * Recommended control deflections (all dimensions measured at root trailing edge):
 Stabilators (pitch): +/- 1.5" (-30% expo)
 Stabilators (roll): +/- 1.5" (-30% expo)
 Rudder: +/- .75"
 Thrust vectoring (both pitch and roll): +/- 1.0" (measured at spinner)

RECOMMENDED POWER SETUP:

- * Two Littlecreamers Park Jet motors
- * APC 6x4E regular and pusher props (counter-rotating)
- * Two Castle Creations Phoenix 25 or Thunderbird 18 ESCs
- * Thunder Power 2100 mAh 11.1V Pro Lite battery

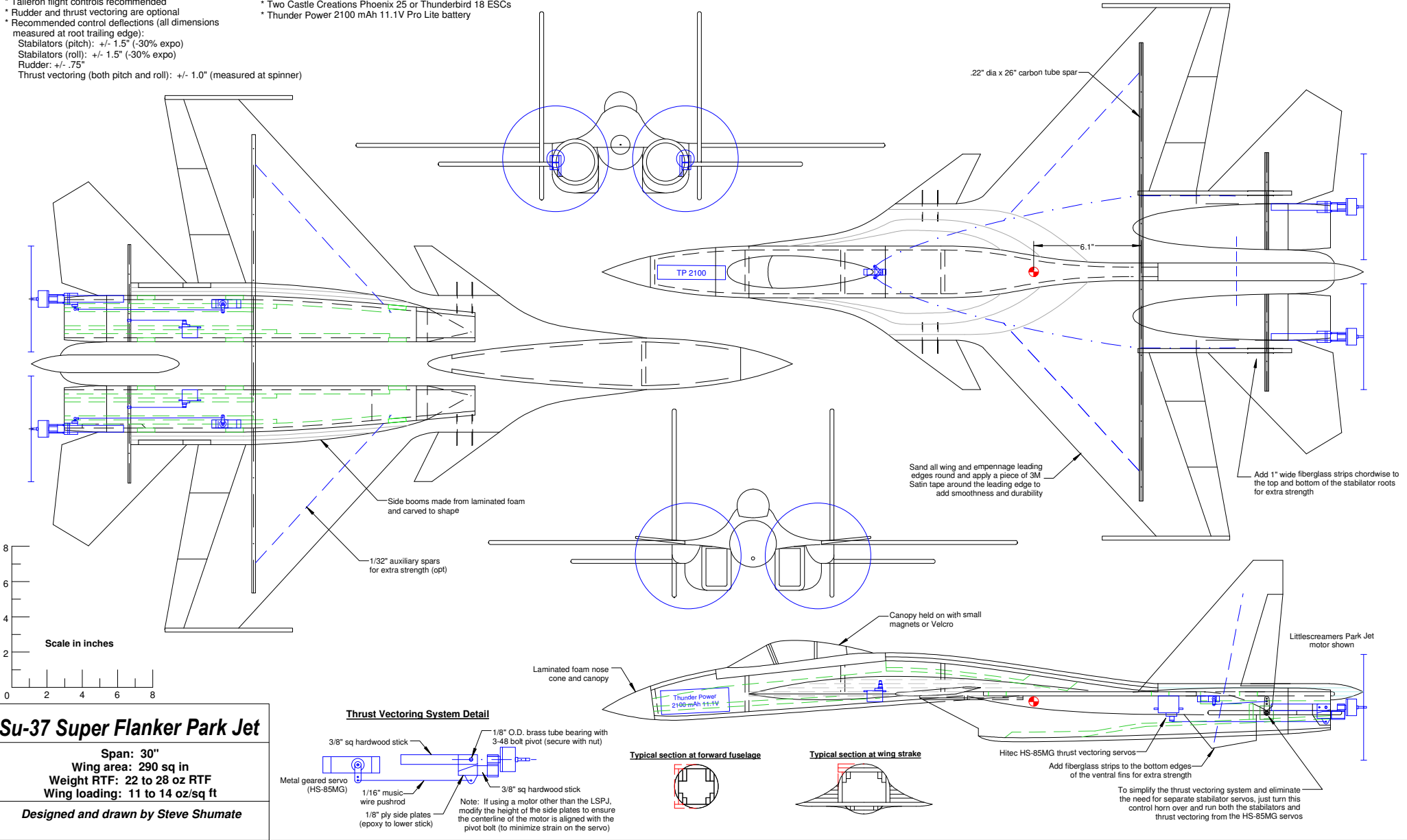

Su-37 Super Flanker Park Jet

Span: 30"
 Wing area: 290 sq in
 Weight RTF: 22 to 28 oz RTF
 Wing loading: 11 to 14 oz/sq ft

Designed and drawn by Steve Shumate

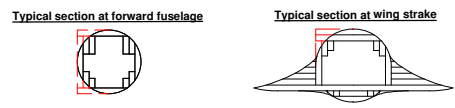
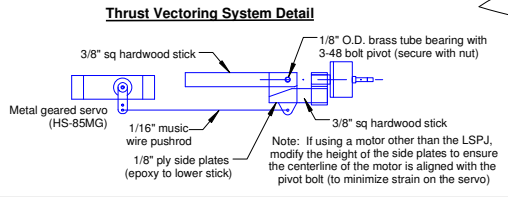

Hitex HS-85MG thrust vectoring servos

Add fiberglass strips to the bottom edges of the ventral fins for extra strength

To simplify the thrust vectoring system and eliminate the need for separate stabilator servos, just turn this control horn over and run both the stabilators and thrust vectoring from the HS-85MG servos

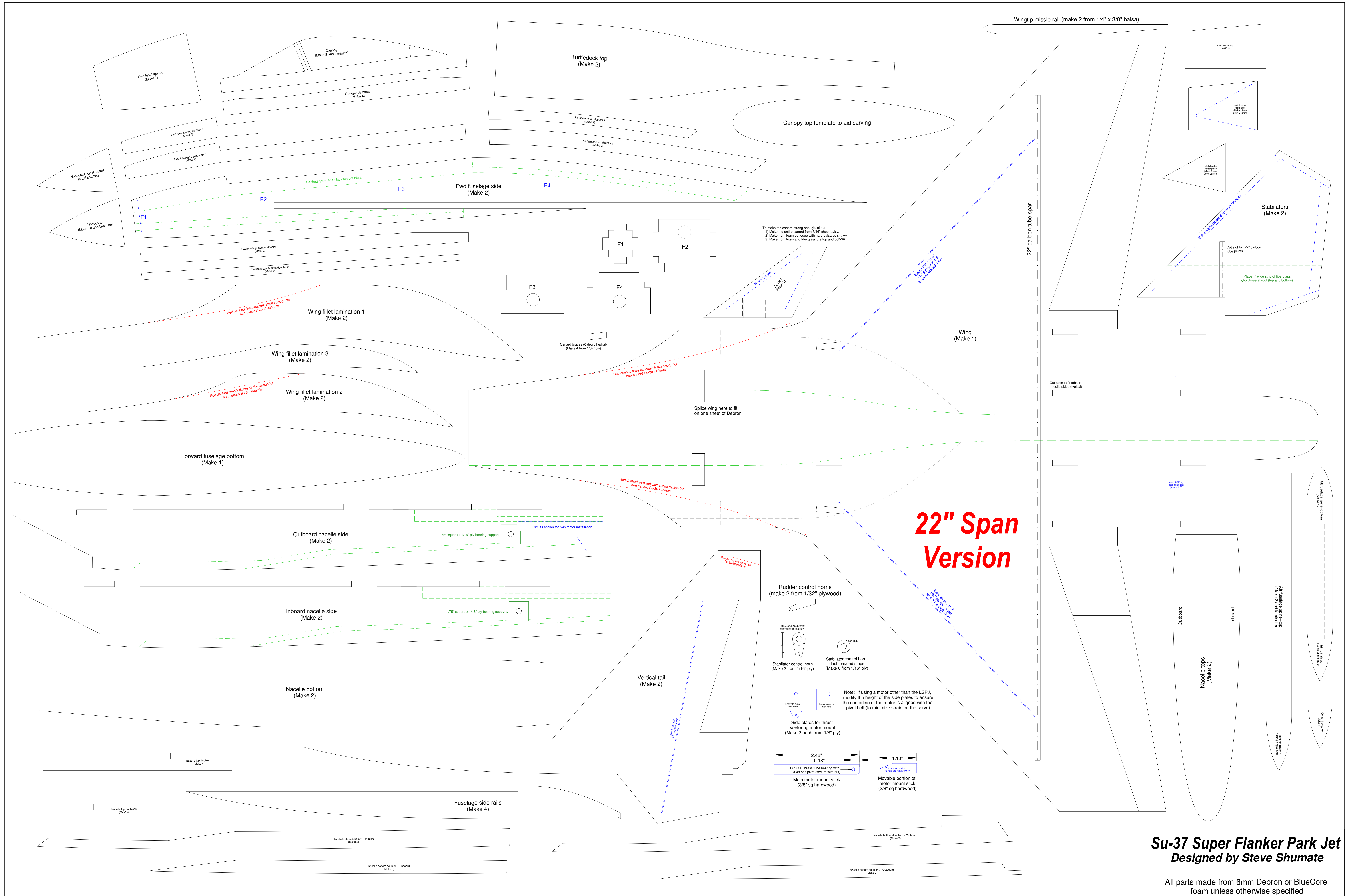

22" Span Version

Su-37 Super Flanker Park Jet Designed by Steve Shumate

All parts made from 6mm Depron or BlueCore foam unless otherwise specified

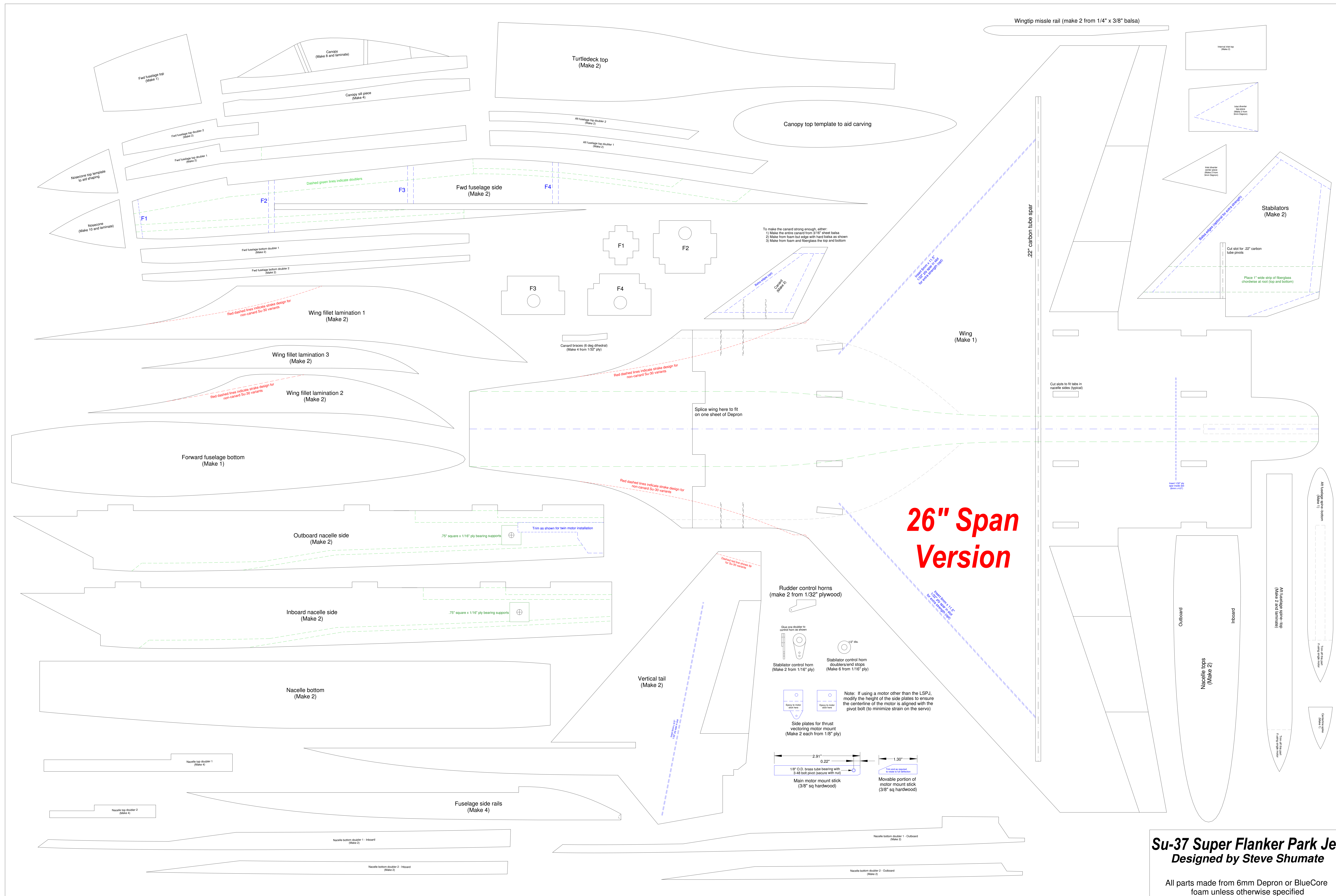

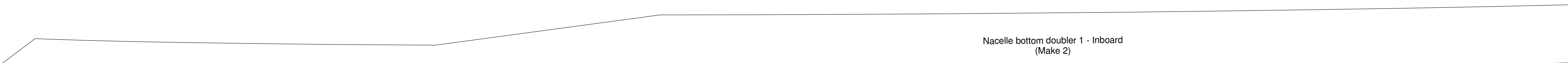
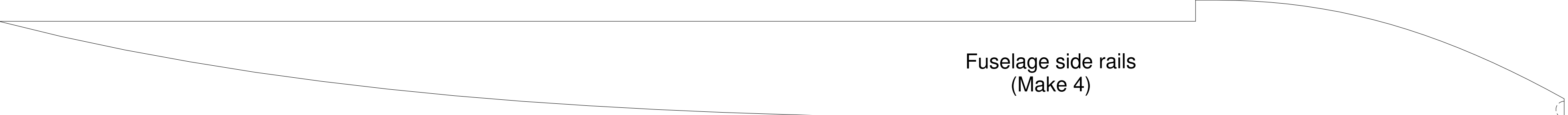
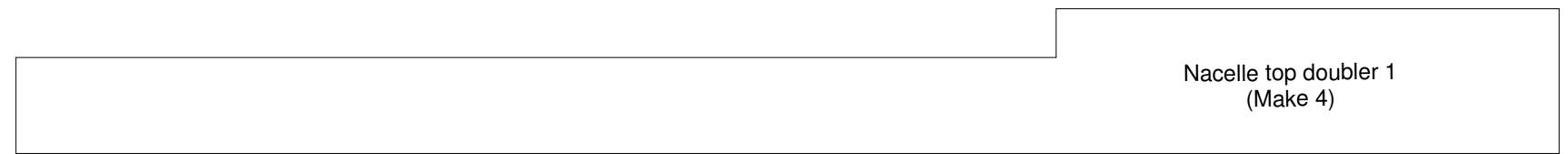
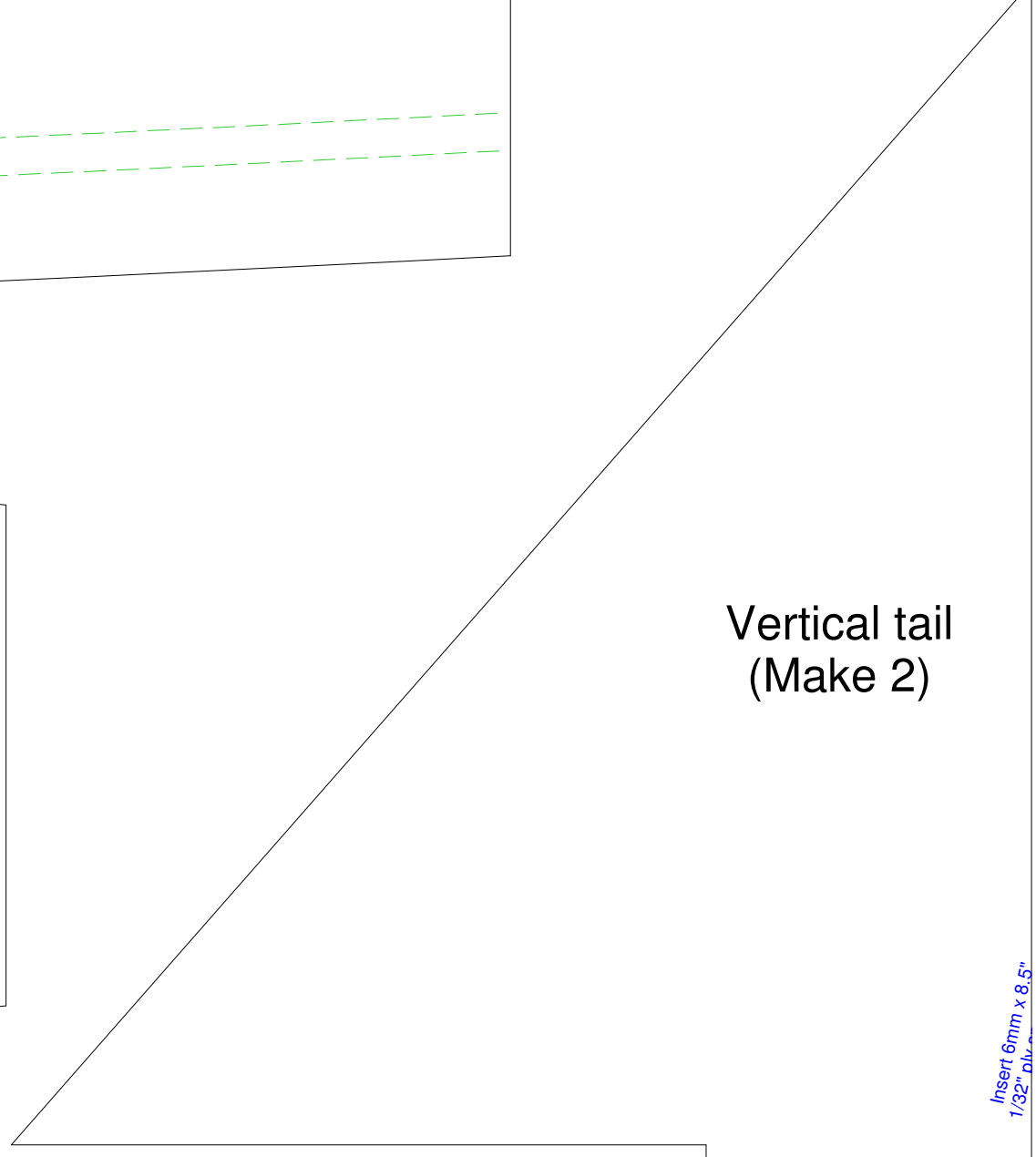
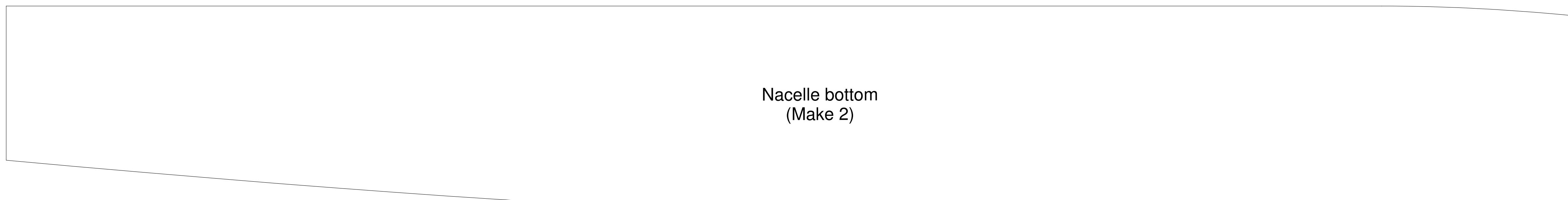
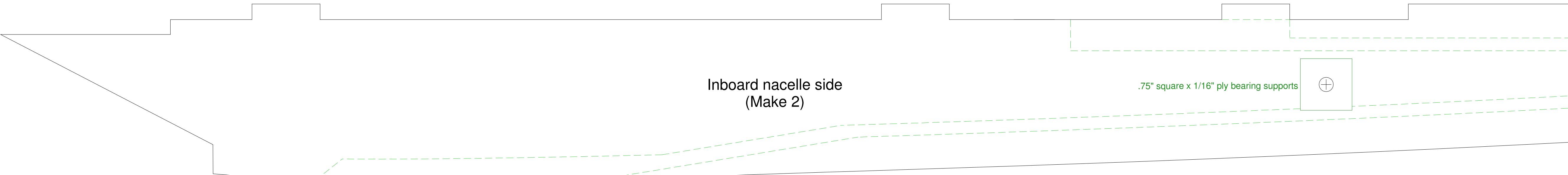
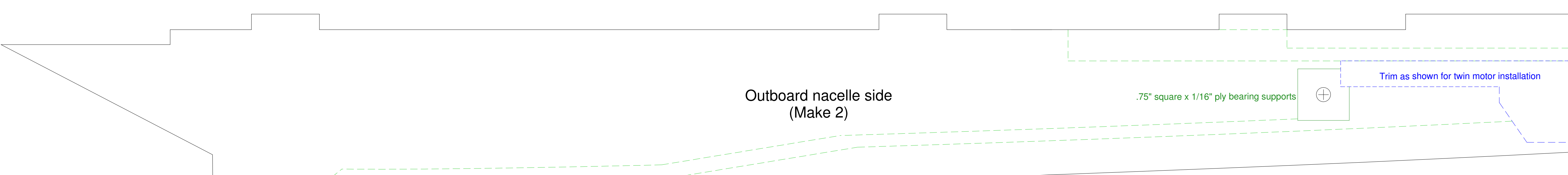
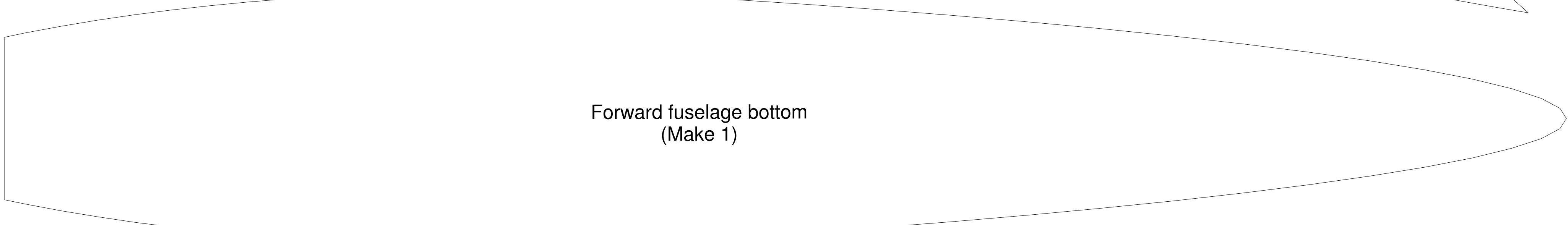
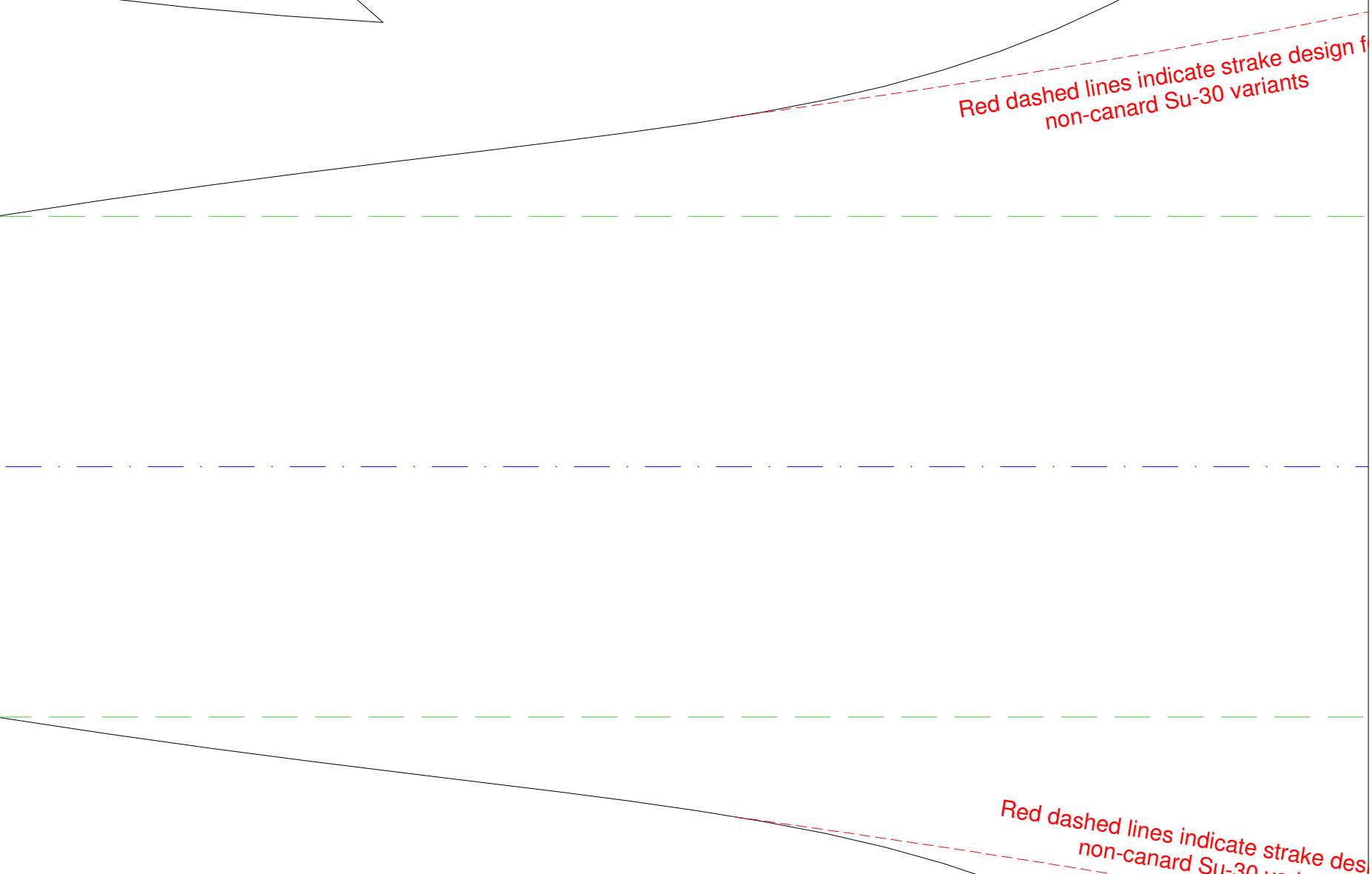
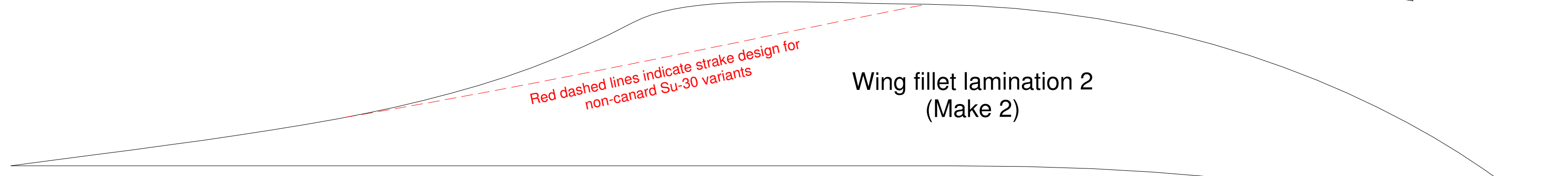
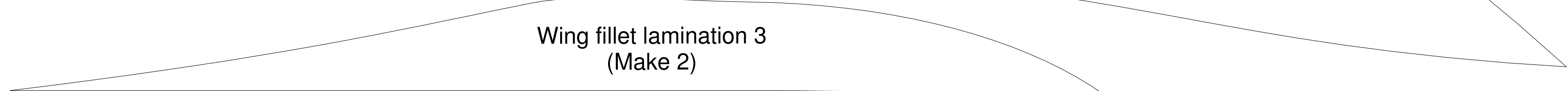
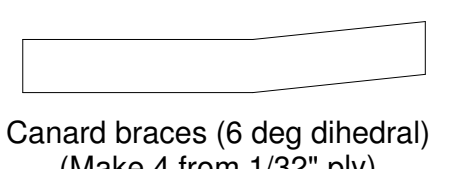
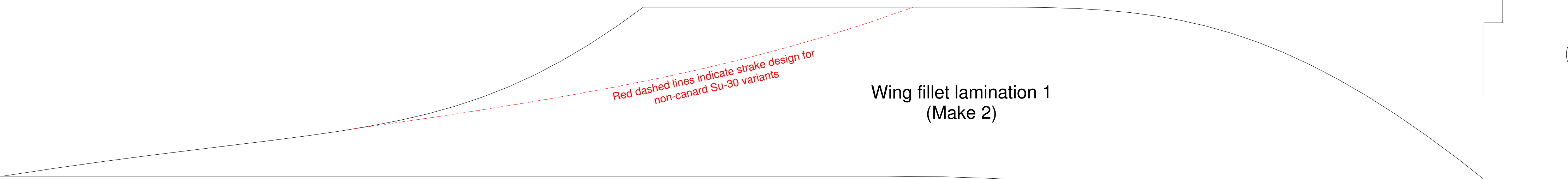
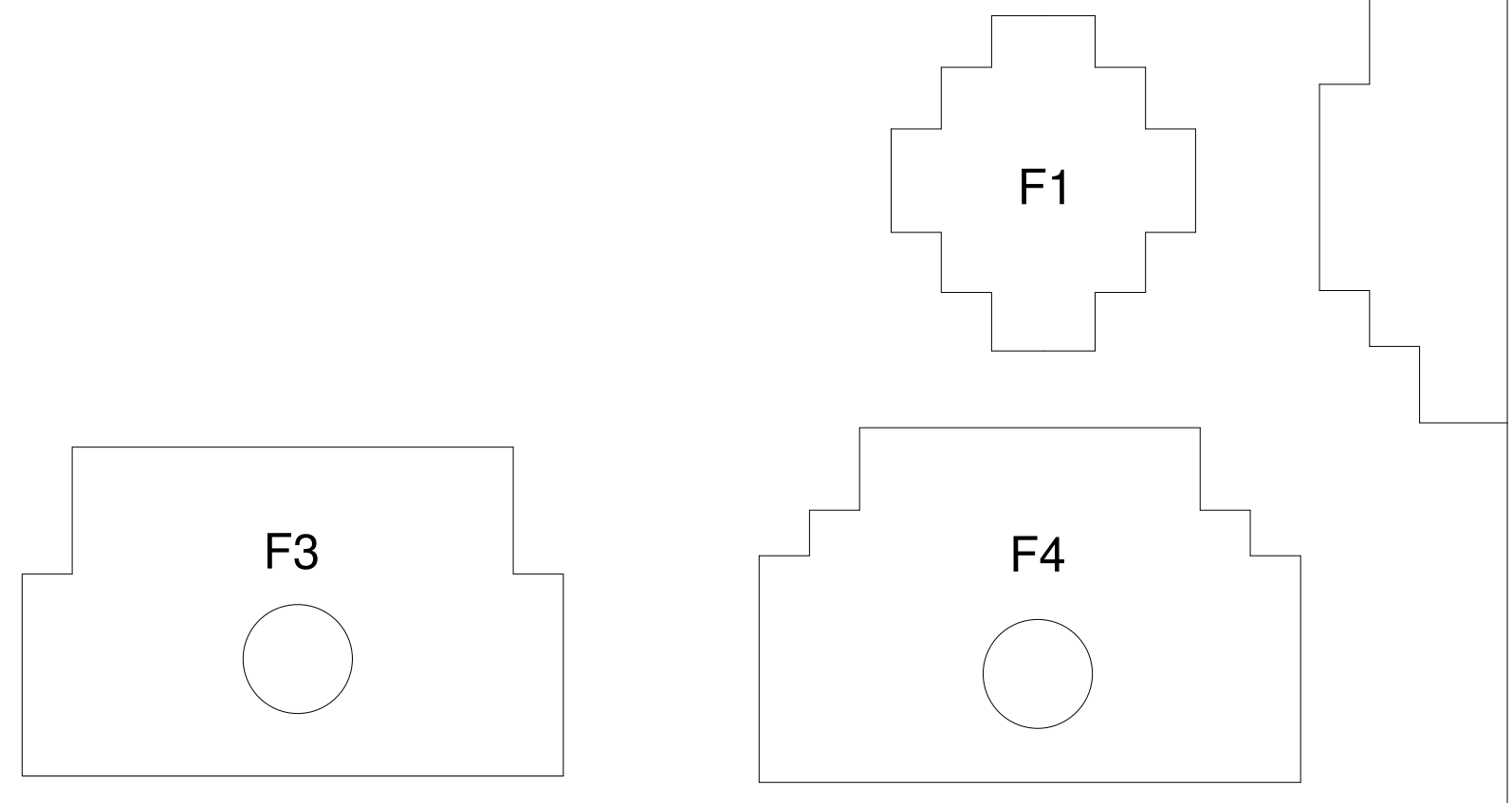
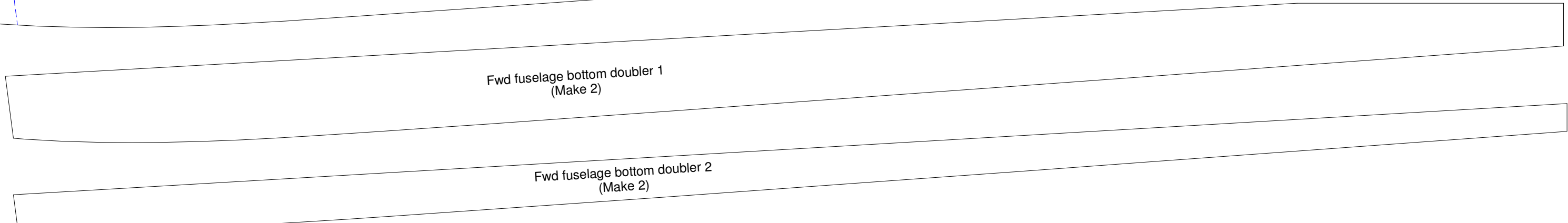
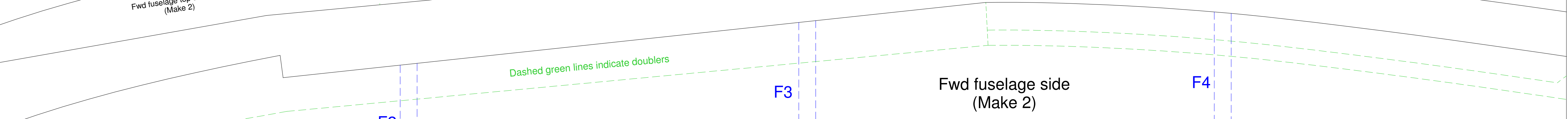
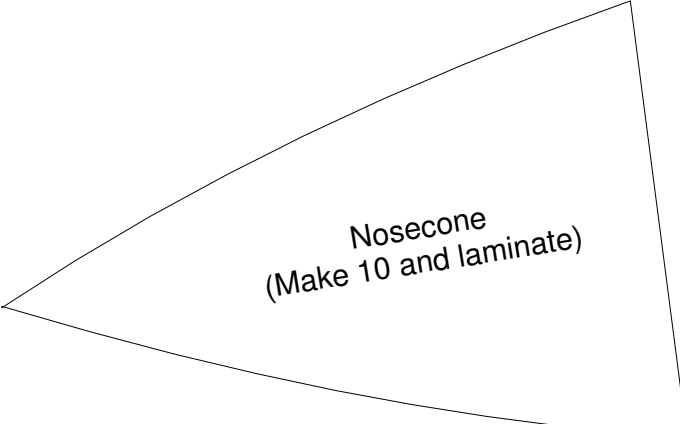
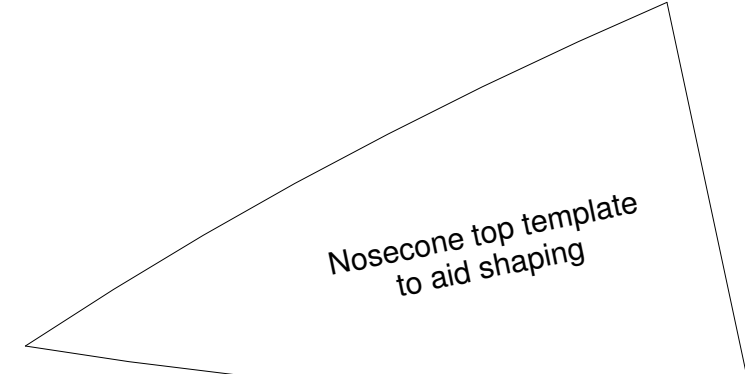
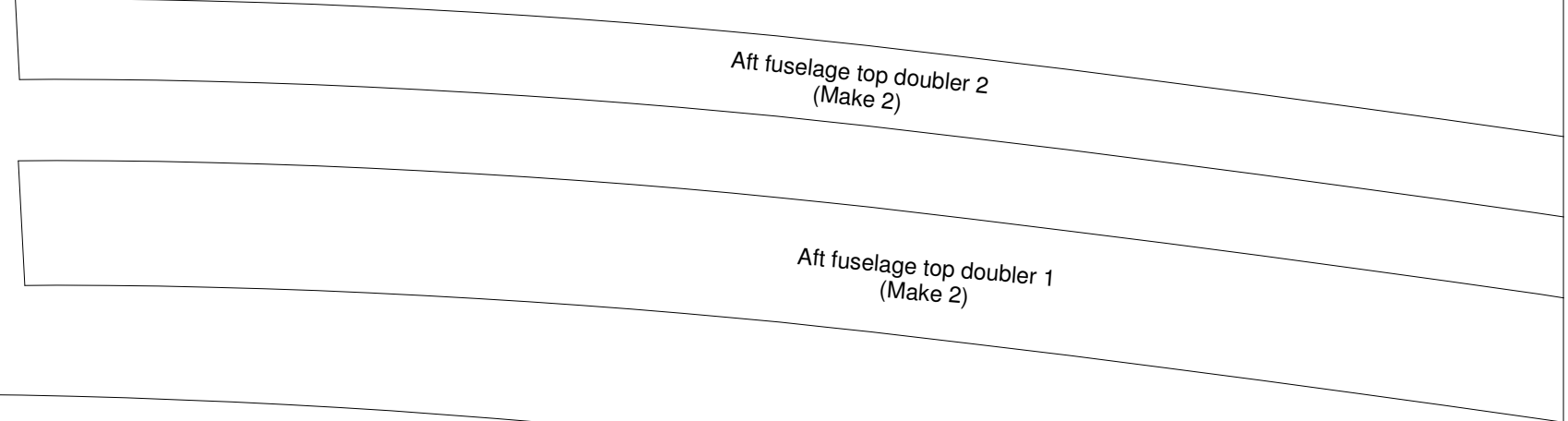
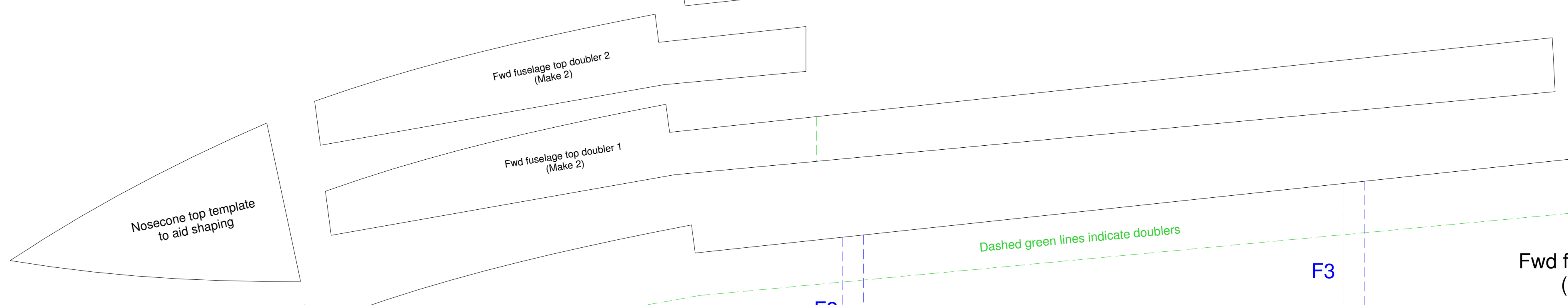
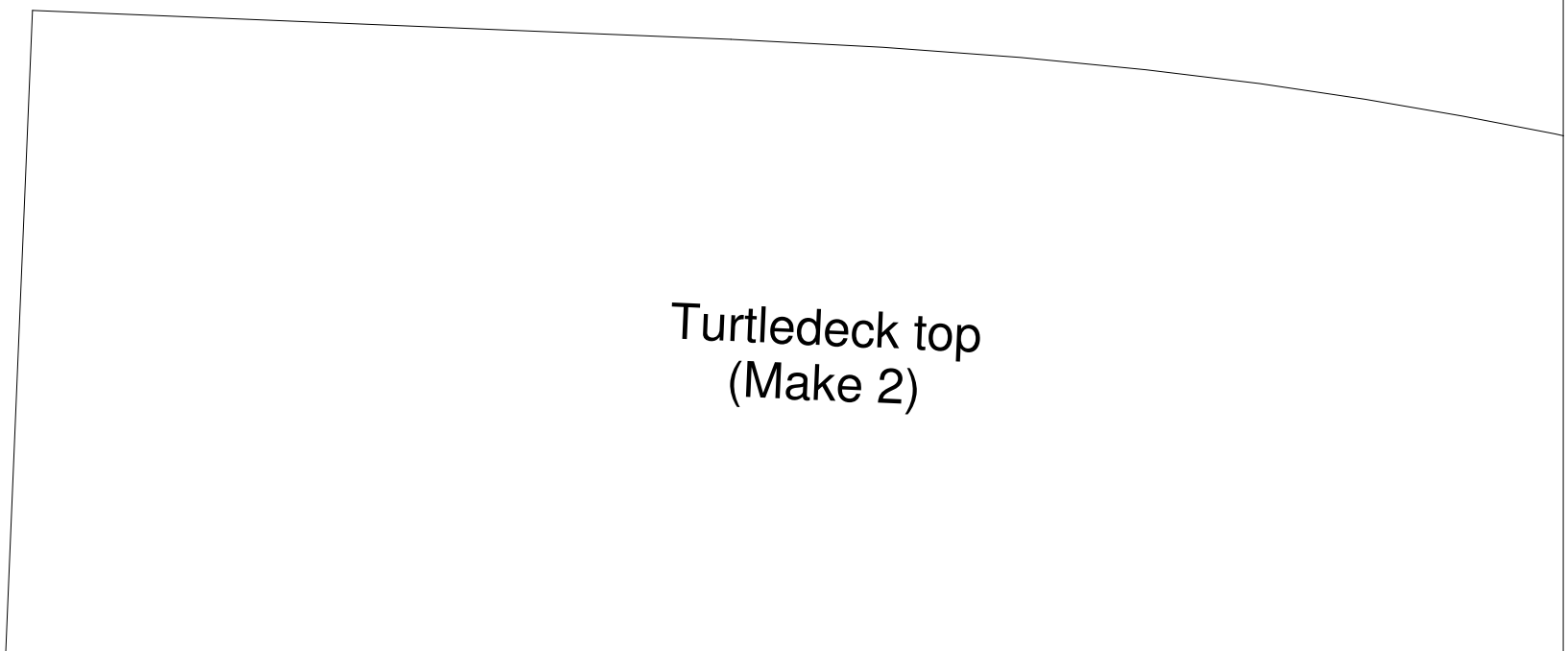
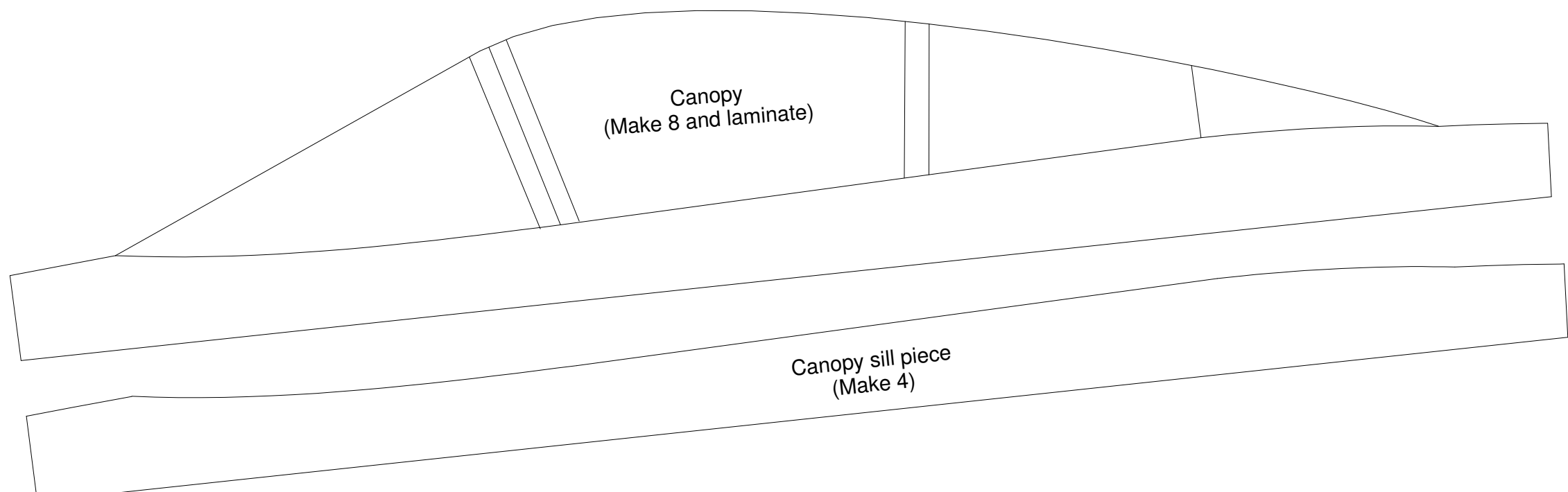
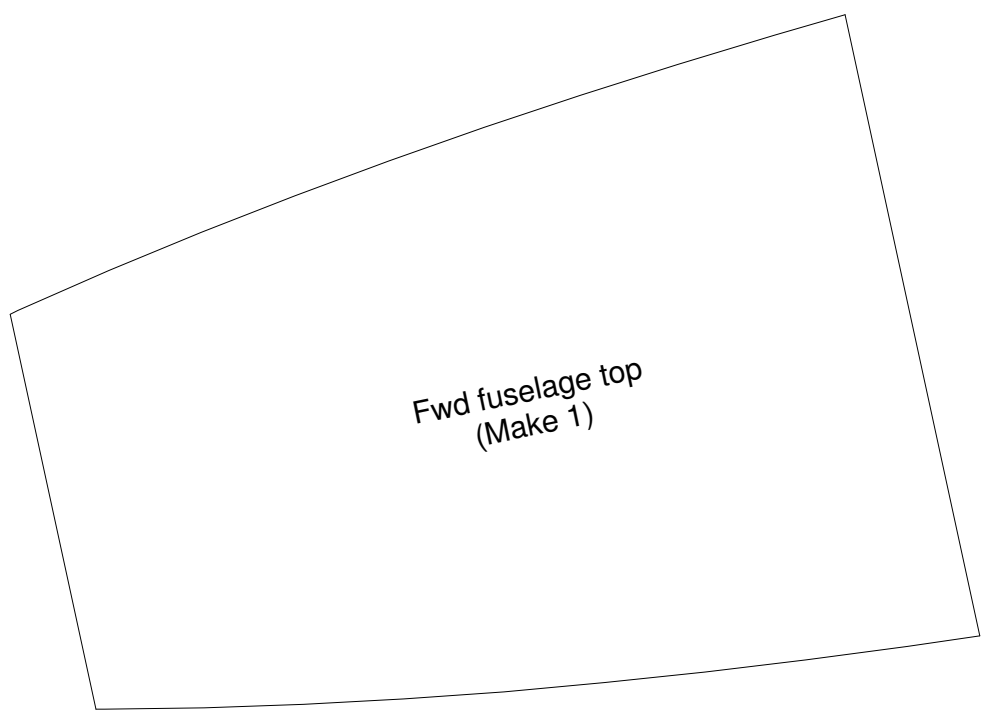

Wingtip missile rail (make 2 from 1/4" x 3/8" balsa)

Canopy top template to aid carving

To make the canard strong enough, either:
1) Make the entire canard from 3/16" sheet balsa
2) Make from foam but edge with hard balsa as shown
3) Make from foam and fiberglass the top and bottom

F2

Balsa edges (opt)
Canard (Make 2)

Insert 6mm x 11.5" 1/32" ply spar in slot for extra strength (opt)

Wing (Make 1)

Splice wing here to fit on one sheet of Depron

.22" carbon tube spar

Internal inlet top (Make 2)

Inlet diverter top piece (Make 2 from 3mm Depron)

Inlet diverter center piece (Make 2 from 3mm Depron)

Stabilators (Make 2)

Cut slot for .22" carbon tube pivots

Place 1" wide strip of fiberglass chordwise at root (top and bottom)

Cut slots to fit tabs in nacelle sides (typical)

Insert 1/32" ply spar inside slot (6mm x 4.0")

Insert 6mm x 11.5" 1/32" ply spar in slot for extra strength (opt)

Rudder control horns (make 2 from 1/32" plywood)

Glue one doubler to control horn as shown

Stabilator control horn (Make 2 from 1/16" ply)

Stabilator control horn doublers/end stops (Make 6 from 1/16" ply)

Note: If using a motor other than the LSPJ, modify the height of the side plates to ensure the centerline of the motor is aligned with the pivot bolt (to minimize strain on the servo)

Side plates for thrust vectoring motor mount (Make 2 each from 1/8" ply)

Main motor mount stick (3/8" sq hardwood)

Movable portion of motor mount stick (3/8" sq hardwood)

4.03" 0.30" 1.80"

1/8" O.D. brass tube bearing with 3-48 bolt pivot (secure with nut)

Trim and as required to rotate to full deflection

Nacelle bottom doubler 1 - Outboard (Make 2)

Nacelle bottom doubler 2 - Outboard (Make 2)

Outboard

Inboard

Nacelle tops (Make 2)

All fuselage spine-top (Make 2 and trim)

All fuselage spine-bottom (Make 1)

Trim off this part if using single motor

Centerline spine (Make 1)

Trim off this part if using single motor

Su-37 Super Flanker Park Jet

Designed by Steve Shumate

All parts made from 6mm Depron or BlueCore foam unless otherwise specified



Su-37 Super Flanker Park Jet
Designed by Steve Shumate

All parts made from 6mm Depron or BlueCore foam unless otherwise specified