

**FUSELAGE-BOTTOM VIEW**

**NOTE:**  
FUSELAGE IS BUILT UPSIDE DOWN OVER PLAN

PIN CROSS BRACES AND STAB. BASE TO PLAN THEN SQUARE UP FORMERS AND FUSELAGE SIDES. TURTLE DECK IS BUILT LAST THING AFTER STAB. AND WING ARE ALIGNED UPSIDE DOWN ON A FLAT SURFACE.

**NOTE**  
LEFT FUSELAGE SIDE (PORT) IS 3/32\"/>

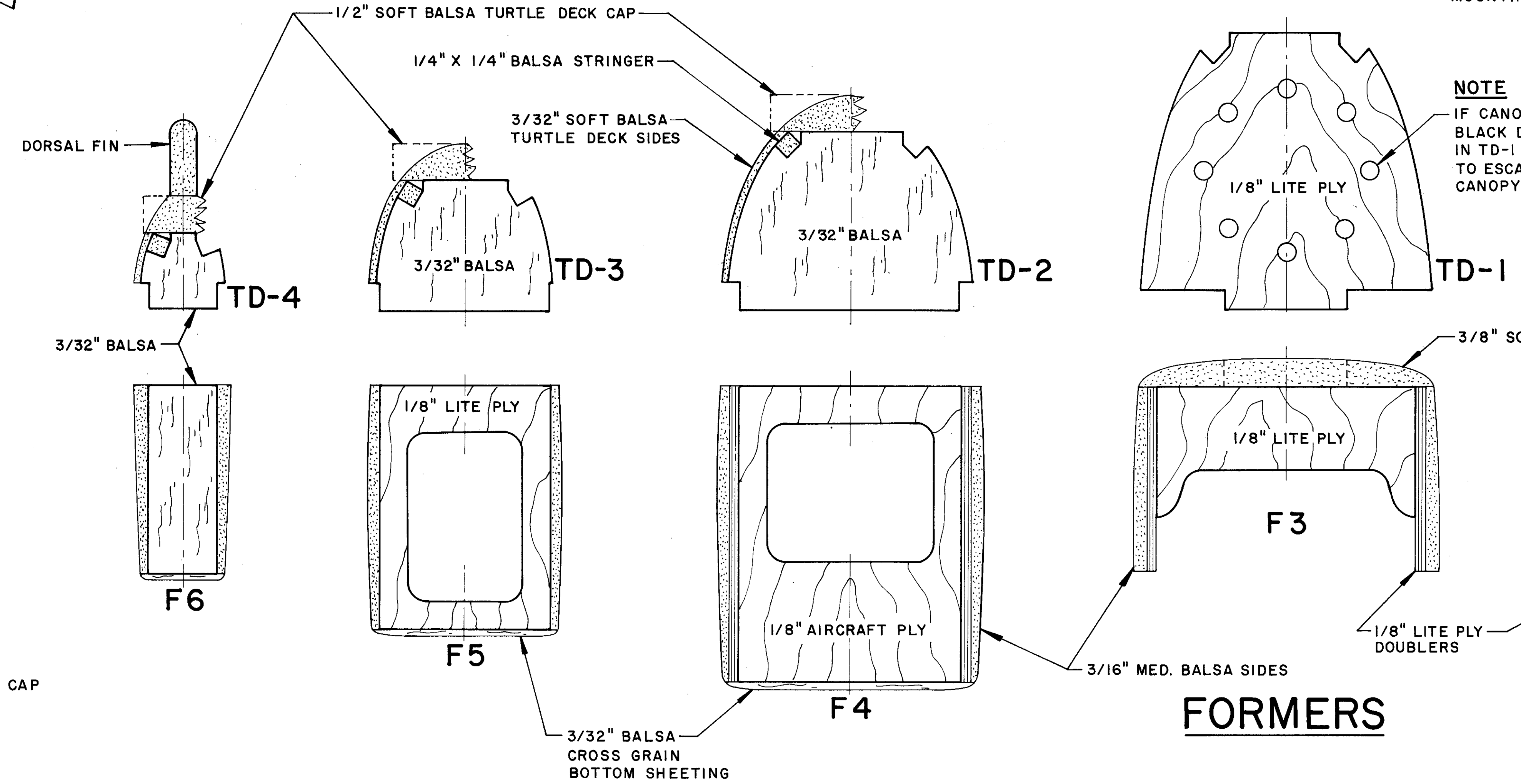

**FORMERS**

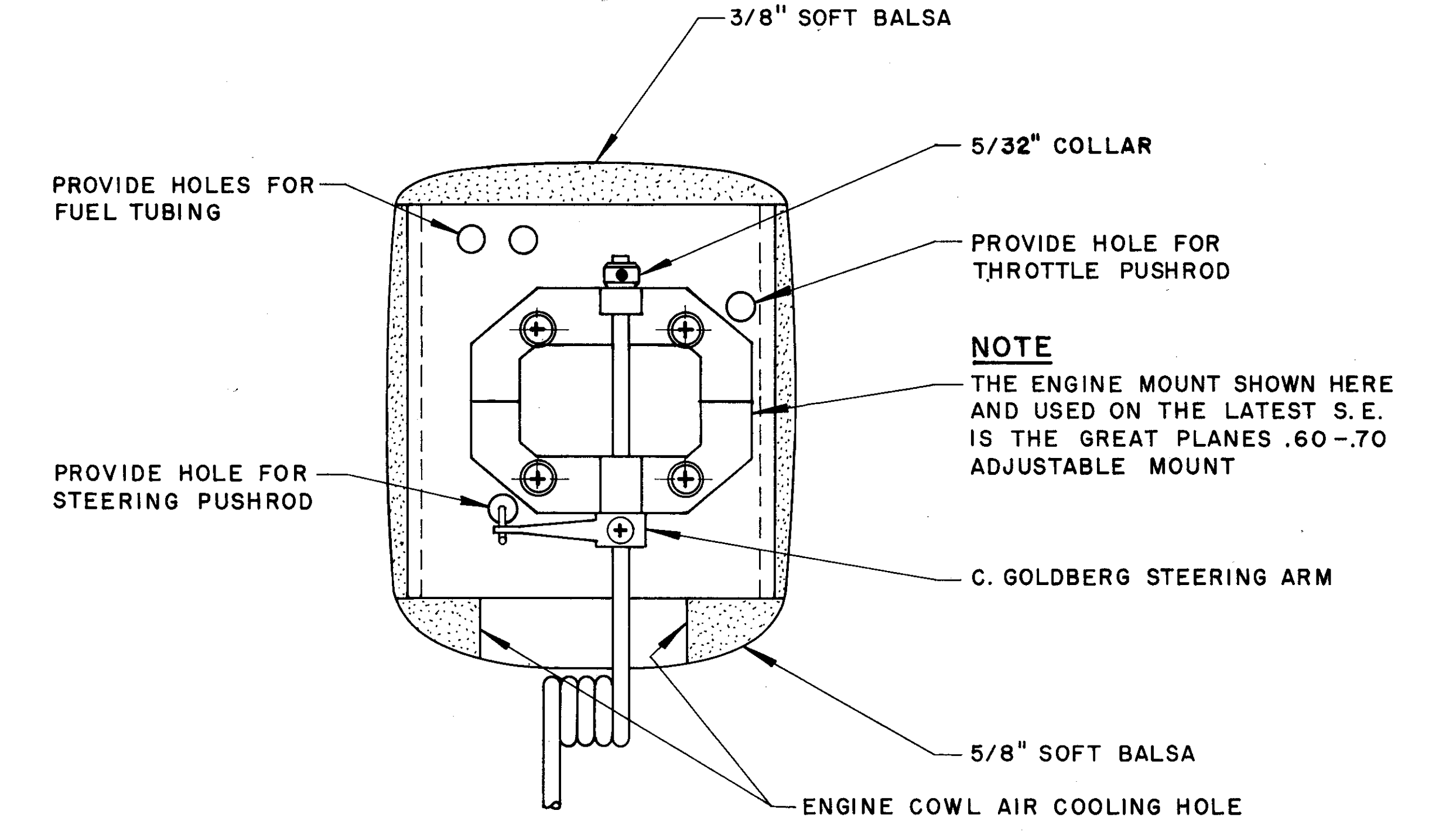

**FRONT VIEW**

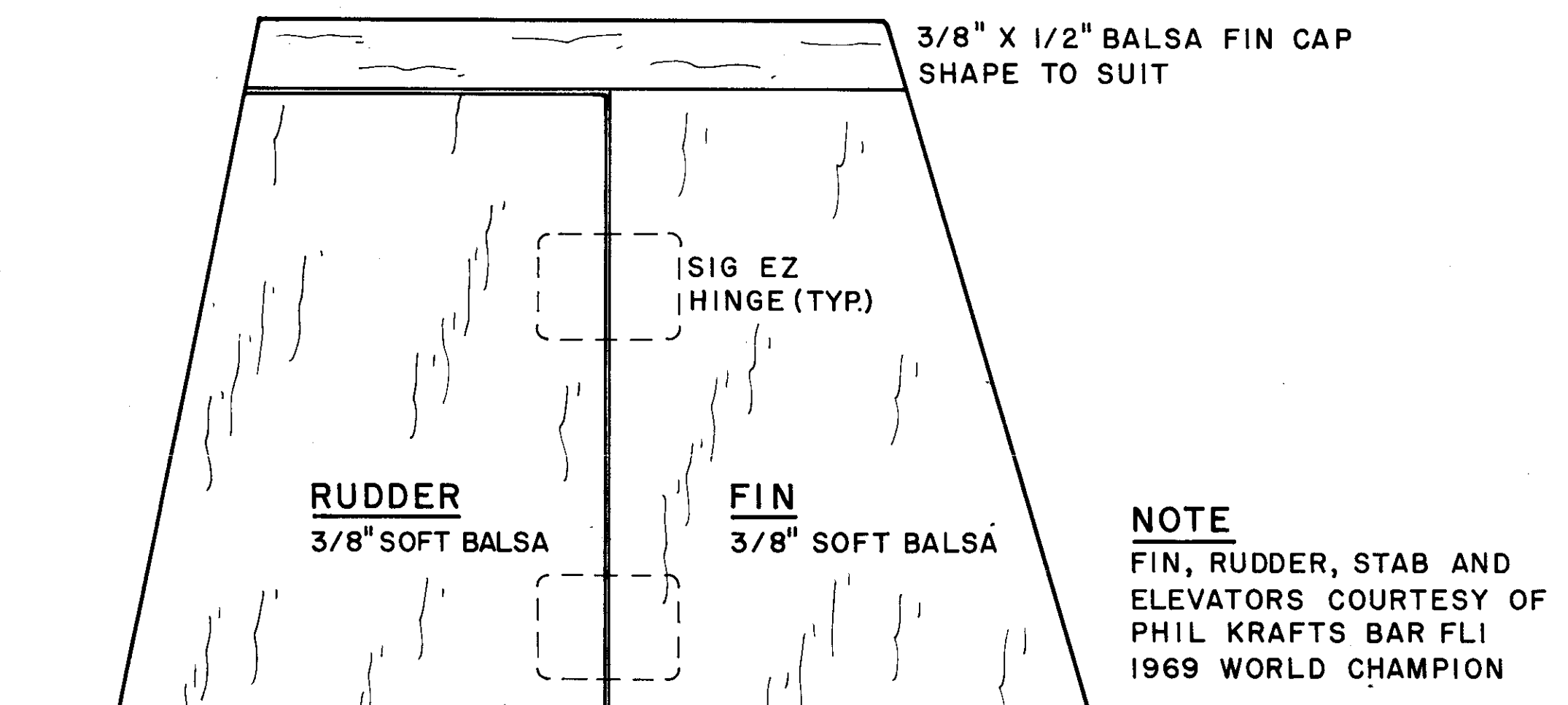

**NOTE**  
FIN, RUDDER, STAB AND ELEVATORS COURTESY OF PHIL KRAFT'S BAR FLI 1969 WORLD CHAMPION

**TURTLE DECK**  
MANY VERSIONS HAVE BEEN TRIED. THE ORIGINAL S.E. WAS STRINGERED ALA THE BAR-FLI. USE OF CONTEST Balsa AND BUILT UP EMPENAGE RESULTED IN A WEIGHT OF 4-1/2 LBS., BUT DID NOT FLY WELL IN WINDY CONDITIONS. SILK AND DOPE NOT USED SINCE MONOKOTO WAS INTRODUCED IN THE 70'S. THE TURTLE DECK MAKES KNIFE EDGE FLIGHT POSSIBLE, BUT YOU MUST ENTER WITH THE LEFT(PORT) WING DOWN DUE TO THE 2° RIGHT THRUST

**NOTE**  
NOSE, CANOPY AND TURTLE DECK COURTESY OF JIM(DADDY RABBIT) WHITLEY, CLIFF(CANDY) WEIRICK AND DR. D.B.(BINGO) MATHEWS. ALSO, ED(TAURUS) KAZMIRSKI.

**CANOPY**  
YOUR OPTION. ORIGINAL WAS CUT DOWN TOP FLITE TAURUS. LATER VERSIONS USED SIG WWII SERIES. LAST TWO USED ACE BINGO CANOPIES ALL SPRAYED BLACK INSIDE FOR VISIBILITY, ATTACHED WITH R/C-56 CANOPY CEMENT.



**FUSELAGE-SIDE VIEW**

© RCM ALL COMMERCIAL RIGHTS RESERVED

**SOUTHERN EAGLE**

DESIGNED BY: BILL PROFFITT  
PLANS BY: RODNEY HELGELAND

0 1 2 3 4 5 6

PLAN NO. 13027

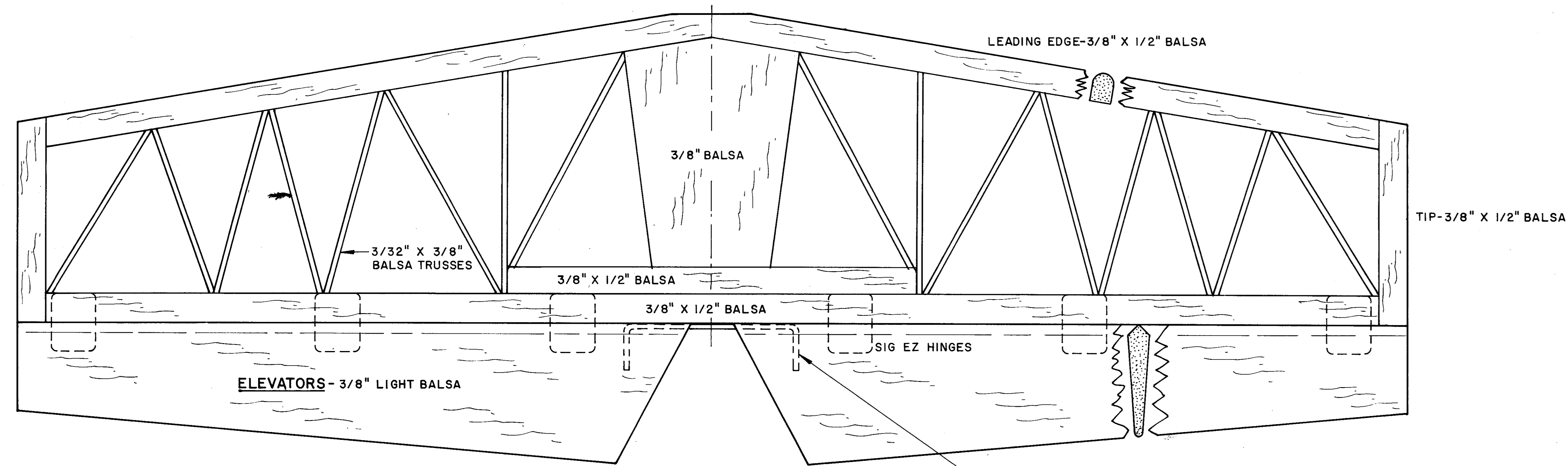

**STABILIZER & ELEVATORS**

**NOTE**  
ELEVATOR CONNECTING ROD IS BENT FROM THE H.D. WIRE FROM A PANTS TYPE COAT HANGER. THIS WILL ALLOW ONE OR BOTH ELEVATORS TO BE BENT UP OR DOWN SLIGHTLY DURING FLIGHT TRIMMING.

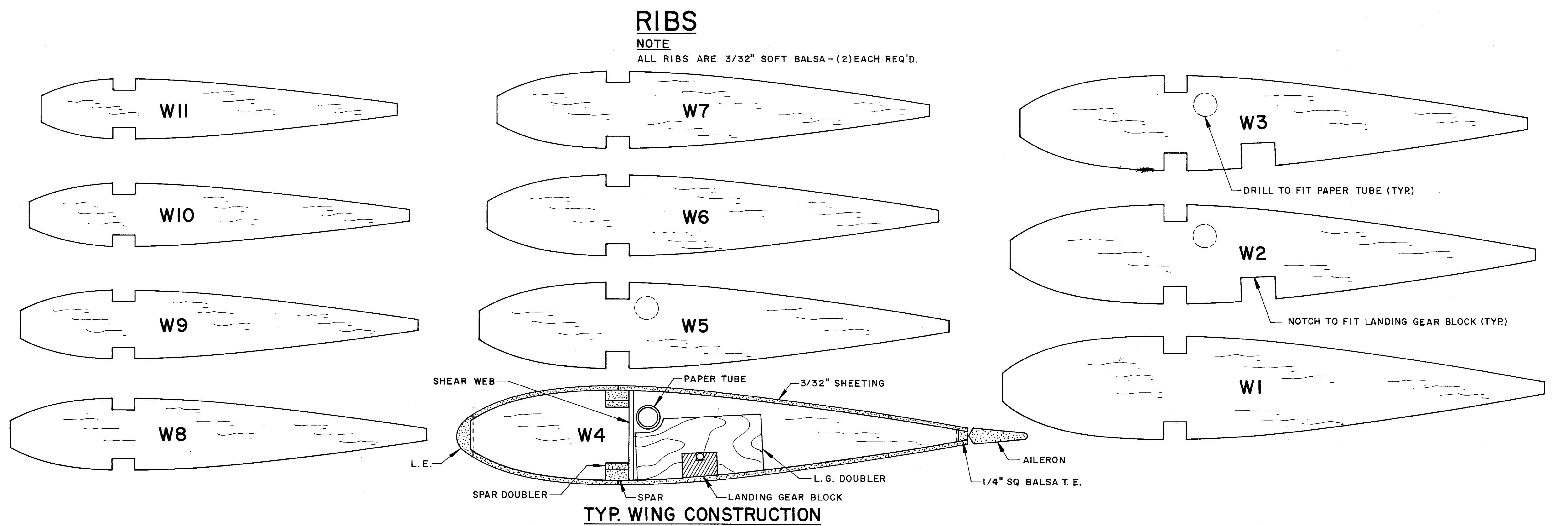
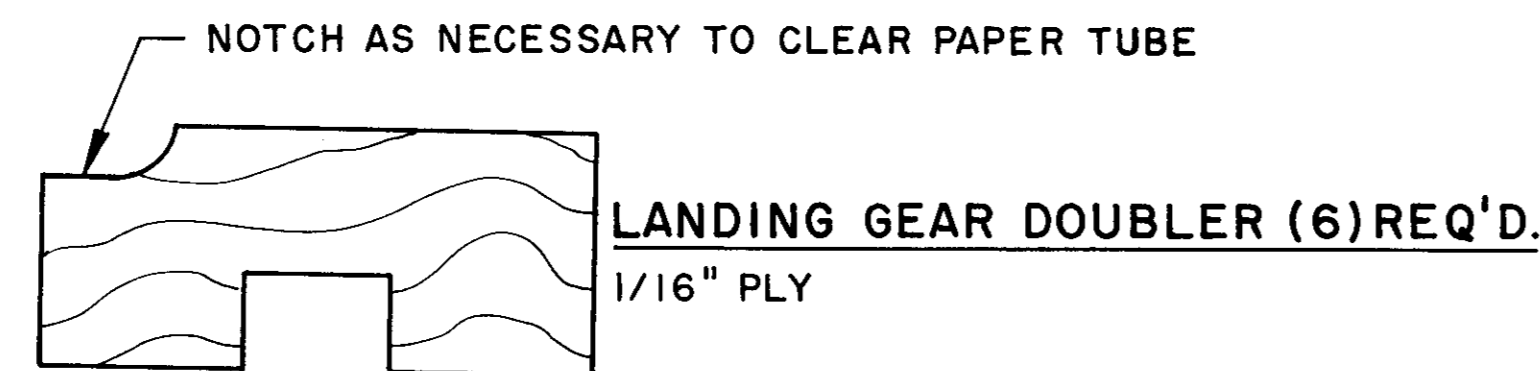
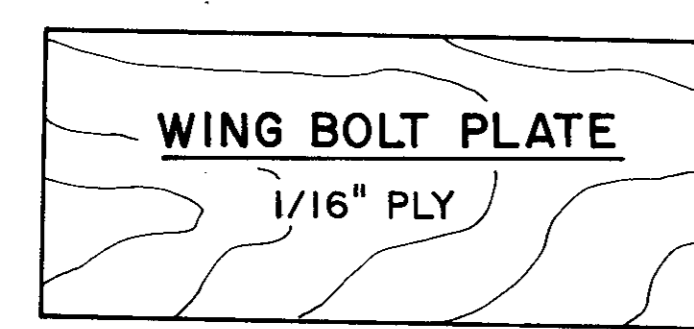
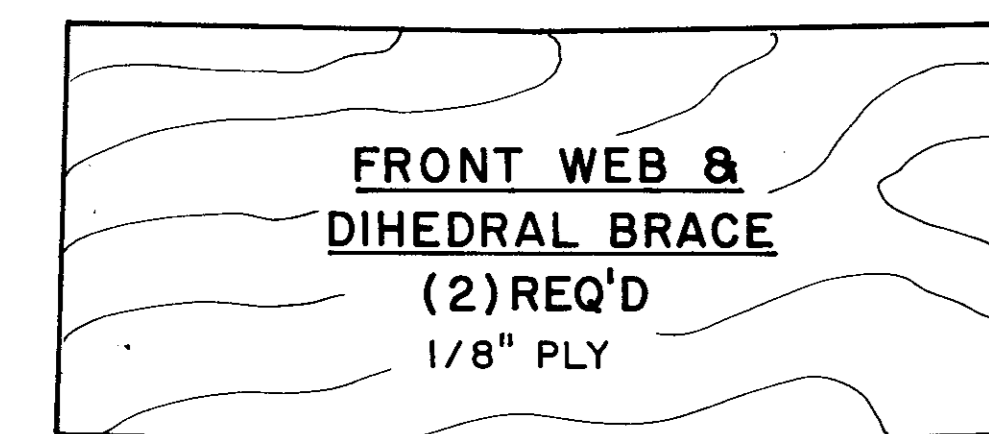

**TYP. WING CONSTRUCTION**

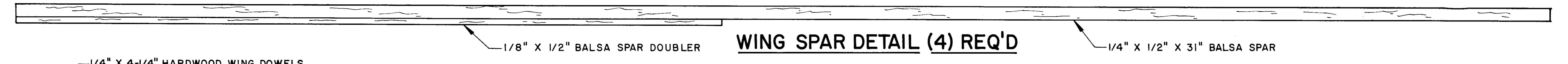

**WING SPAR DETAIL (4) REQ'D**



**LEFT WING PANEL**

**RIGHT WING PANEL**

**IMPORTANT!**  
BALANCE WING Laterally. EPOXY WEIGHT TO LIGHT WINGTIP.

**NOTE**  
ALTHOUGH ALL OUR S.E. WINGS HAVE BEEN BUILT ON AN RCM WING JIG, MANY BUILDERS PREFER THE T.E. JIG SHOWN HERE. NO WARPS—NO PROBLEMS.

**NOTE**  
SEVERAL TYPES OF WINGTIPS HAVE BEEN TESTED. BLOCKS, BUILT UP, ROUND, TRIANGULAR, ETC. WITH NO DIFFERENCE NOTED. (SQUARED TIPS ARE SIMPLER)

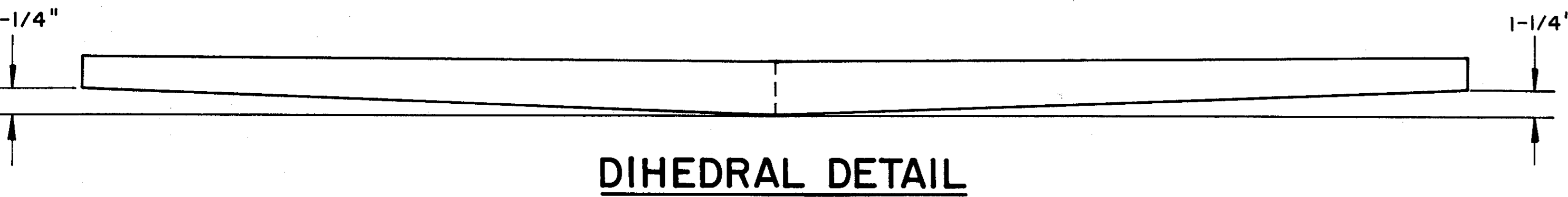

**DIHEDRAL DETAIL**

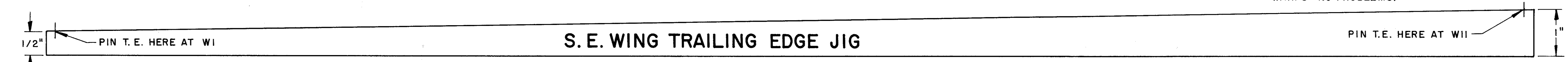

**S.E. WING TRAILING EDGE JIG**

**SOUTHERN EAGLE**

DESIGNED BY: BILL PROFFITT  
PLANS BY: RODNEY HELGELAND

WING & STAB. - SHEET 2 OF 2

PLAN NO. 1302