

CANOPY TEMPLATES

FUSELAGE TOP VIEW

HORIZONTAL STABILIZER & ELEVATOR

SECTION Y-Y

SECTION X-X

SECTION Z-Z

FUSELAGE SIDE VIEW

**Slingsby T.49b Capstan**  
 Designed by: Mike Hollison Plans by: Steve Calderon

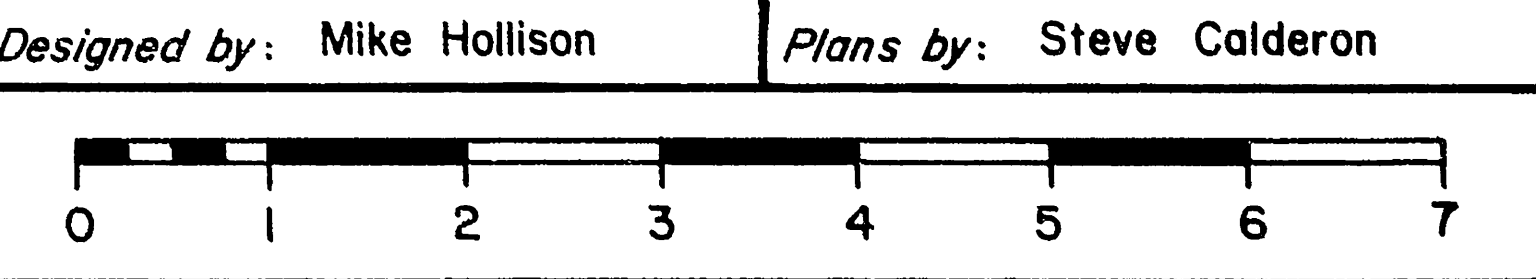

© RCM ALL COMMERCIAL RIGHTS RESERVED

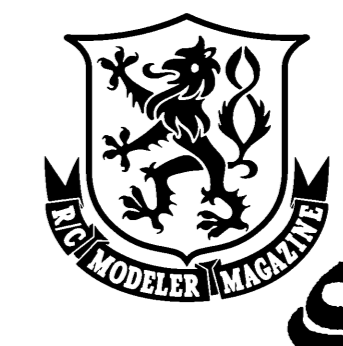
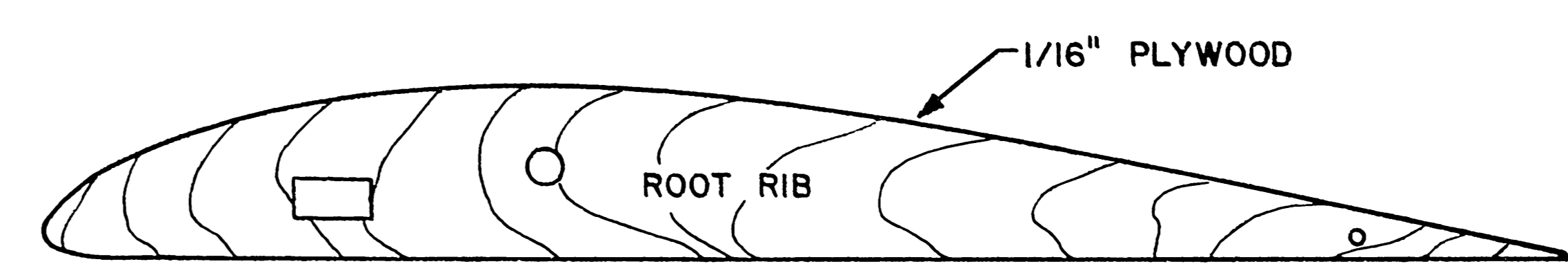
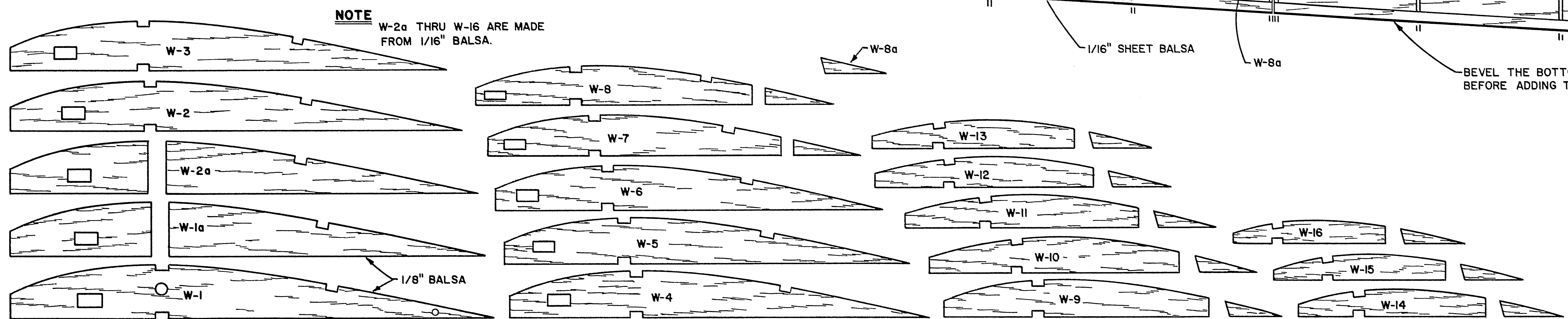

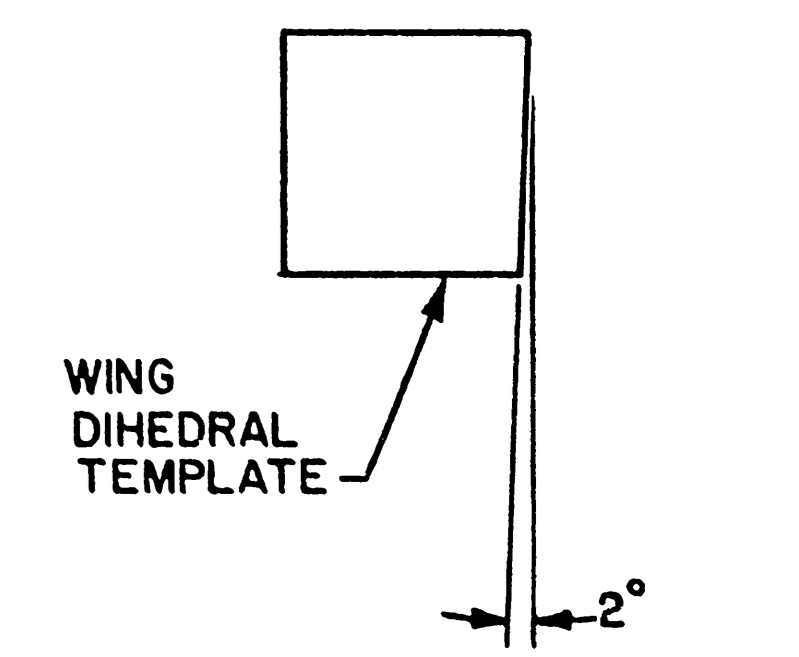
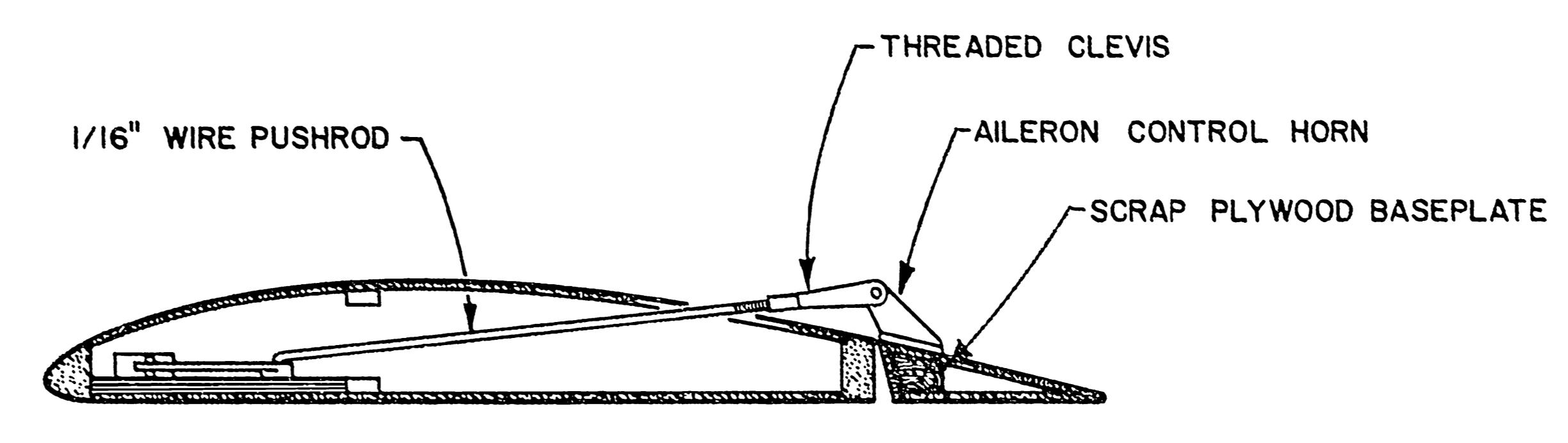
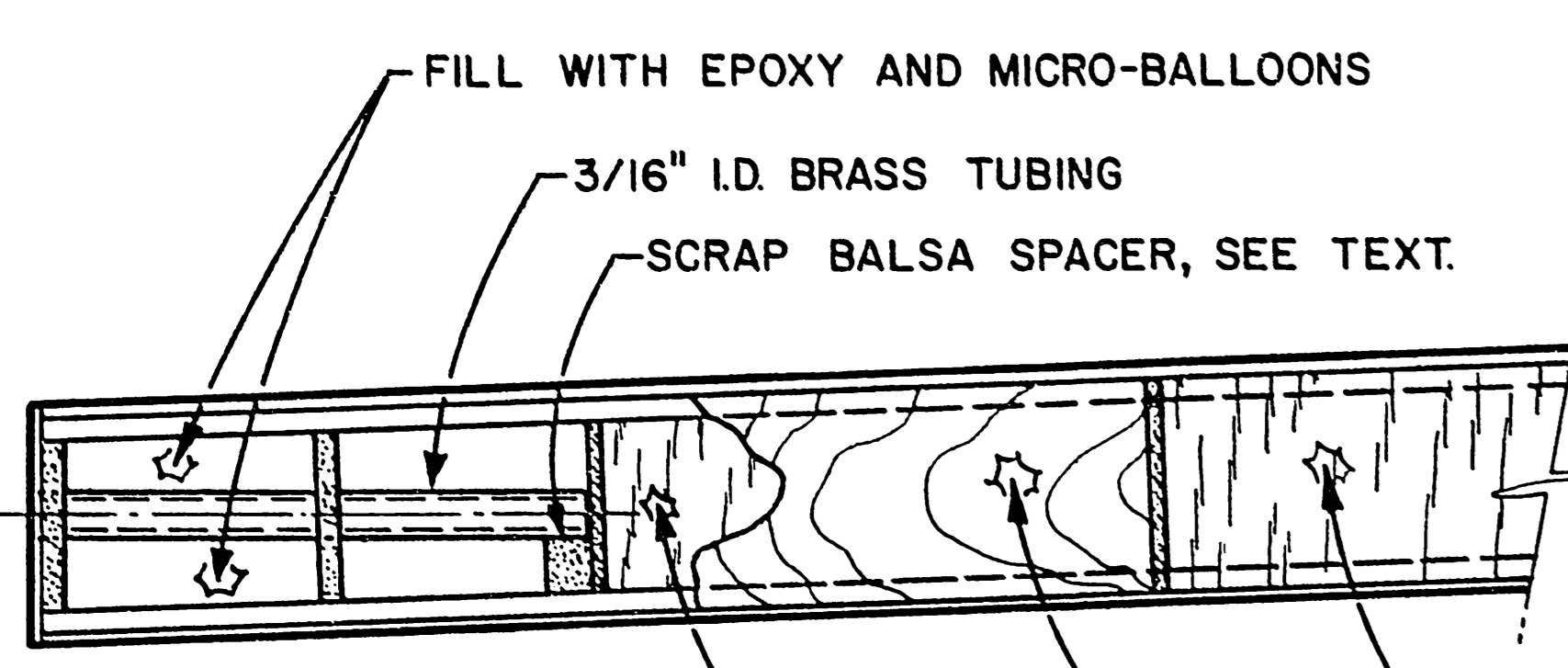


Slingsby T49b Capstan

Designed by: Mike Hollison Plans by: Steve Calderon

SHEET 2 OF 2

0 1 2 3 4 5 6 7

PLAN NO. 904