

FOAM WING CORES ARE AVAILABLE COMPLETE WITH ALL AILERONS & SPAR NOTCHES PRECUT.  
 FOR INFORMATION:  
 SEND A SELF-ADDRESSED STAMPED ENVELOPE TO:  
 HOWARD "SPINNER" SCHUTT  
 3514 BAIN PLACE, TYLER, TX.  
 75701

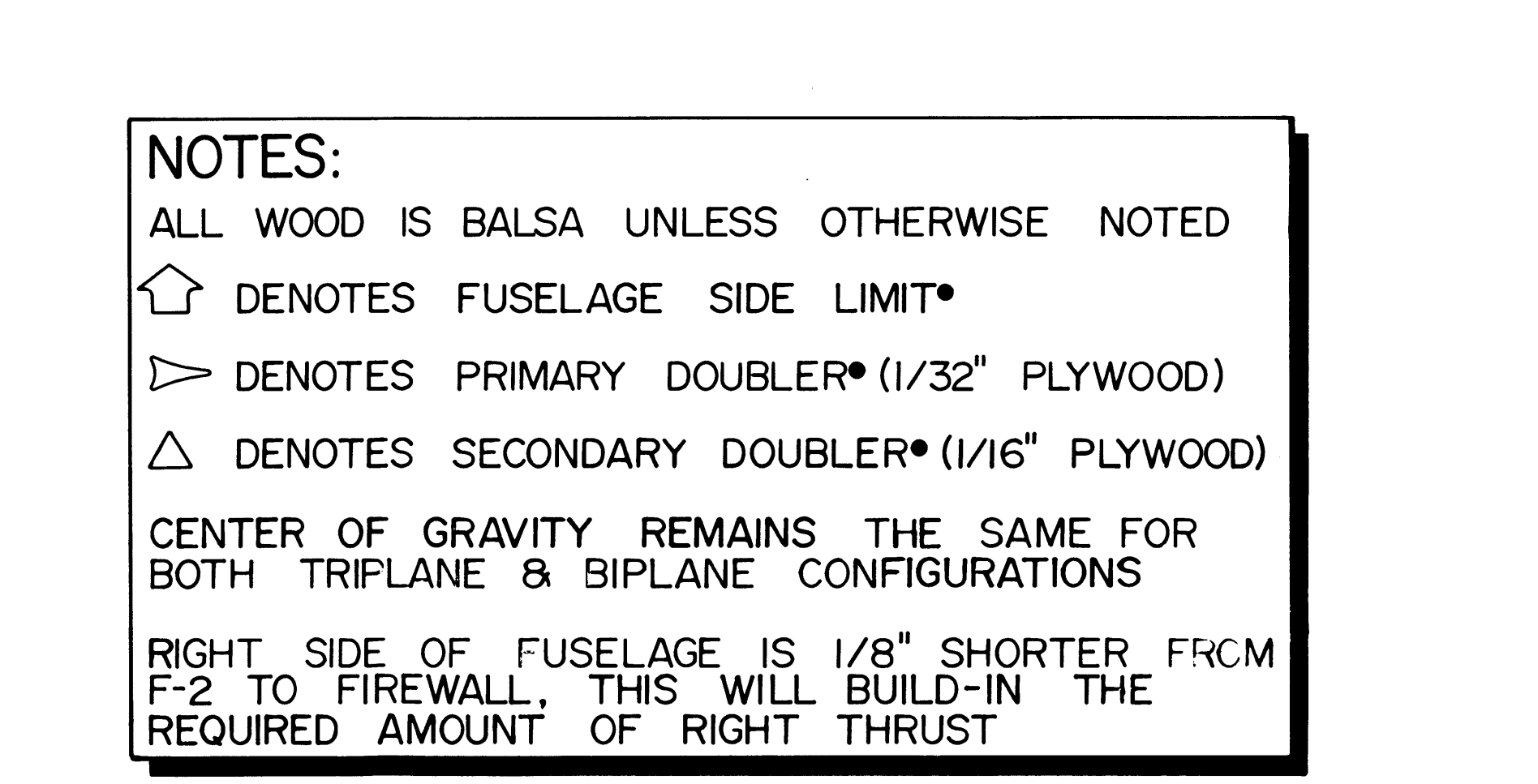
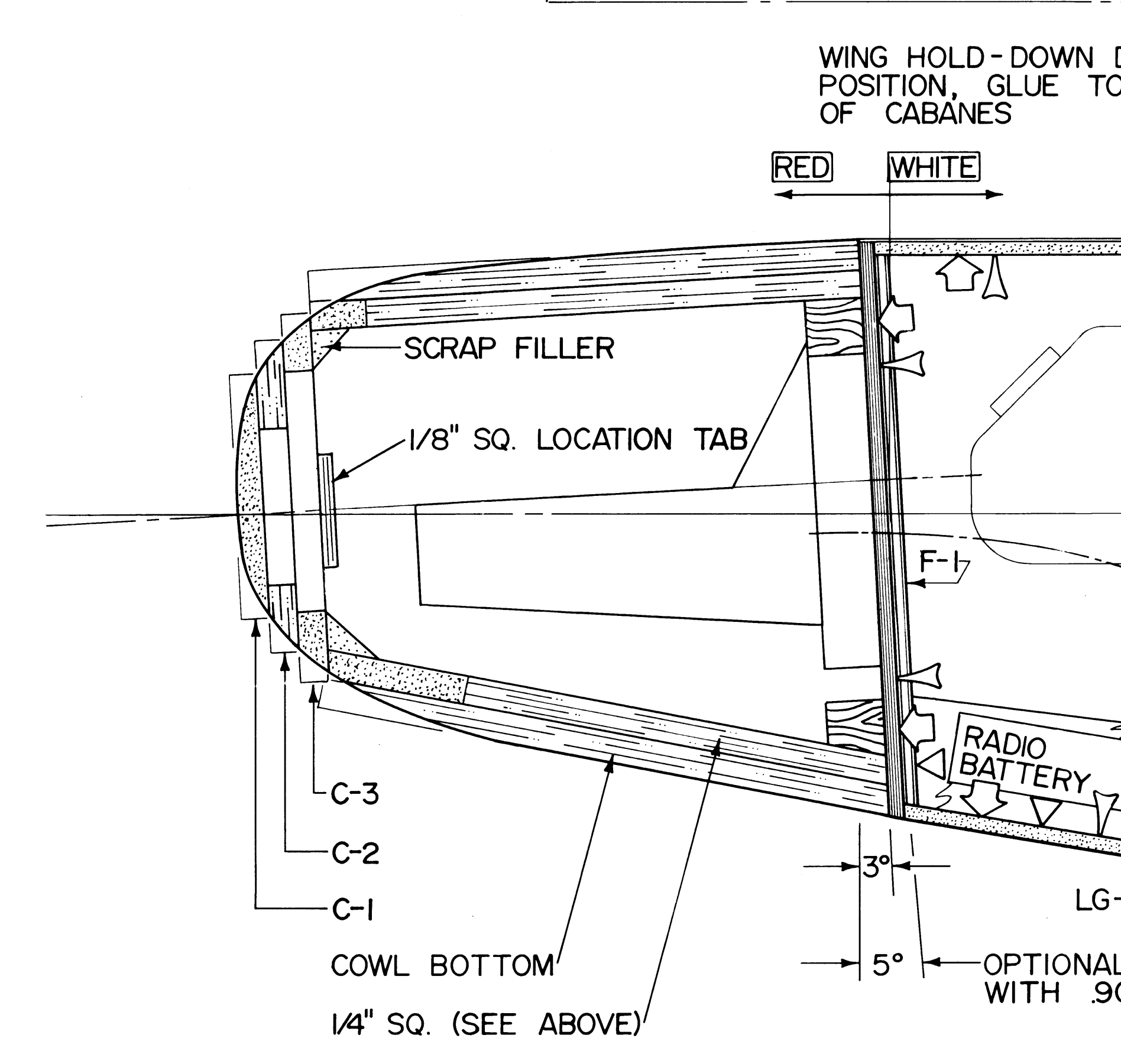
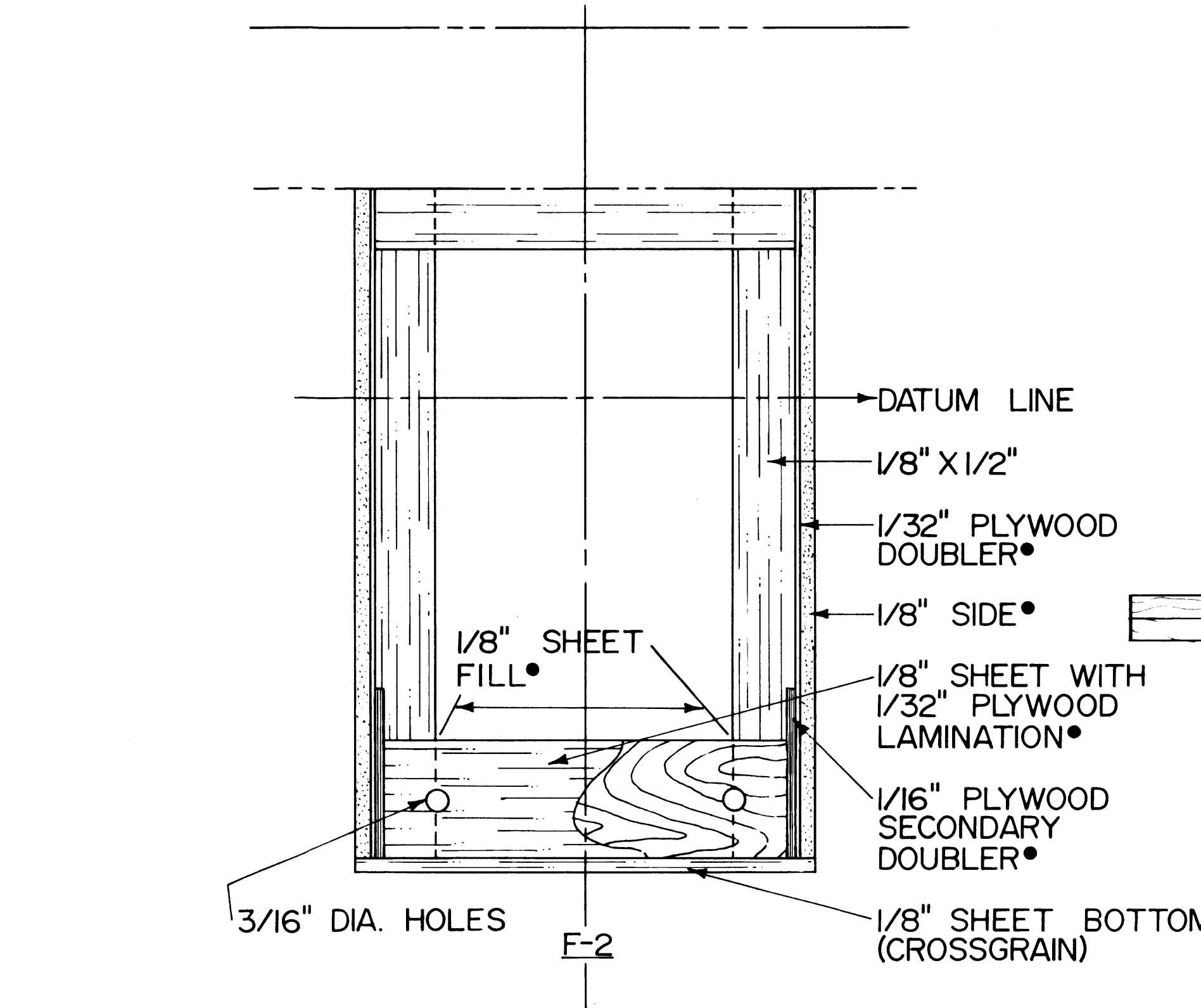
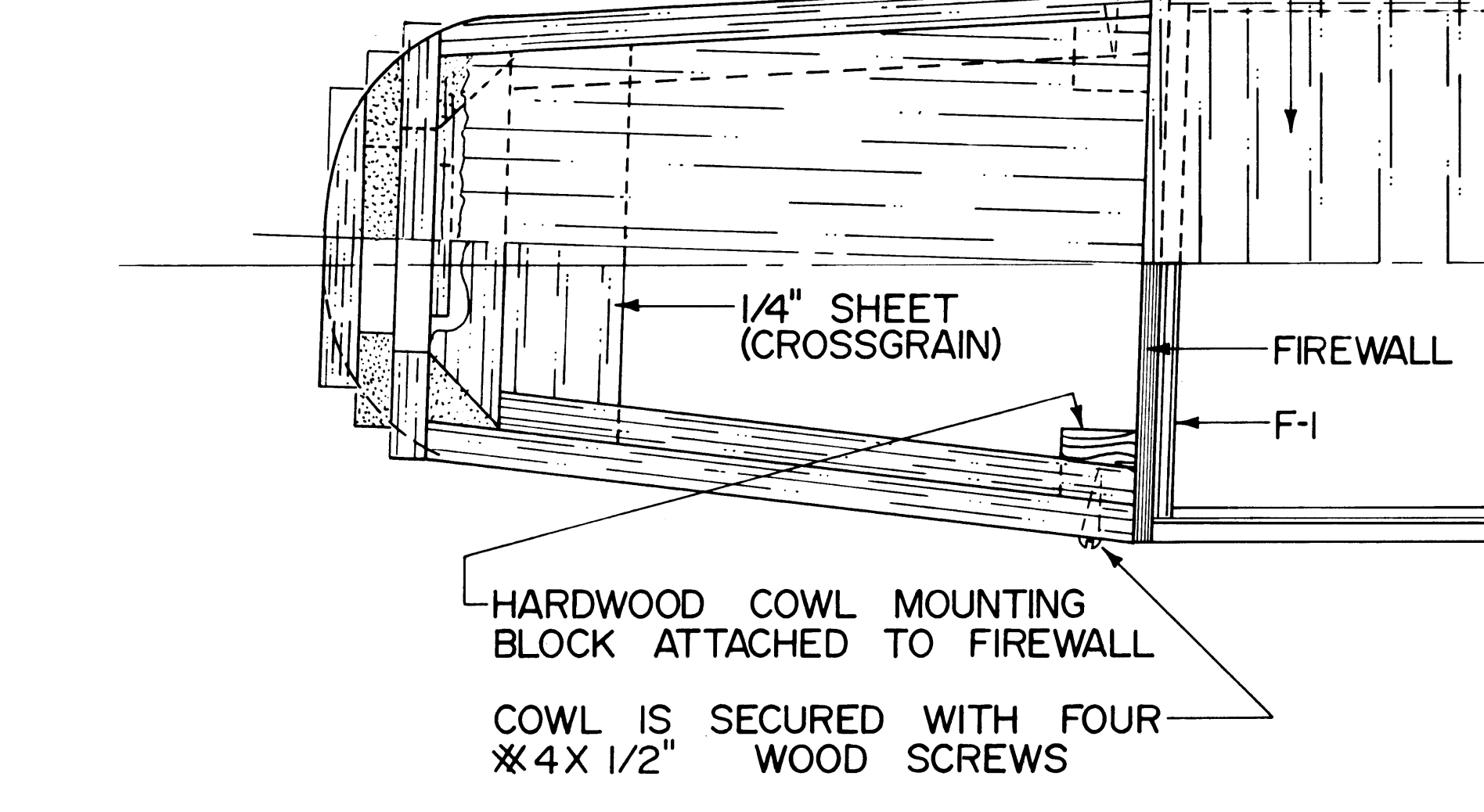
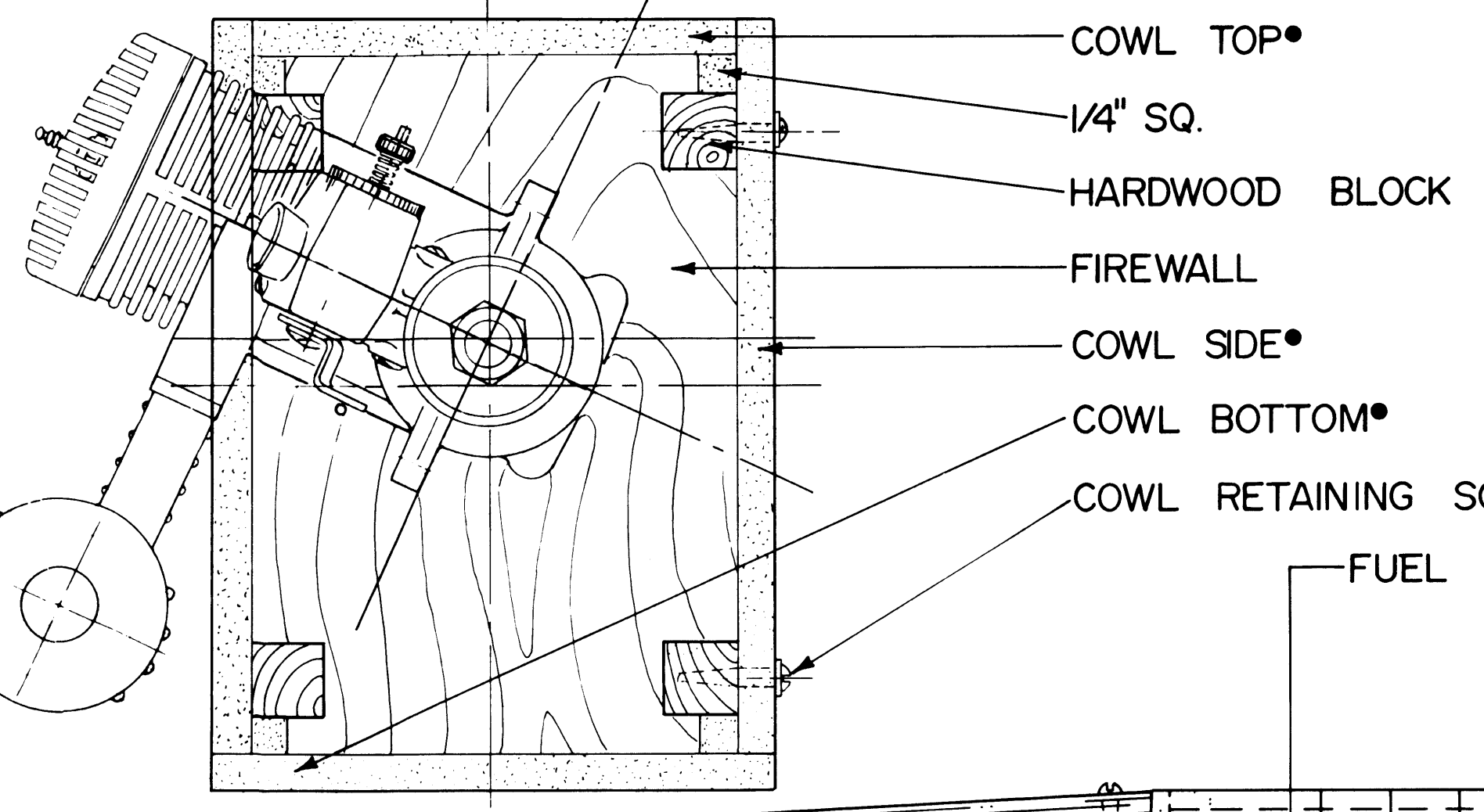
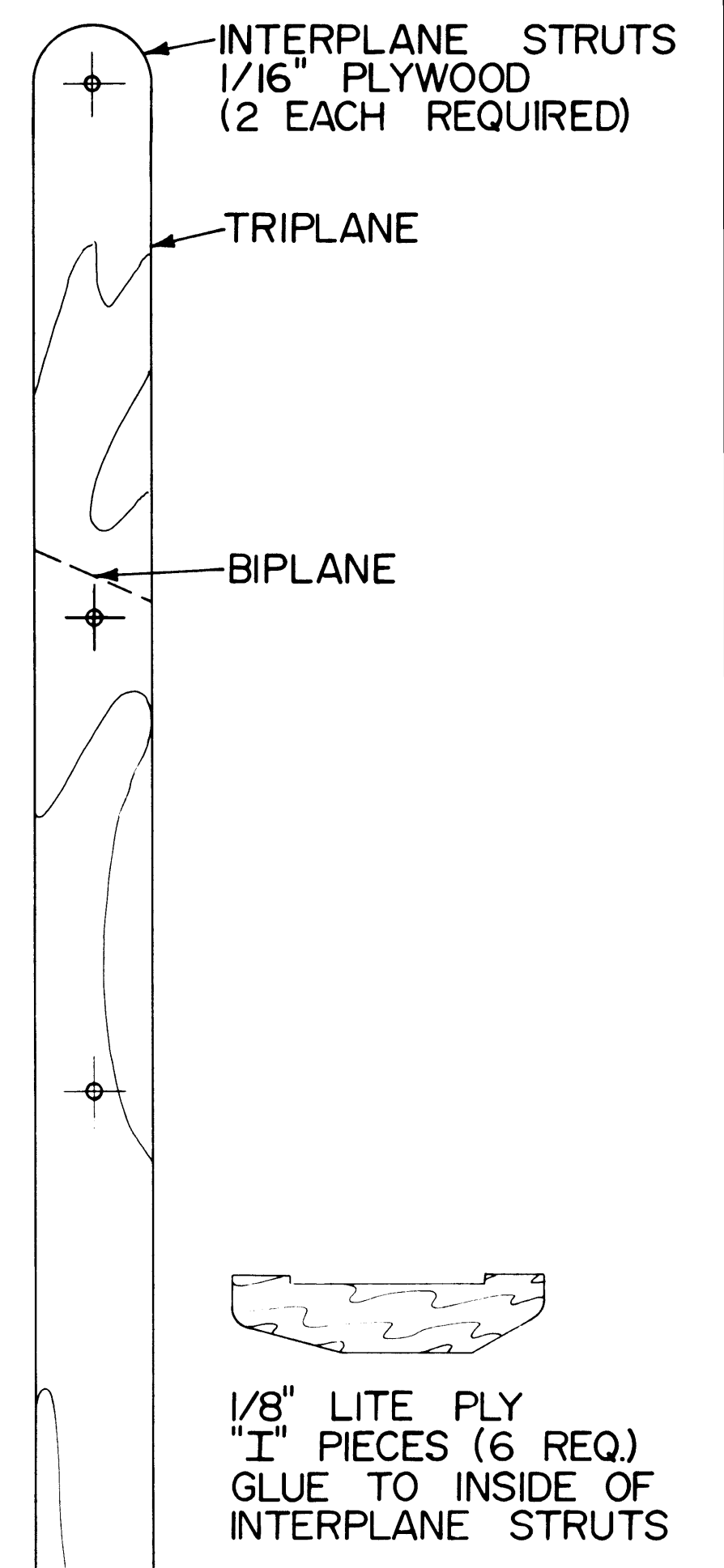
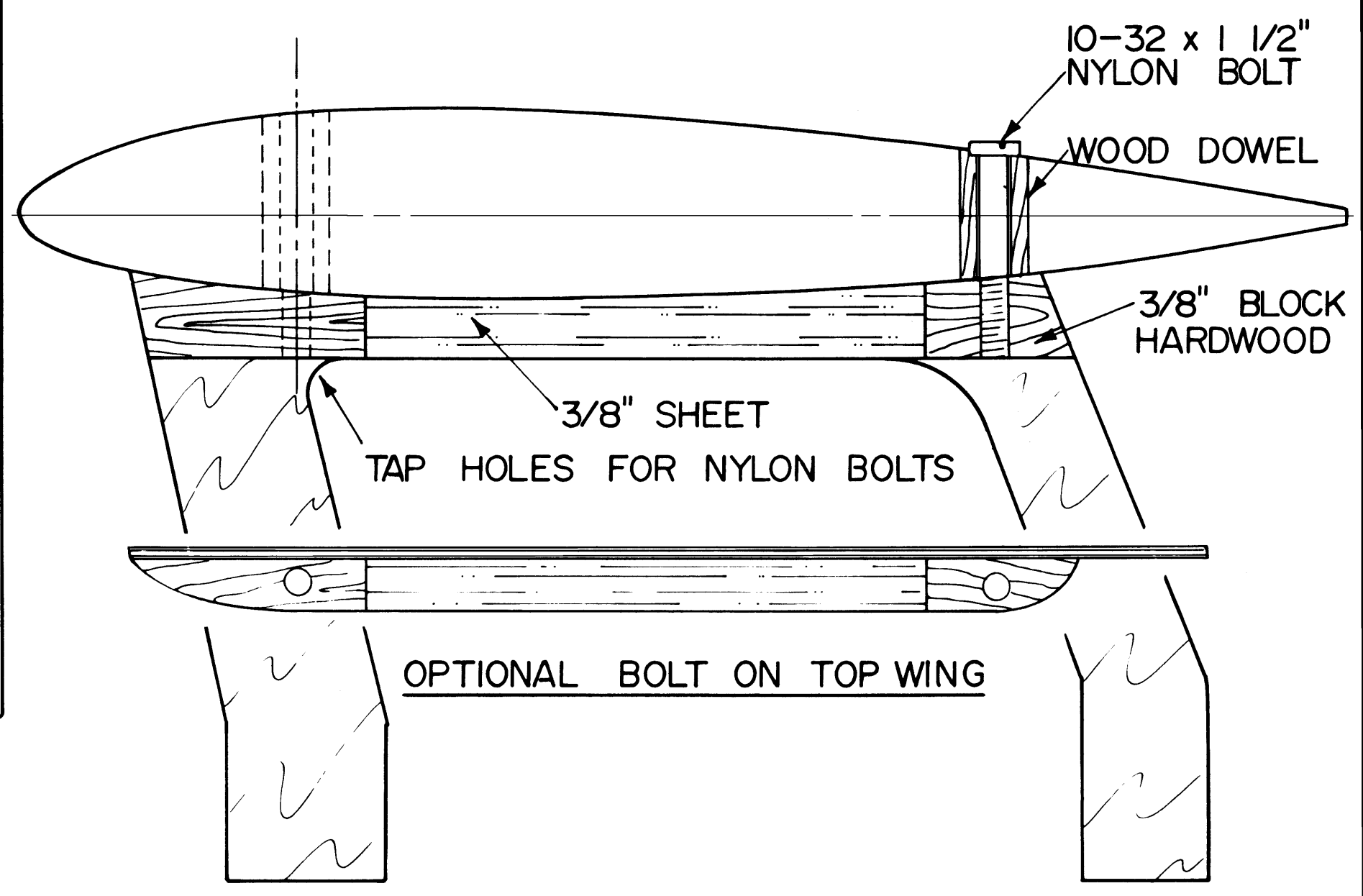

**NOTES:**  
 ALL WOOD IS BALSA UNLESS OTHERWISE NOTED  
 ◁ DENOTES FUSELAGE SIDE LIMIT\*  
 ▷ DENOTES PRIMARY DOUBLER\* (1/32" PLYWOOD)  
 △ DENOTES SECONDARY DOUBLER\* (1/16" PLYWOOD)  
 CENTER OF GRAVITY REMAINS THE SAME FOR BOTH TRIPLANE & BIPLANE CONFIGURATIONS  
 RIGHT SIDE OF FUSELAGE IS 1/8" SHORTER FROM F-2 TO FIREWALL. THIS WILL BUILD-IN THE REQUIRED AMOUNT OF RIGHT THRUST

**NOTES:**  
 ● DENOTES PATTERN AVAILABLE ON PLANS IN ANOTHER AREA

CONTROL SURFACE	DIRECTION	THROWS - RADIO USED IN PROTOTYPE	
		LOW EXPONENTIAL RATE	HIGH EXPONENTIAL RATE
AILERON	UP	3/16"	3/16"
	DOWN	9/16"	9/16"
ELEVATOR	UP	3/8"	3/8"
	DOWN	3/8"	3/8"
RUDDER	LEFT	1-1/2"	2-1/2"
	RIGHT	NOT AVAIL.	NOT AVAIL.

**TRIPE-A-BIPE**  
 AN INTERCHANGEABLE BIPLANE/TRIPLANE DESIGN

DESIGNED BY: HOWARD "Spinner" SCHUTT  
 PLANS BY: DAVID VAUGHN

SHEET 1 OF 3

0 1 2 3 4 5 6

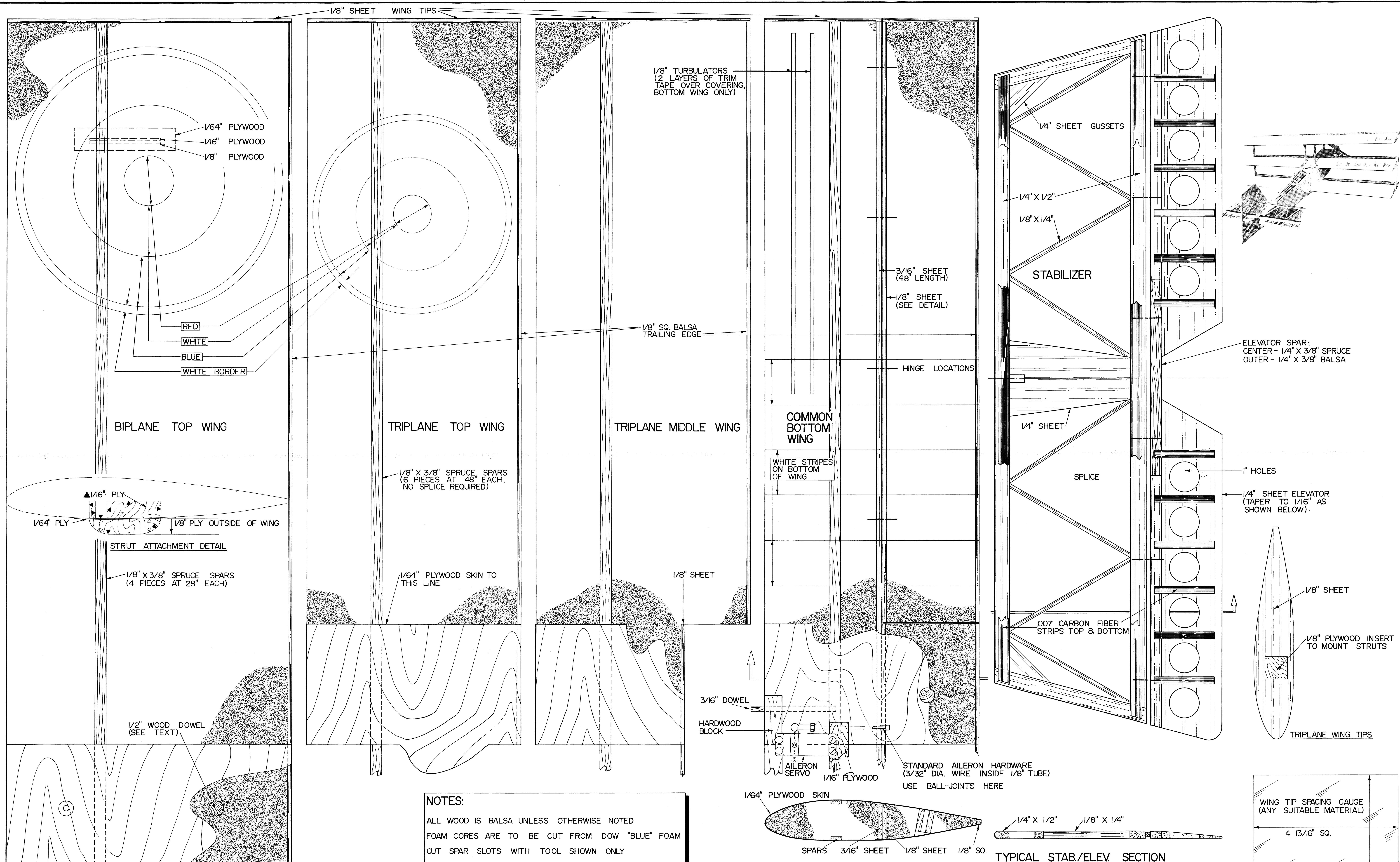

**NOTES:**

ALL WOOD IS Balsa UNLESS OTHERWISE NOTED

FOAM CORES ARE TO BE CUT FROM DOW "BLUE" FOAM

CUT SPAR SLOTS WITH TOOL SHOWN ONLY

COVER WINGS WITH LOW HEAT FILM

AILERON HINGES SHOULD BE OF 1/4 SCALE VARIETY

**NOTE:**  
NO DIHEDRAL  
ALL WINGS!

**WING CORE TEMPLATES** (DO NOT CUT SPAR SLOTS WITH BOW)

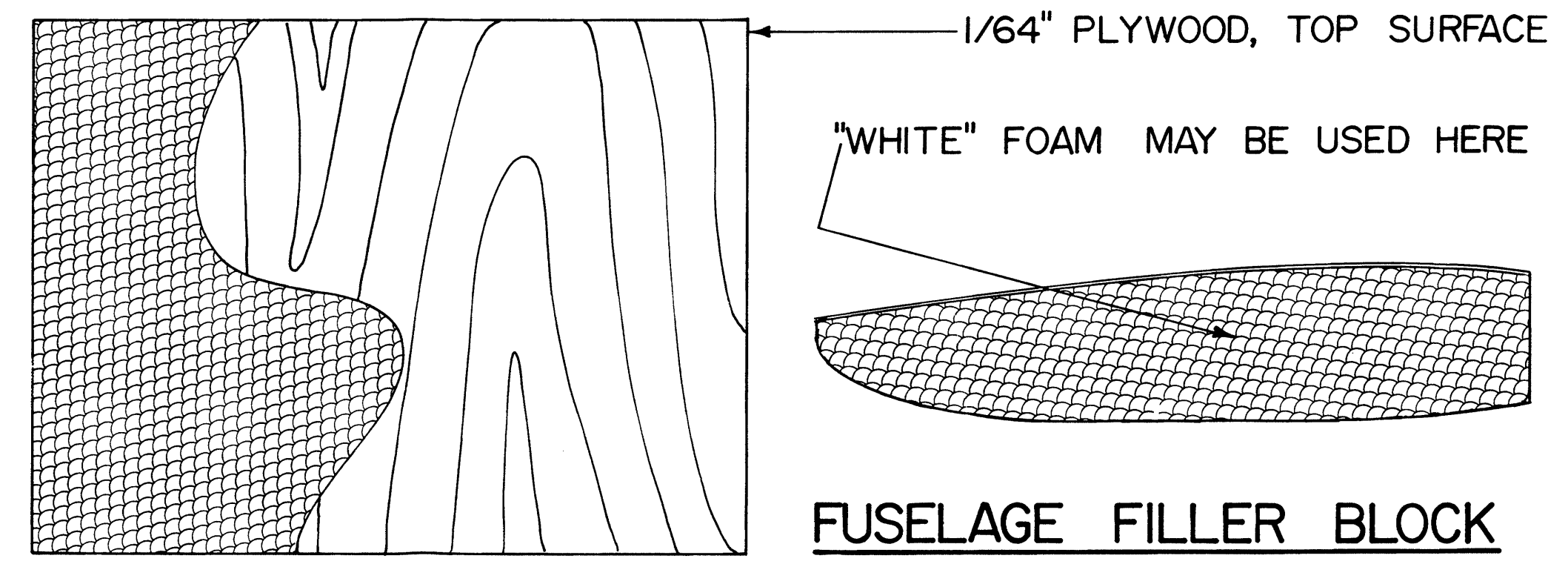
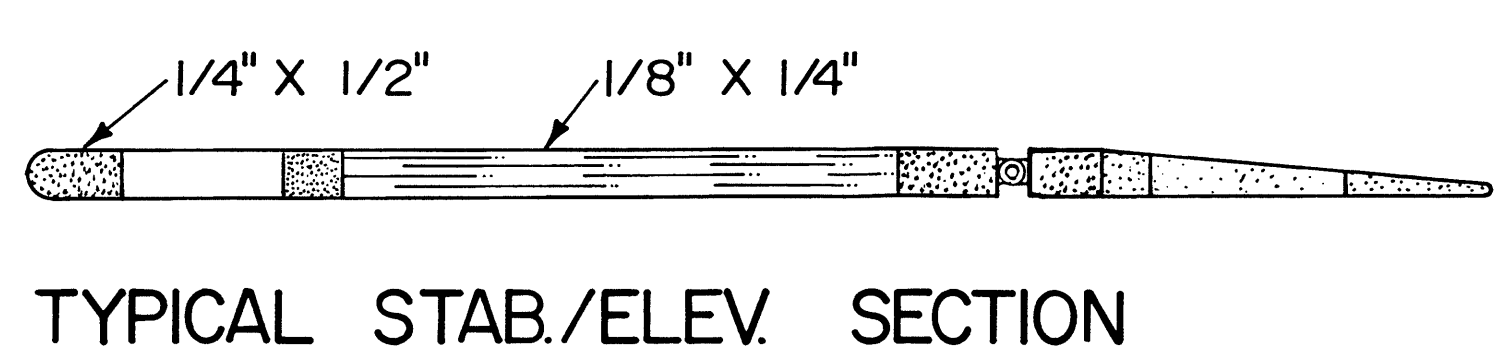
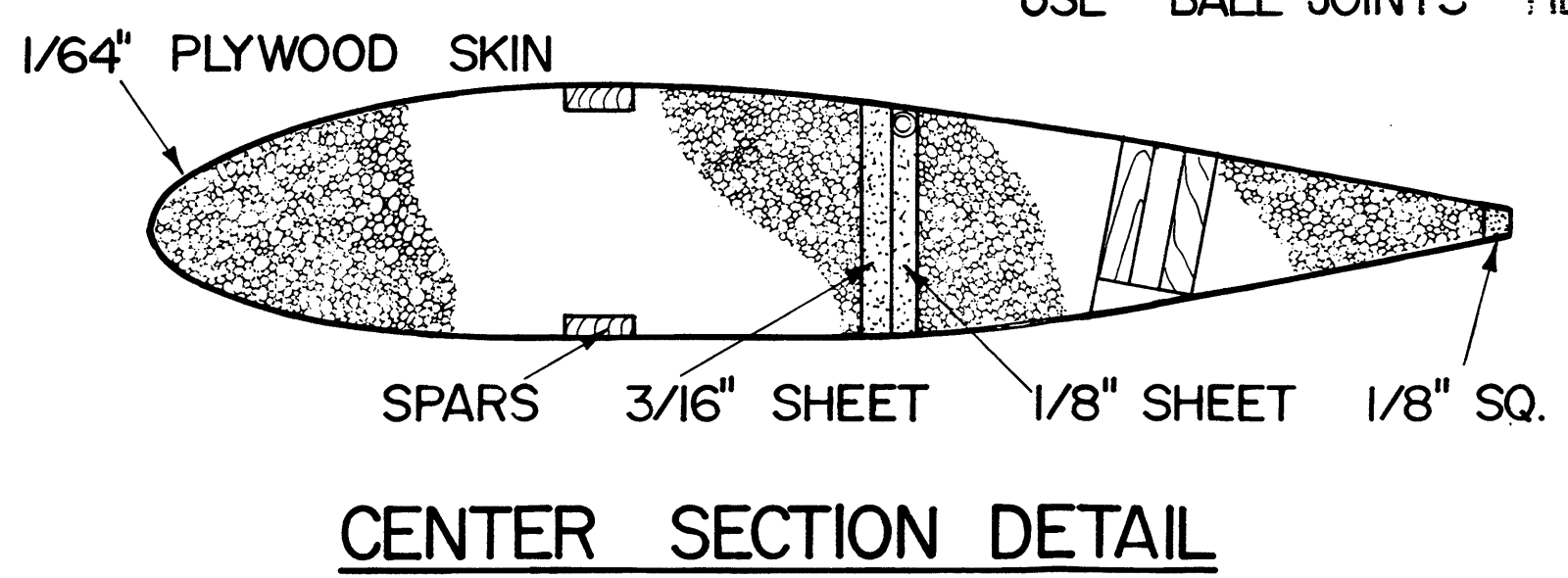
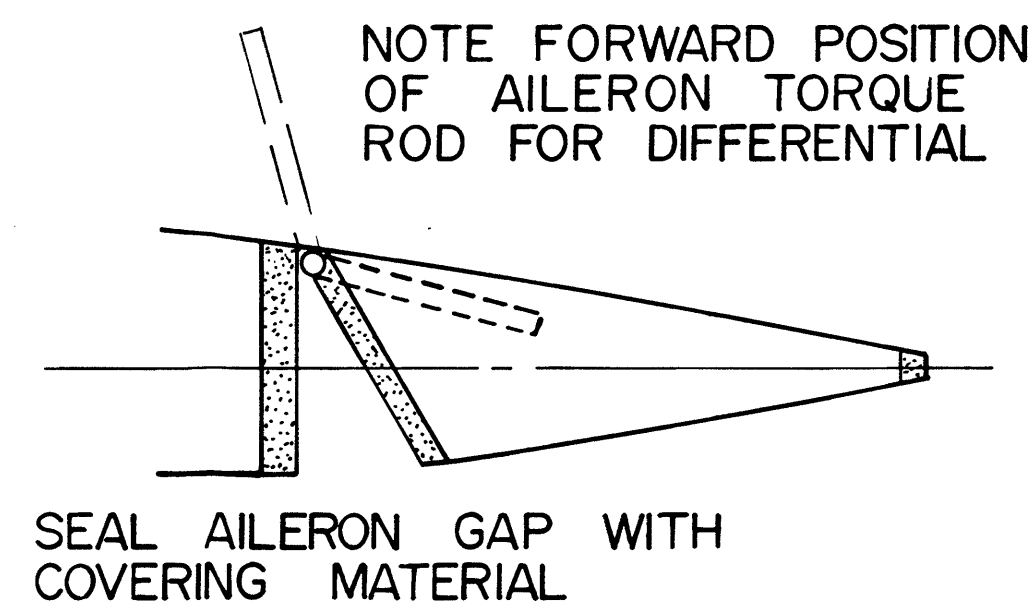
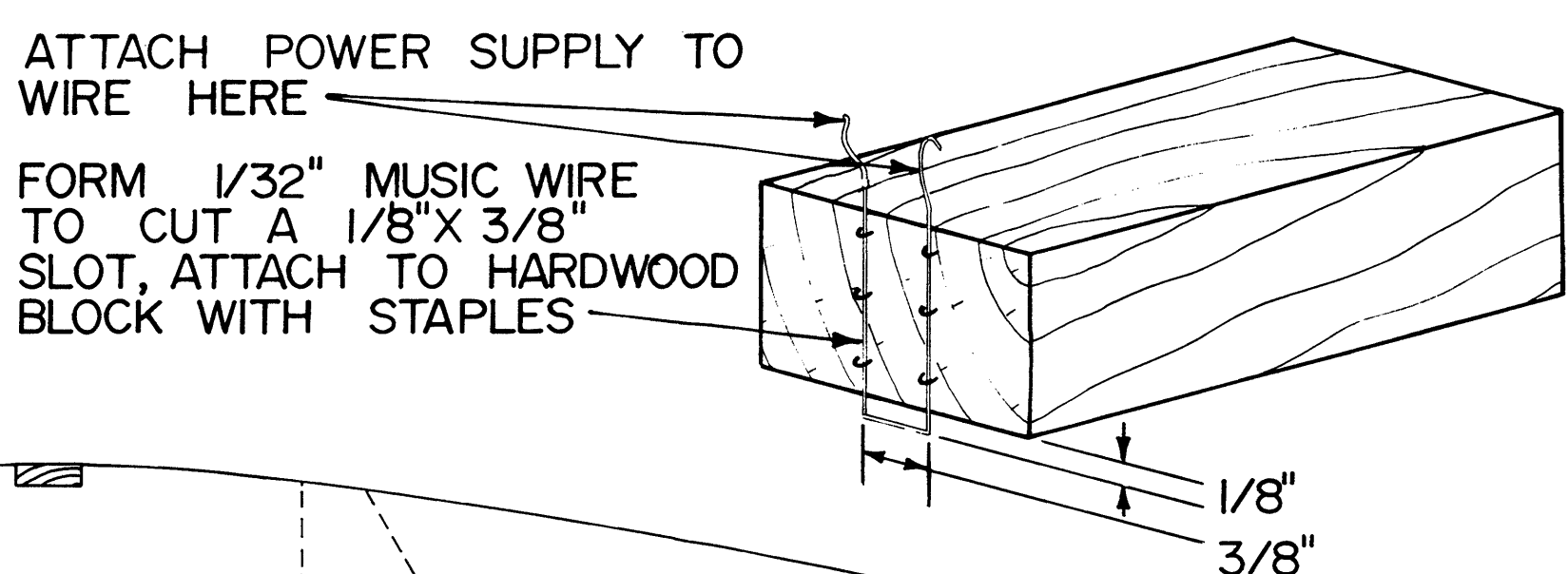
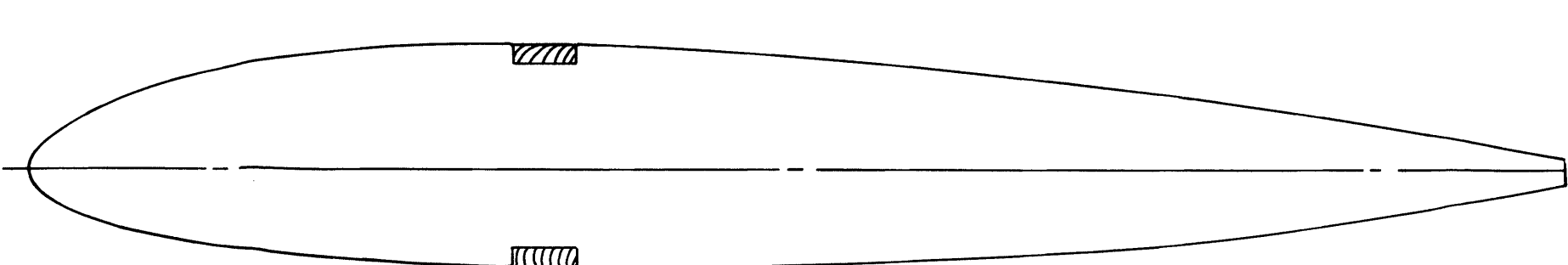

© RCM ALL COMMERCIAL RIGHTS RESERVED

**TRIPE-BIPE**

AN INTERCHANGEABLE BIPLANE / TRIPLANE DESIGN

DESIGNED BY: HOWARD "Spinner" SCHUTT | PLANS BY: DAVID VAUGHN

0 1/2 1 2 3 4 5 6

SHEET 2 OF 3

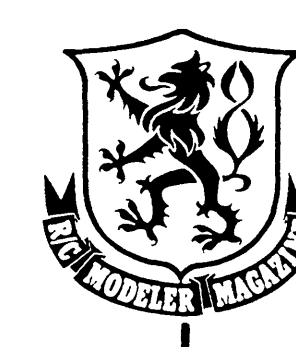
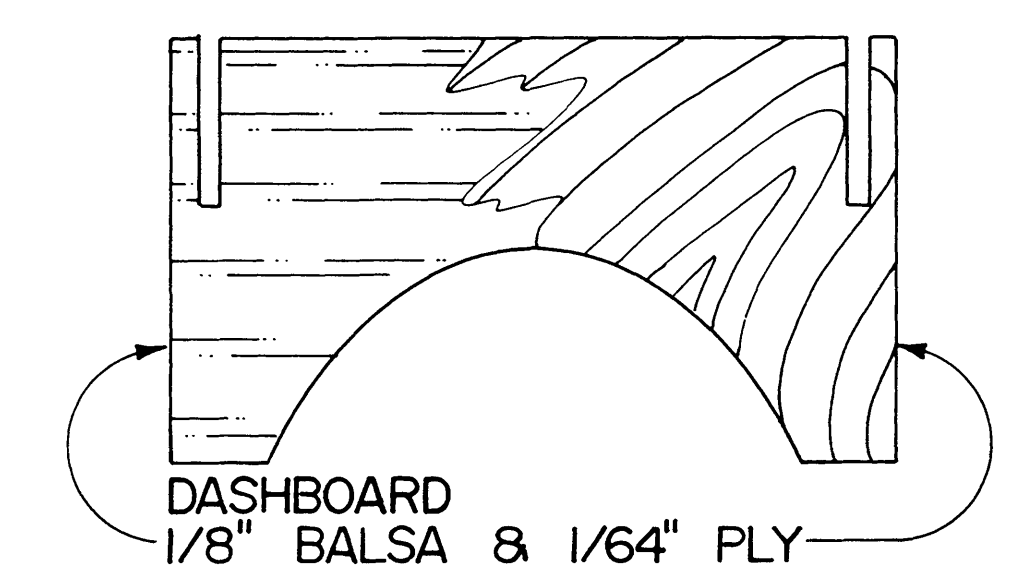
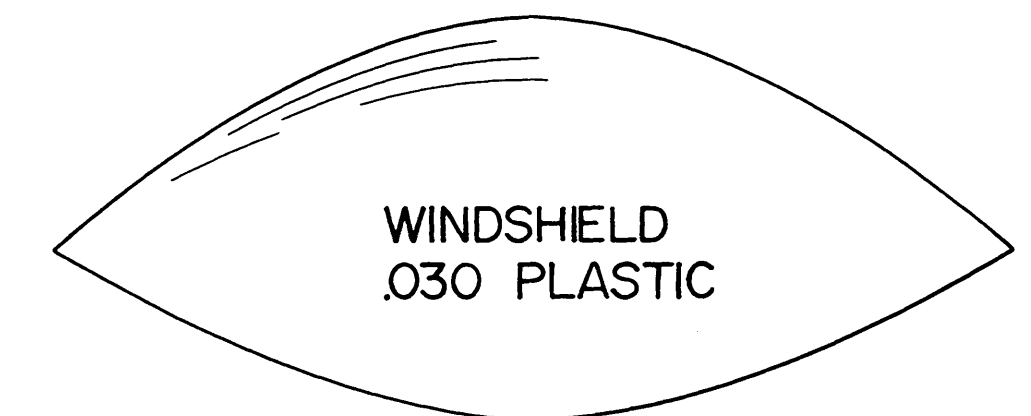
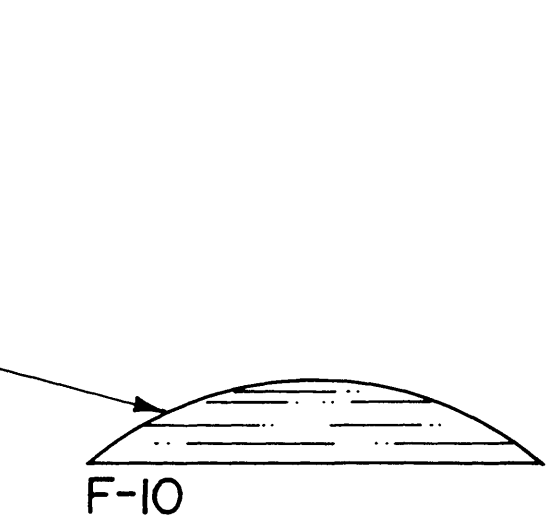
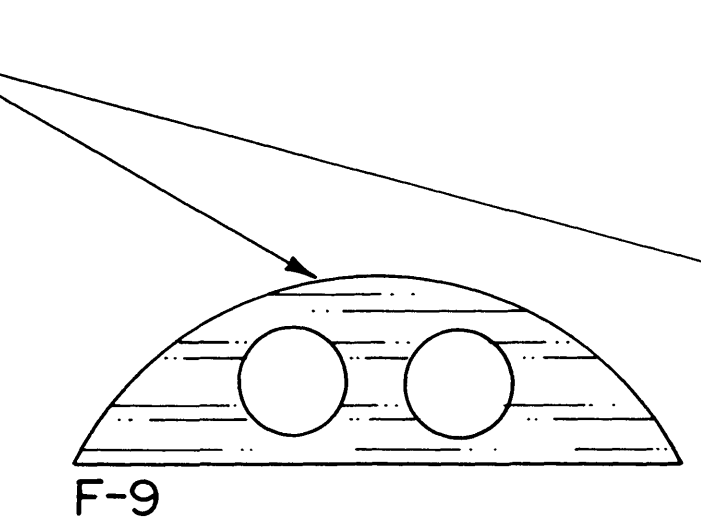
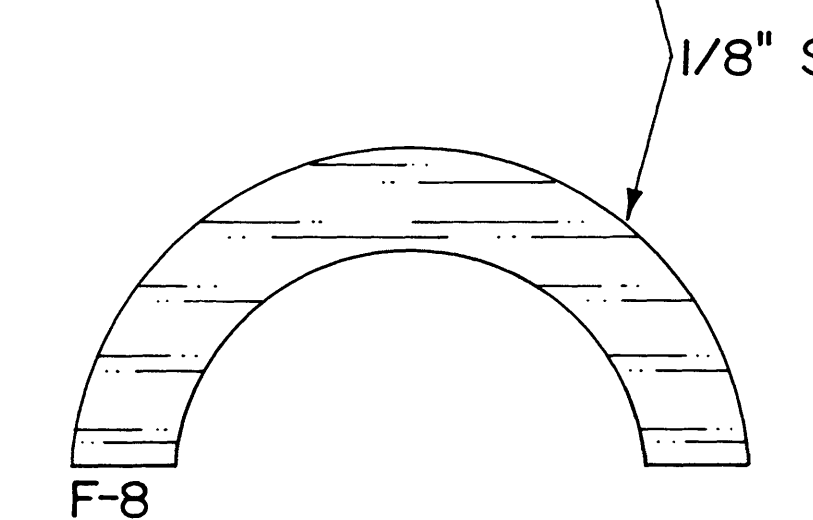
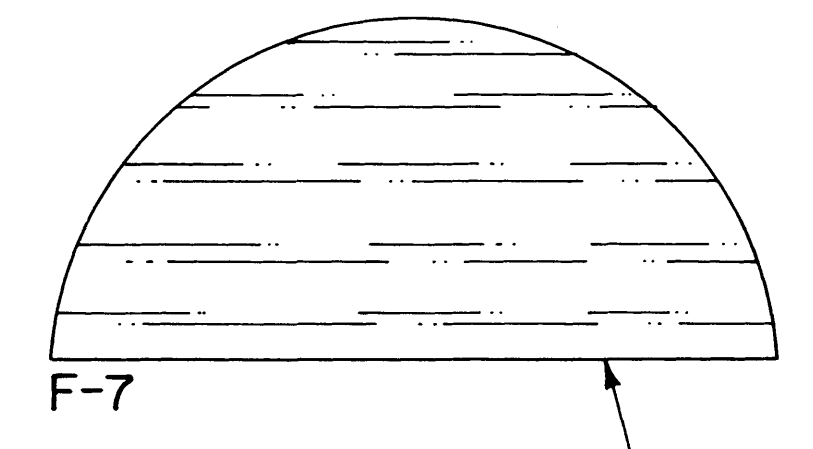
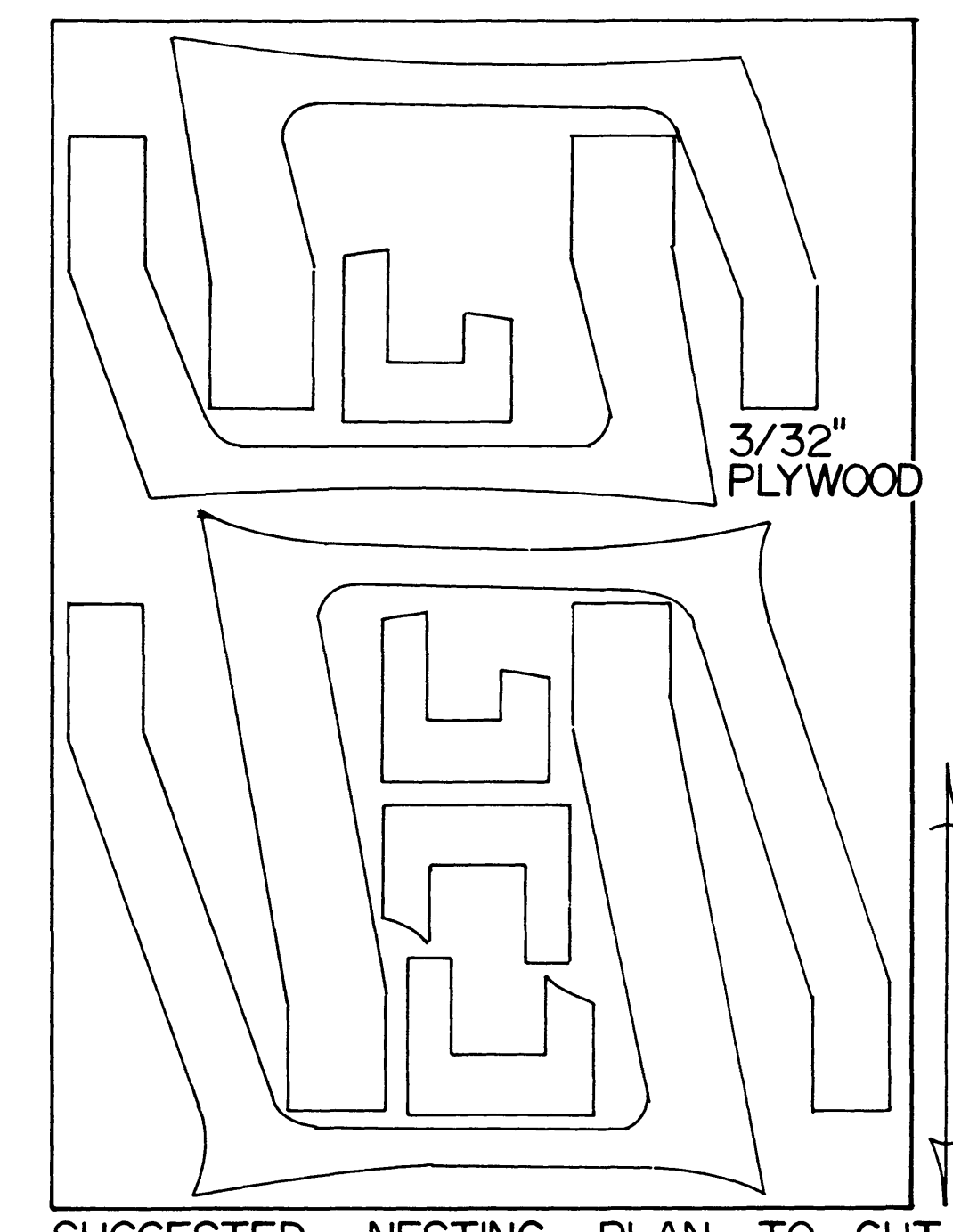
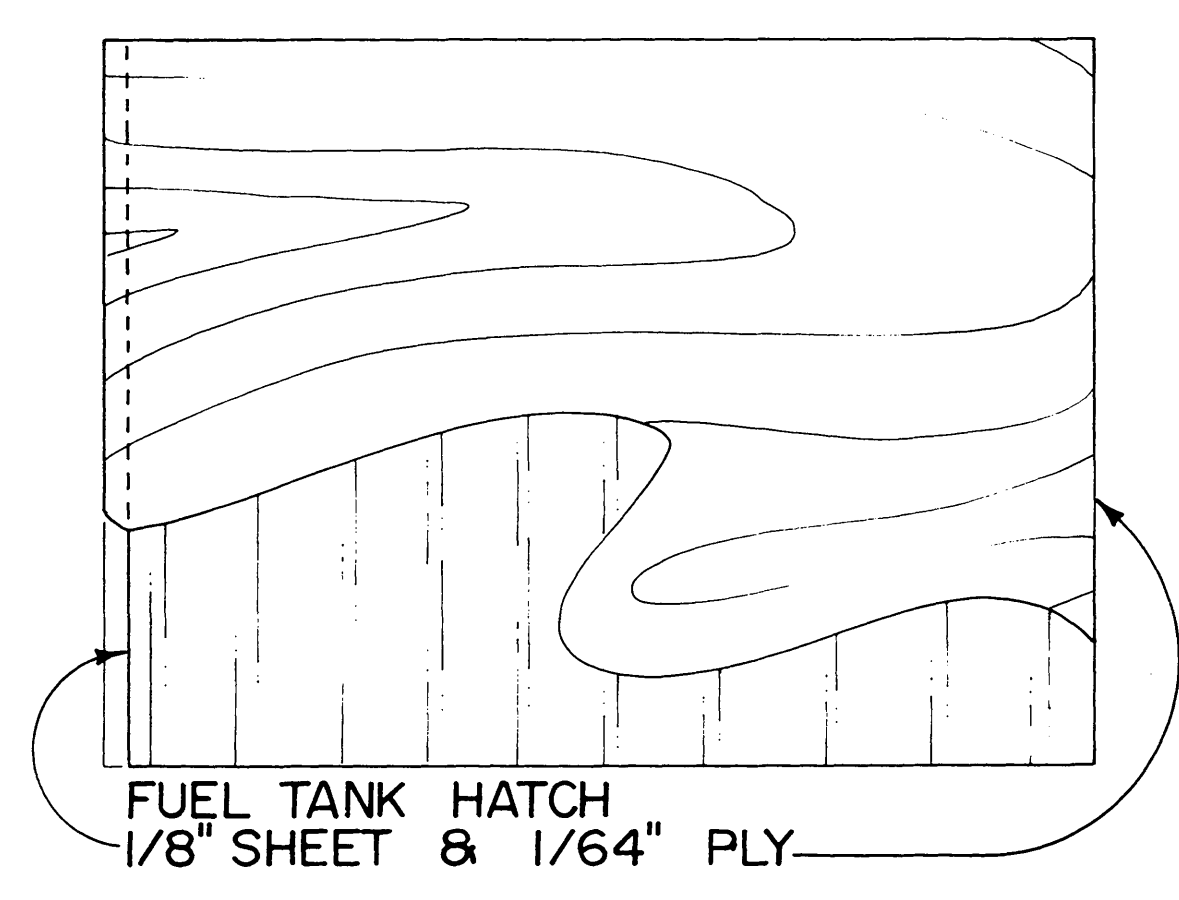
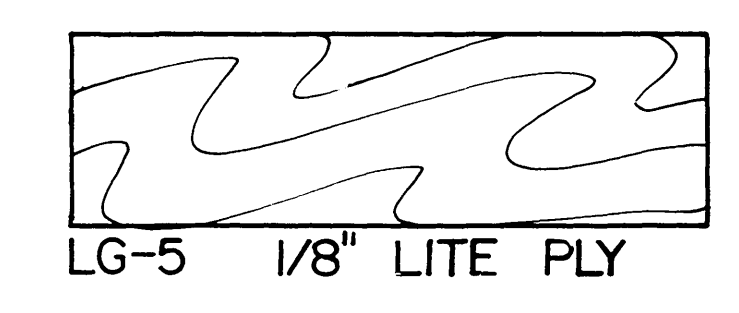
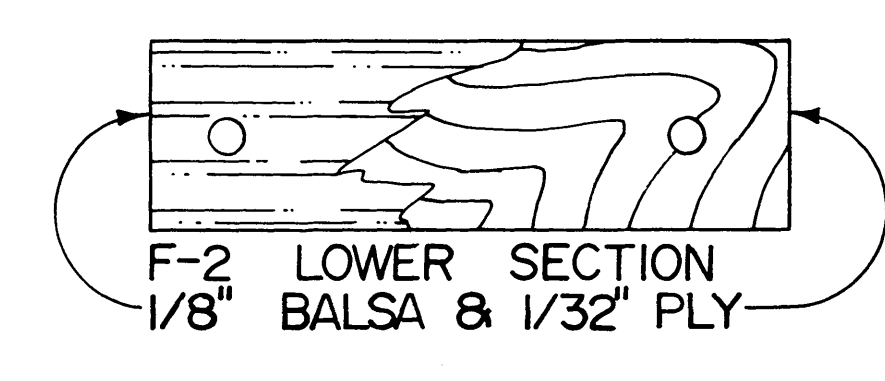
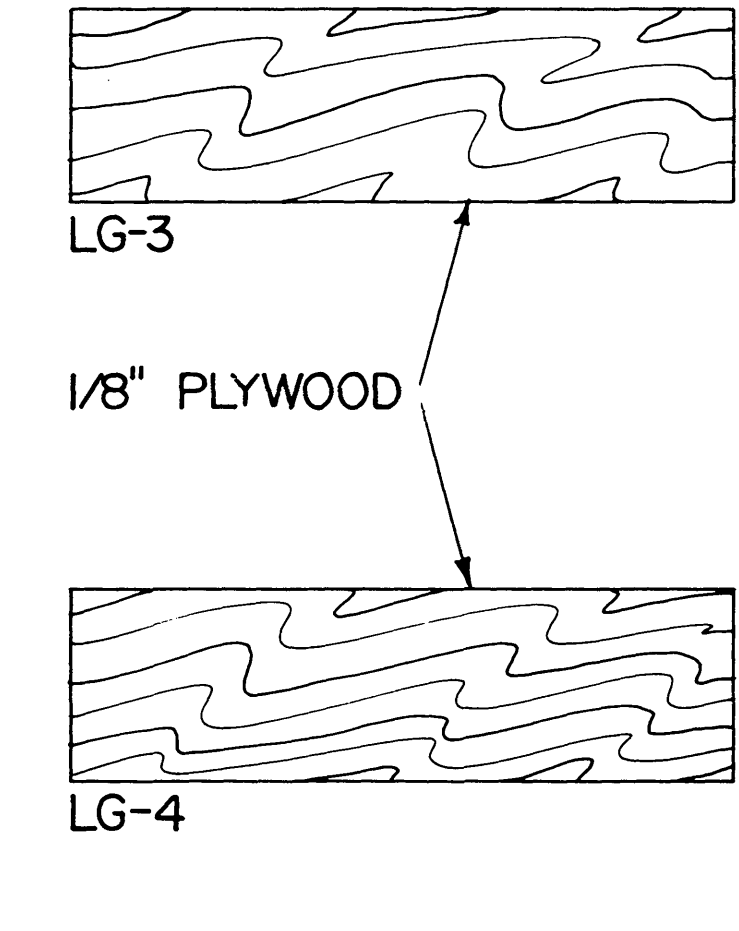
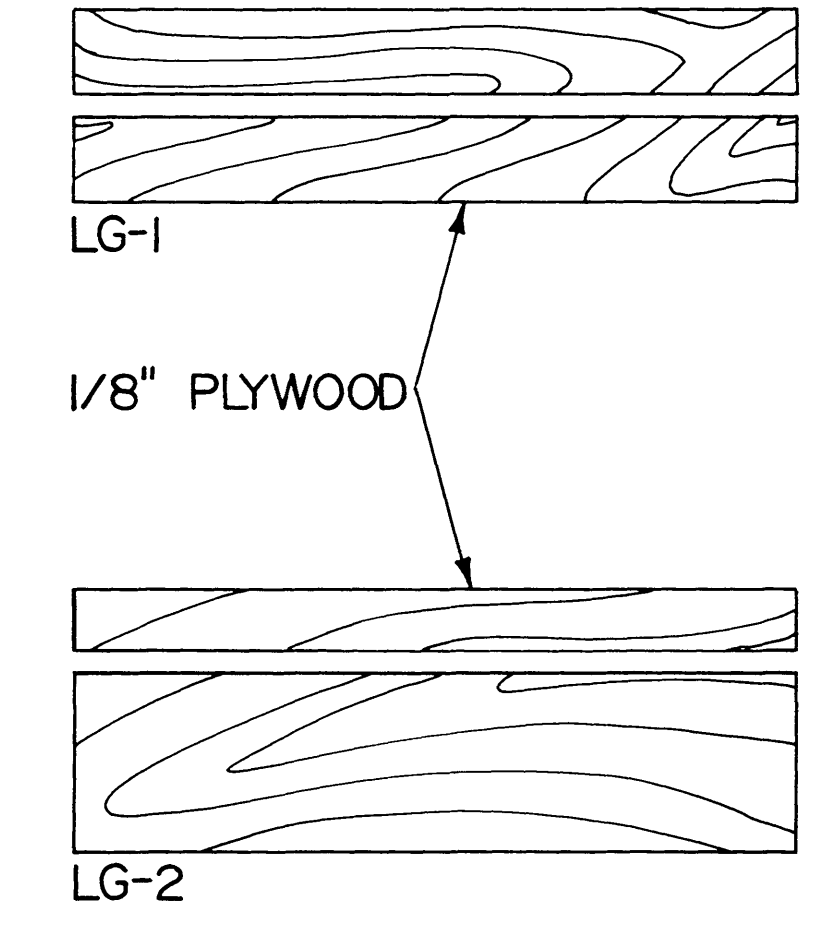
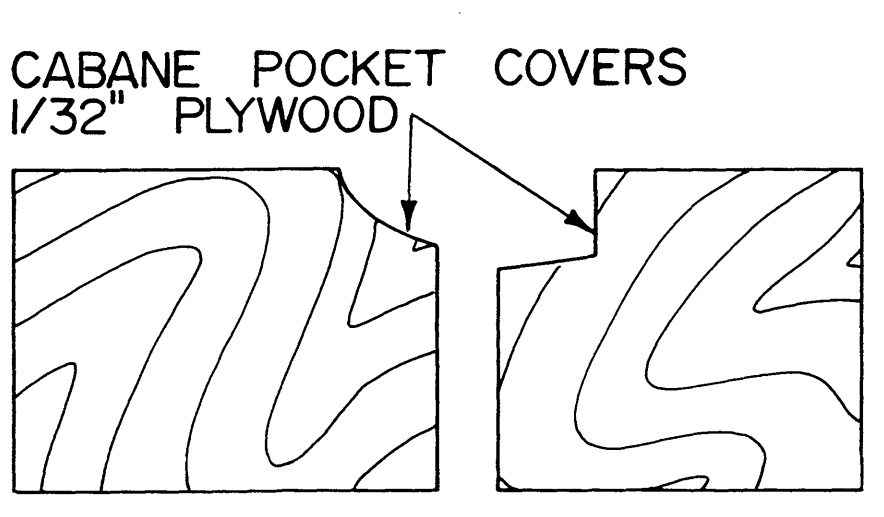
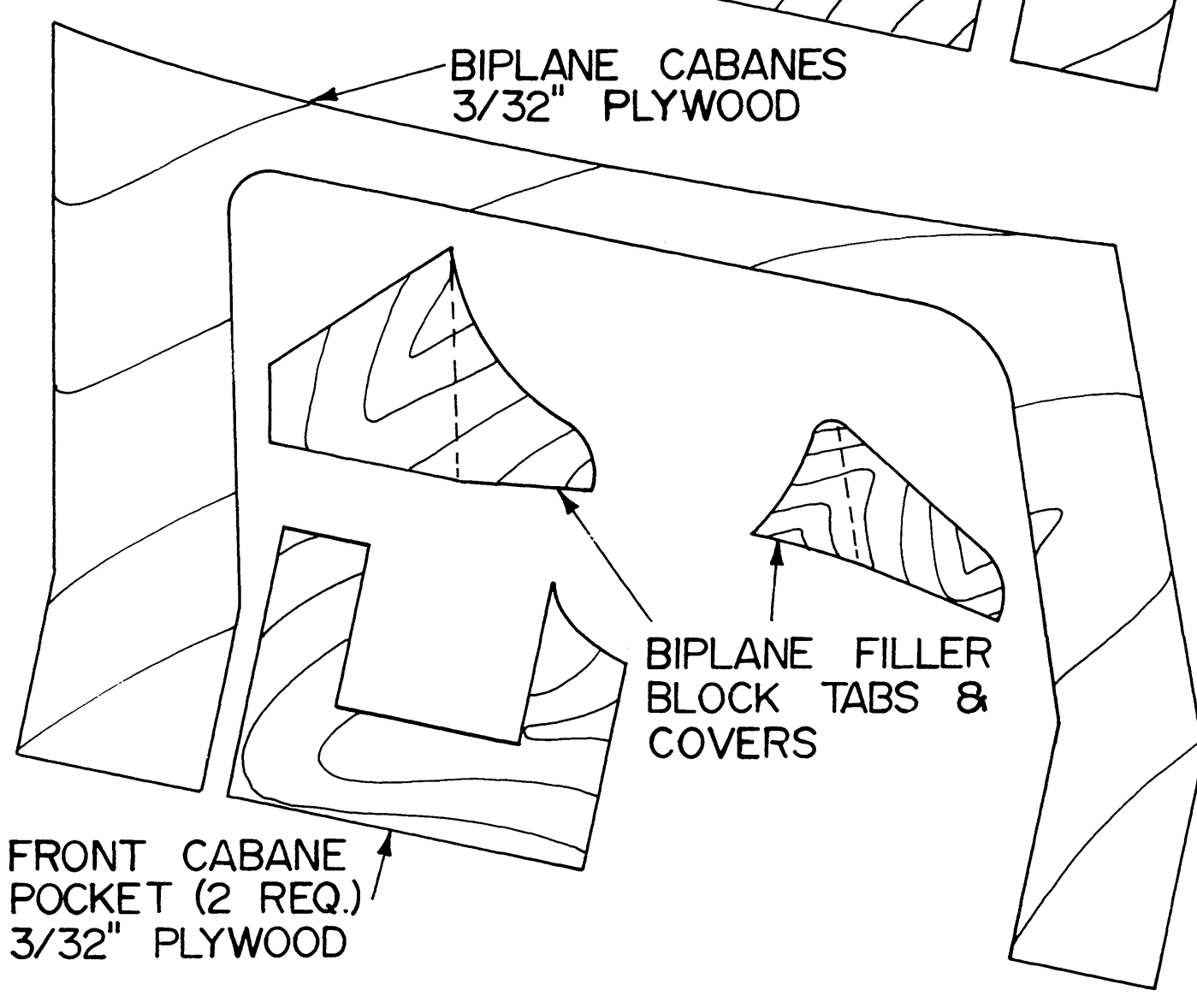
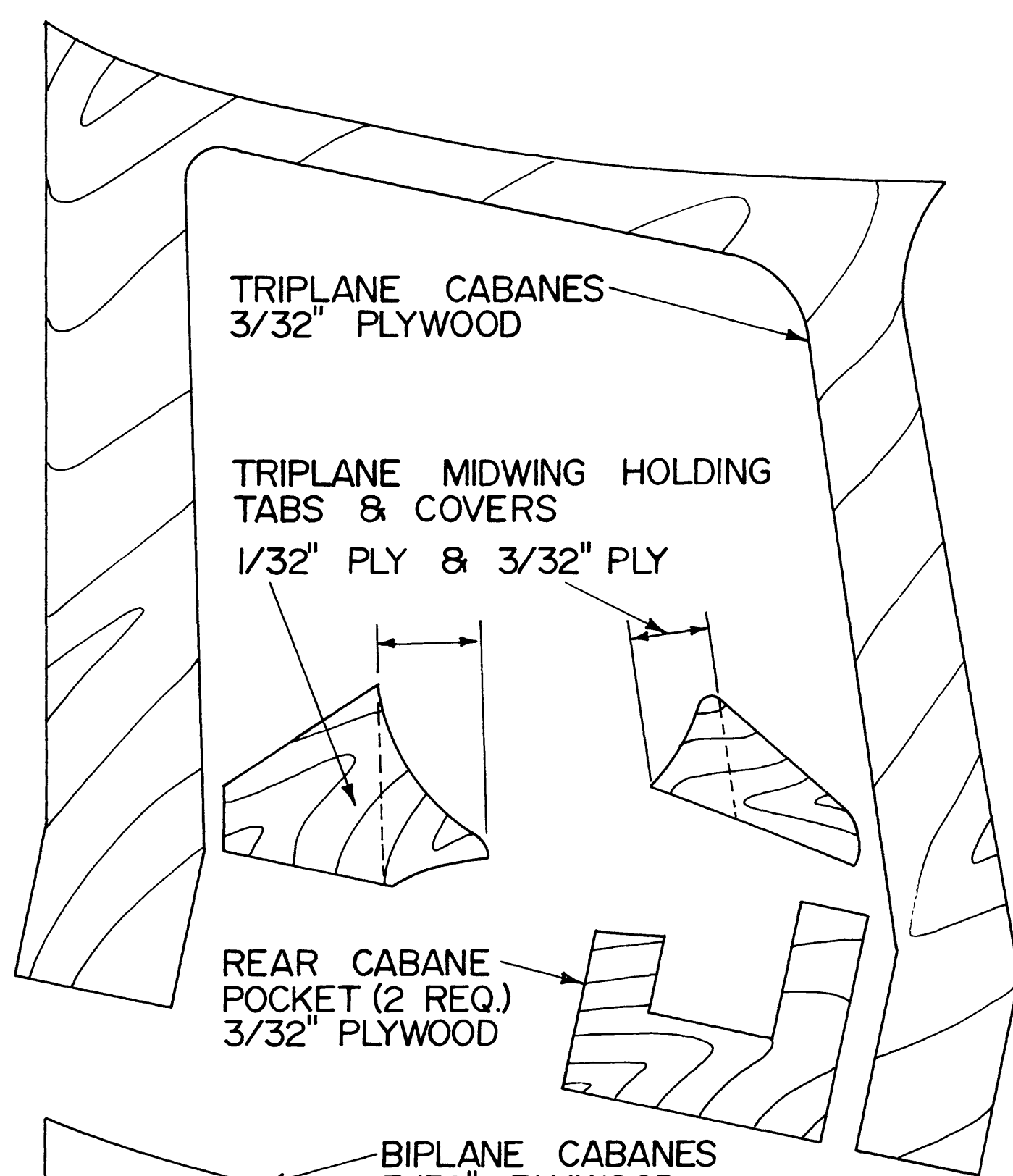
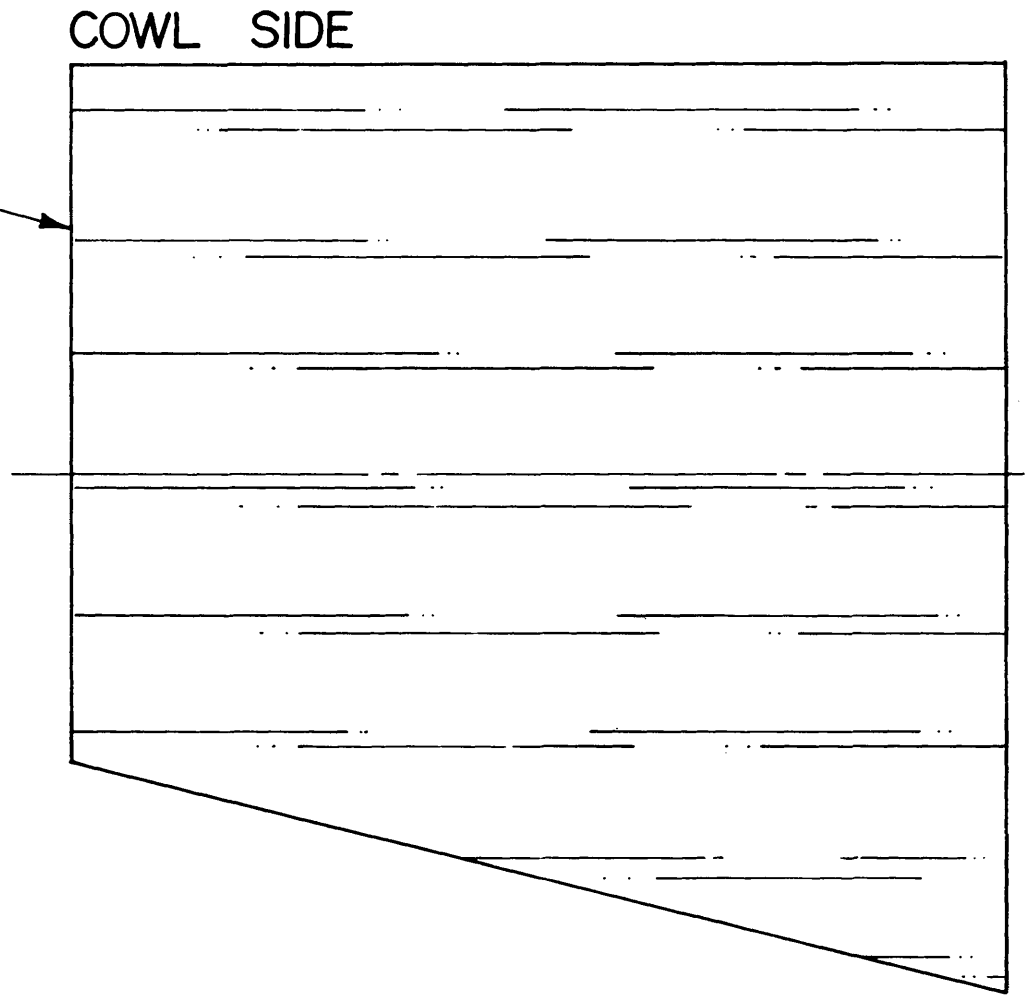
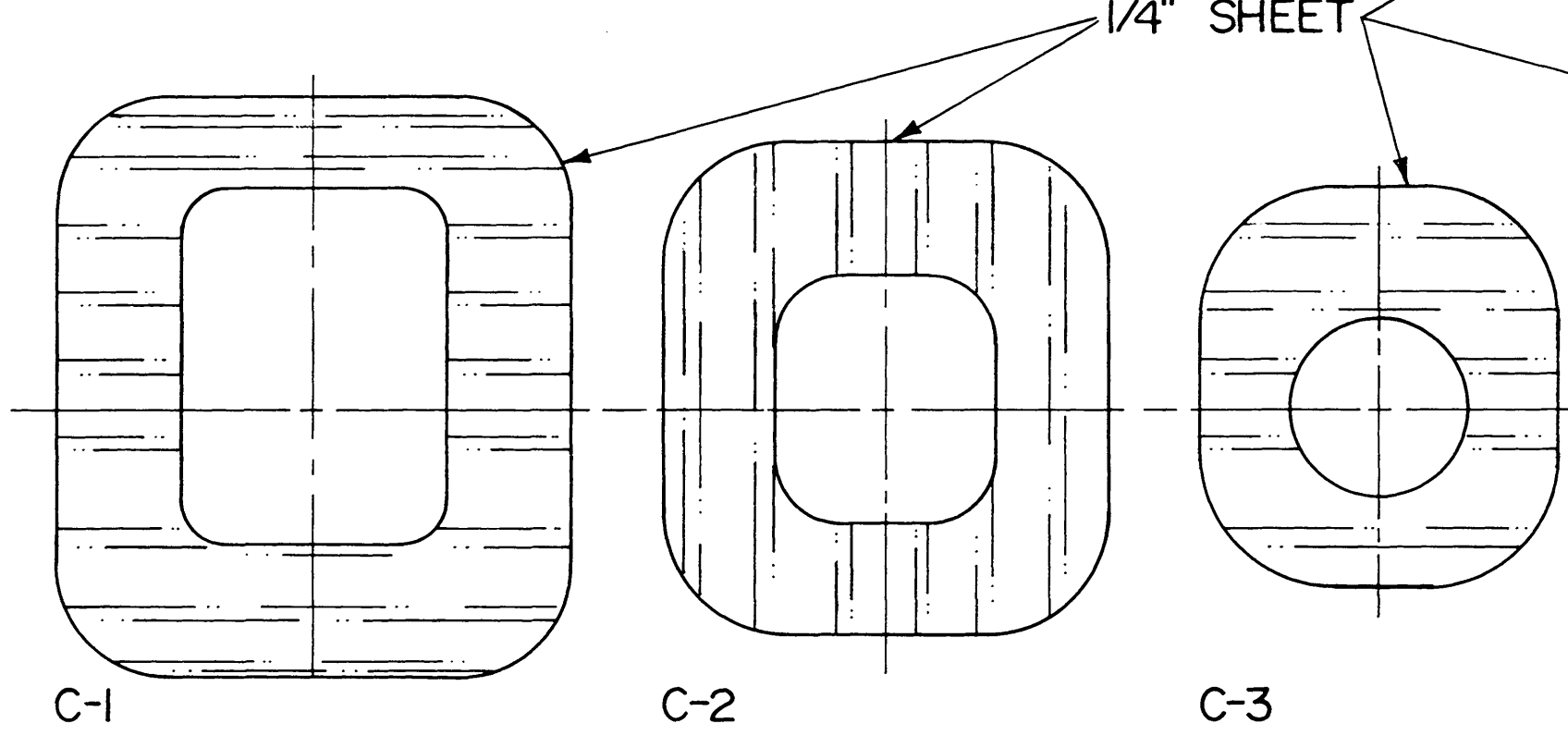
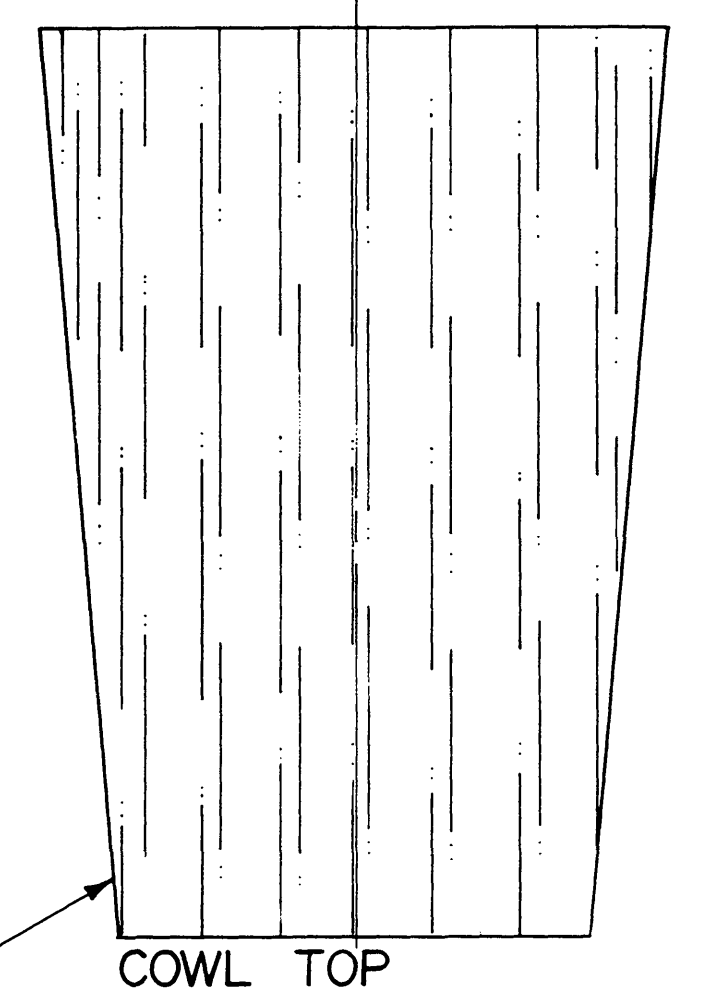
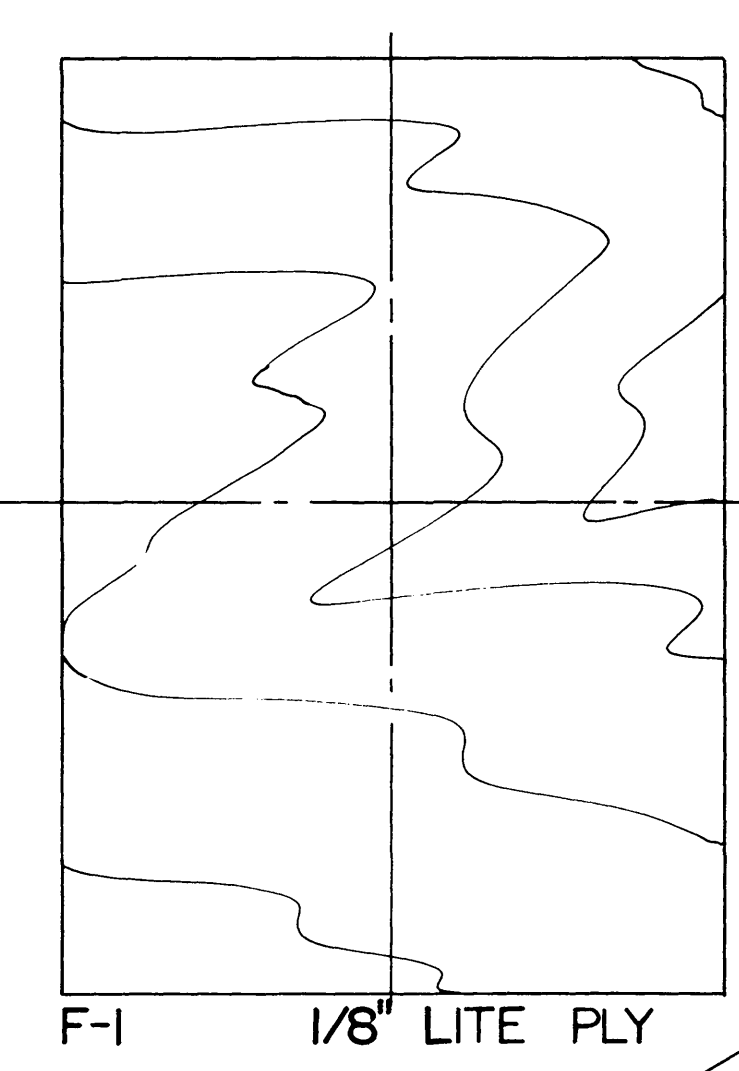
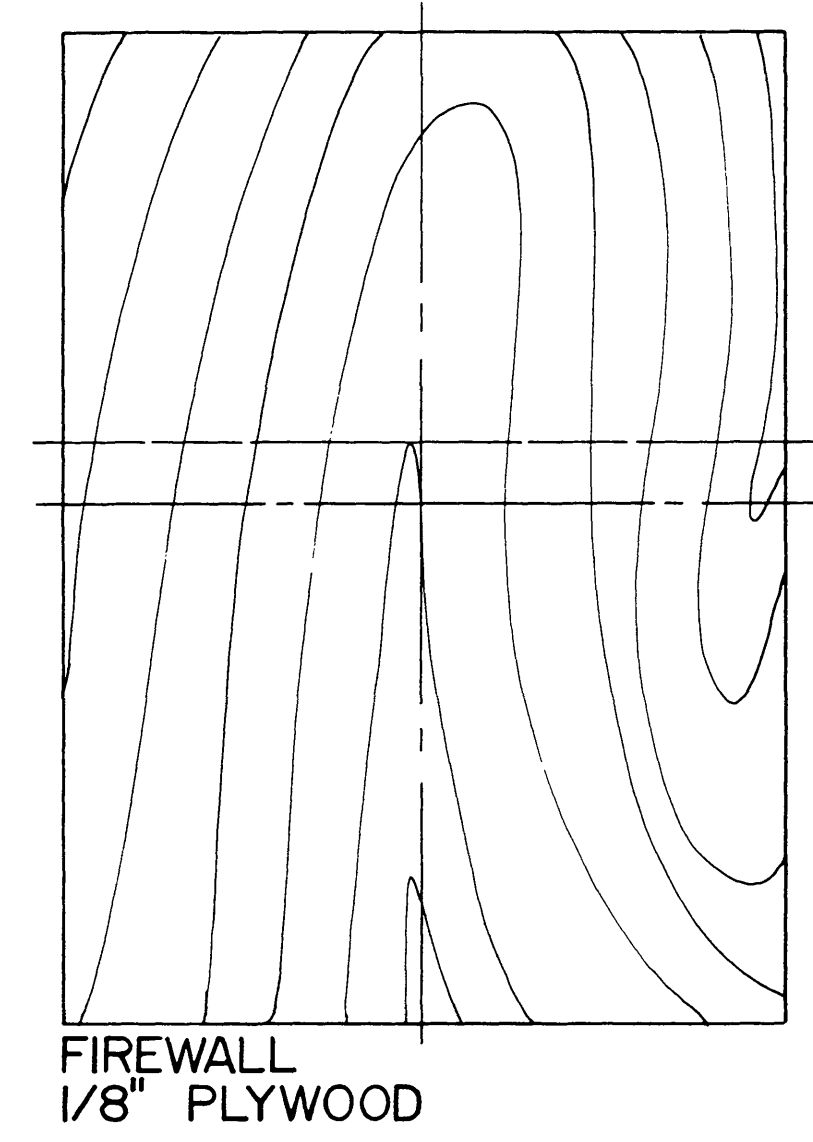
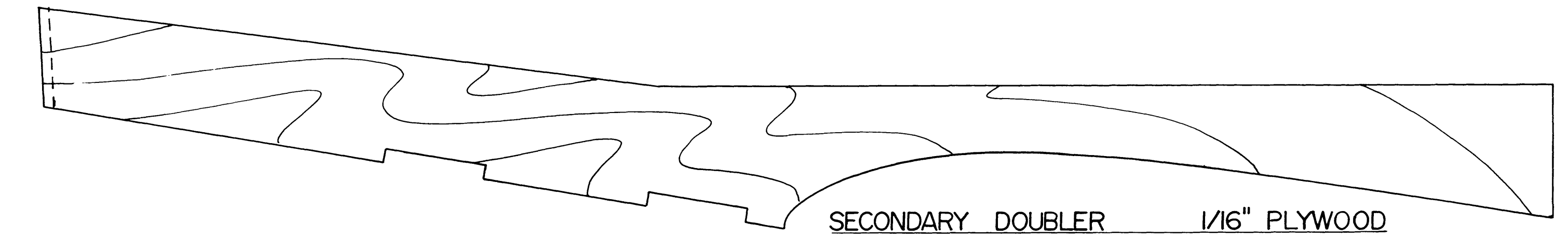
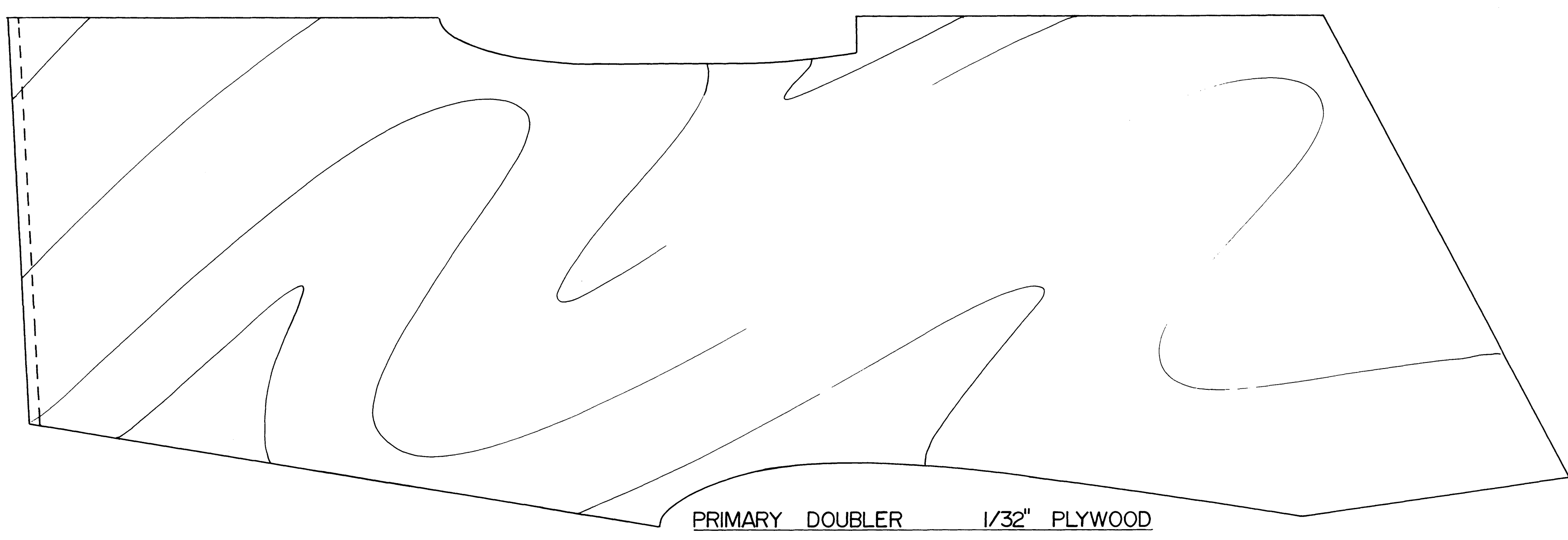
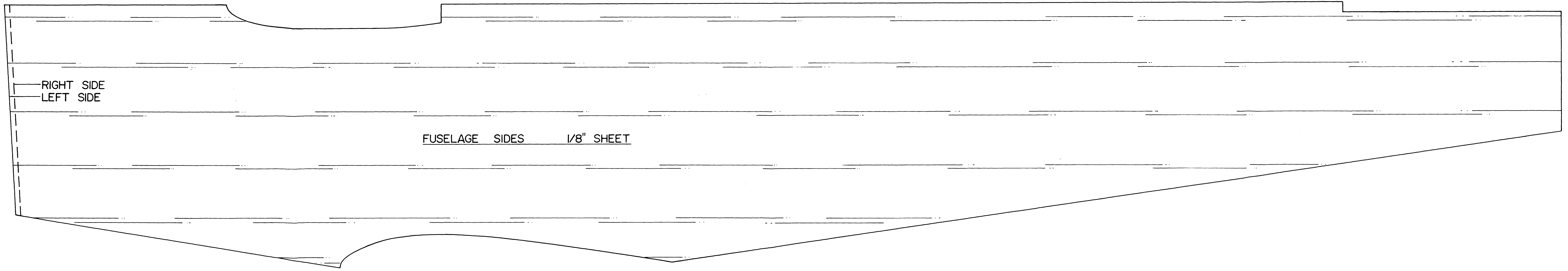

RCM ALL COMMERCIAL RIGHTS RESERVED

**TRIPLE-BIPE**

AN INTERCHANGEABLE BIPLANE / TRIPLANE DESIGN

DESIGNED BY: HOWARD "Spinner" SCHUTT  
PLANS BY: DAVID VAUGHN

