

CONTROL SURFACE TRAVEL LIMITS
 AILERONS - 1/4" UP & DOWN
 ELEVATOR - 1/2" UP & DOWN
 RUDDER - 1" LEFT & RIGHT

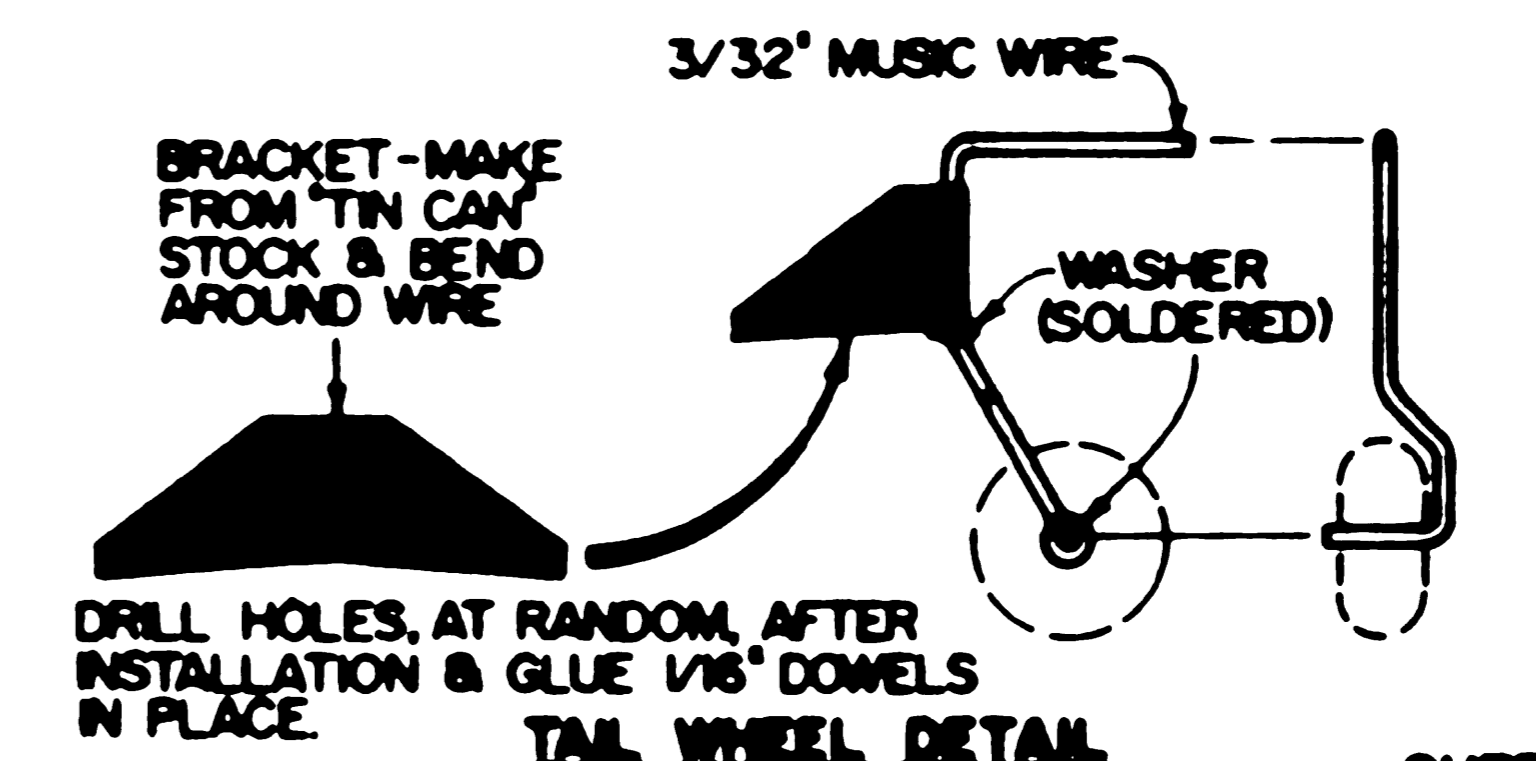
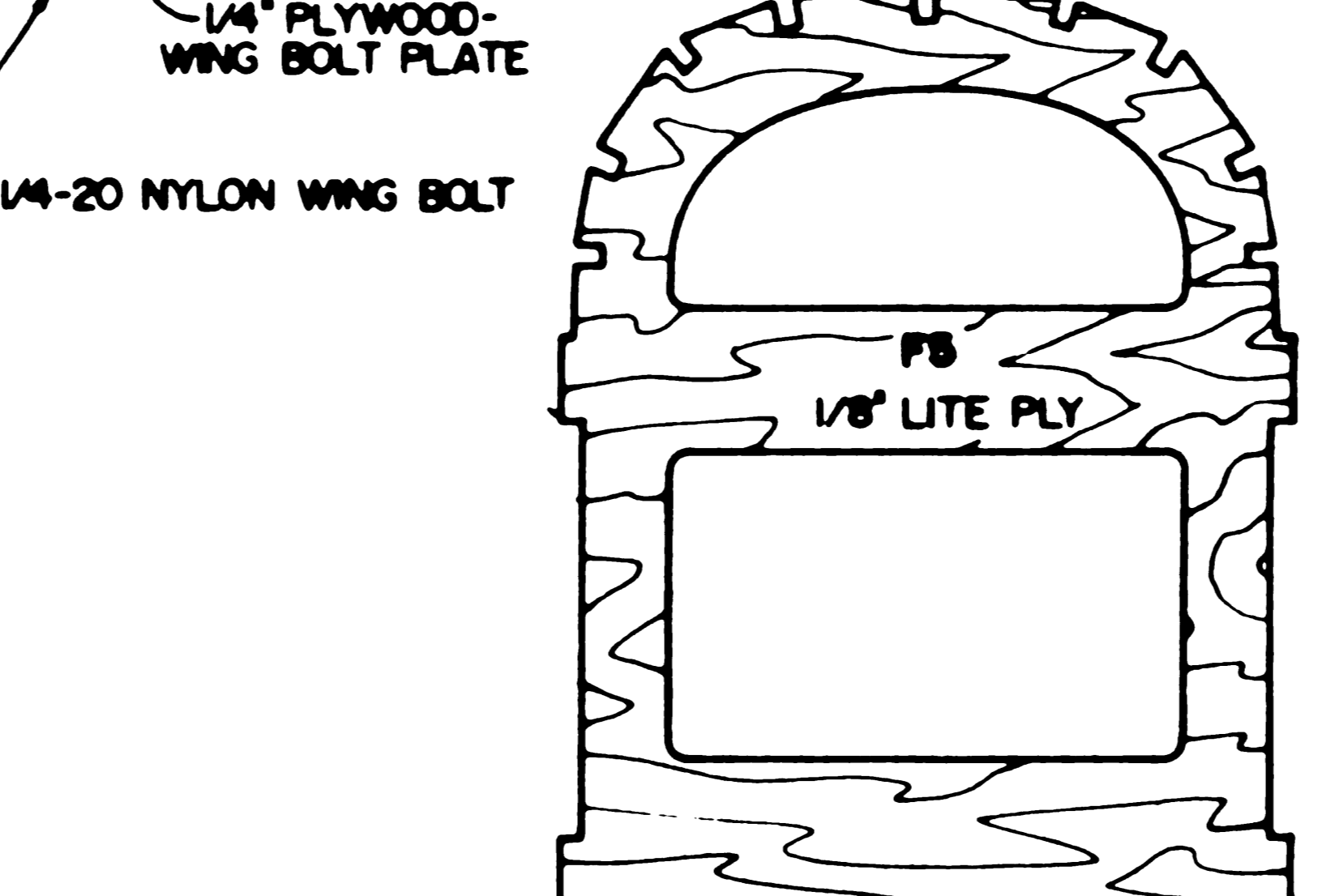
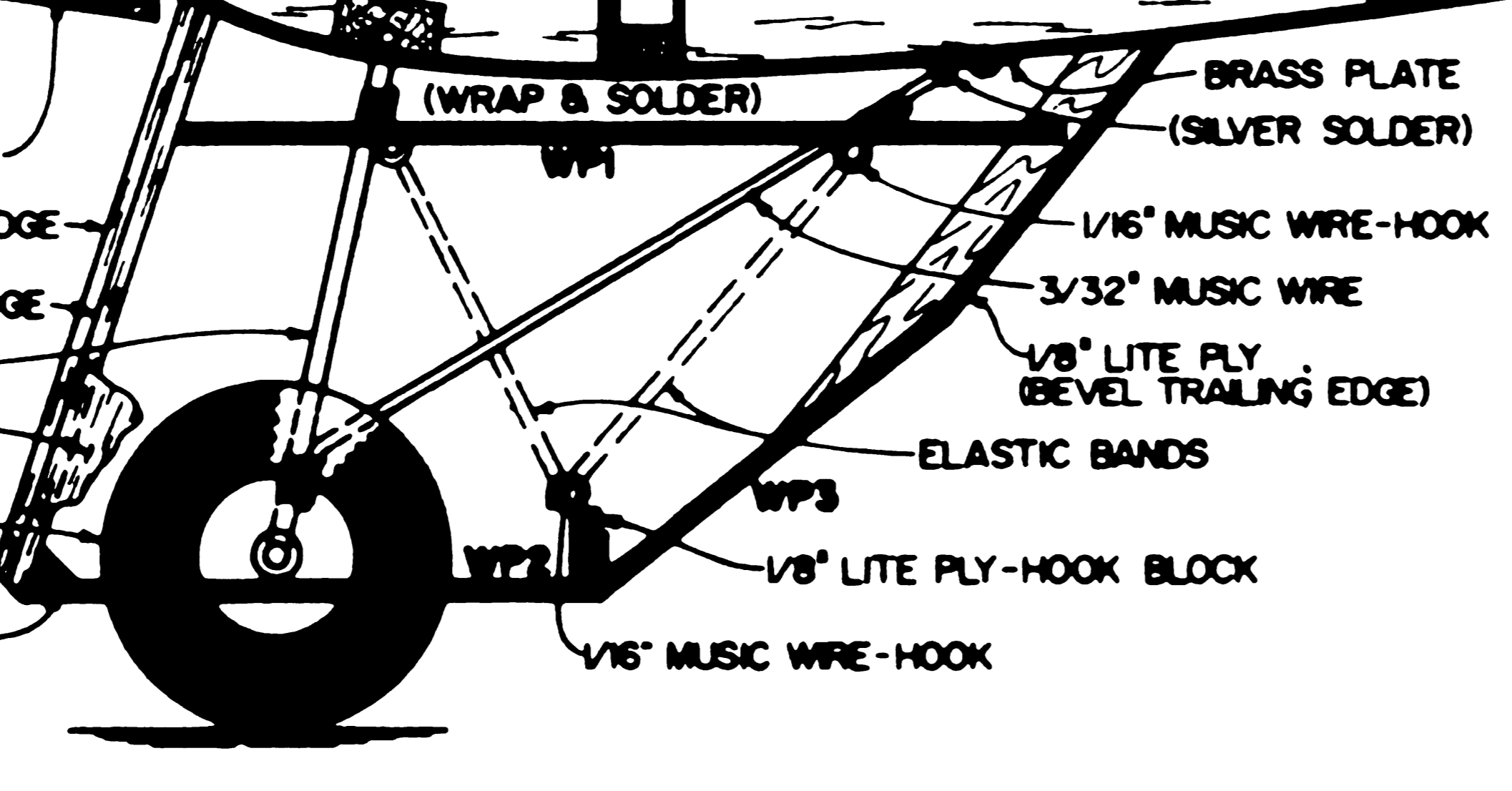
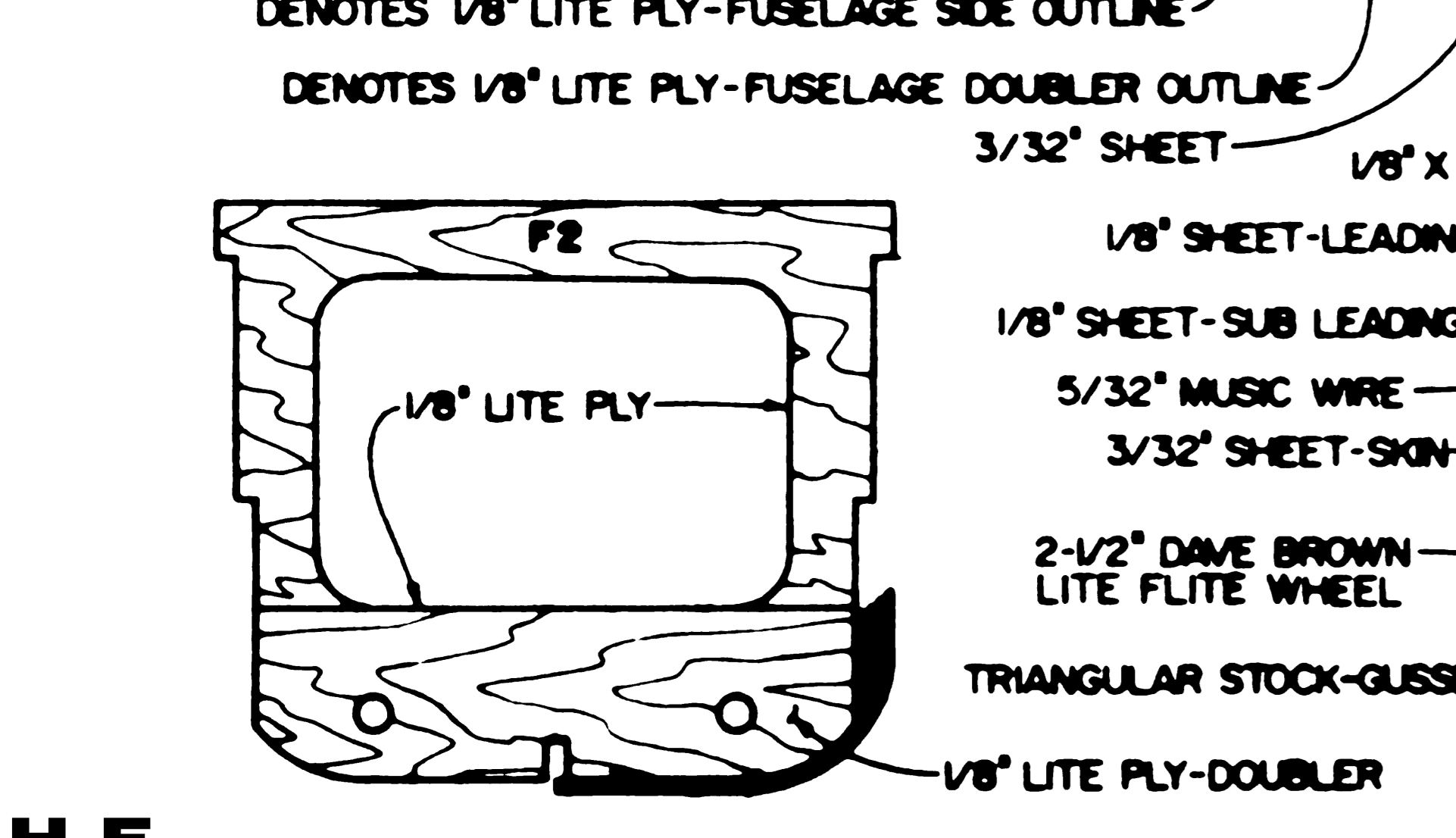
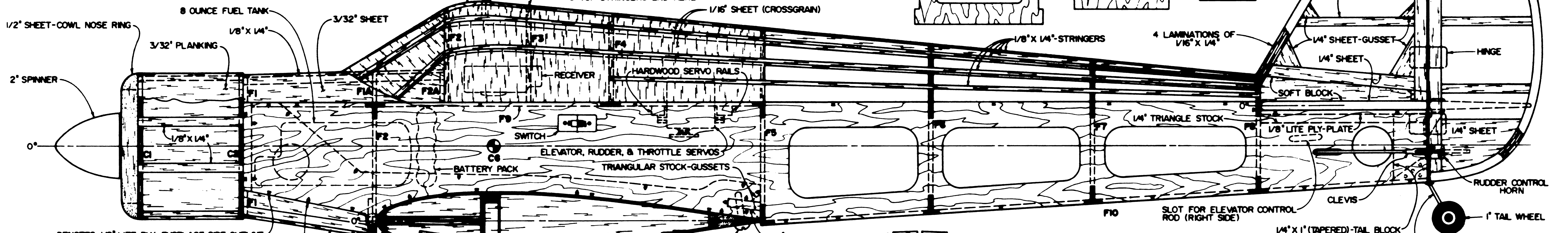
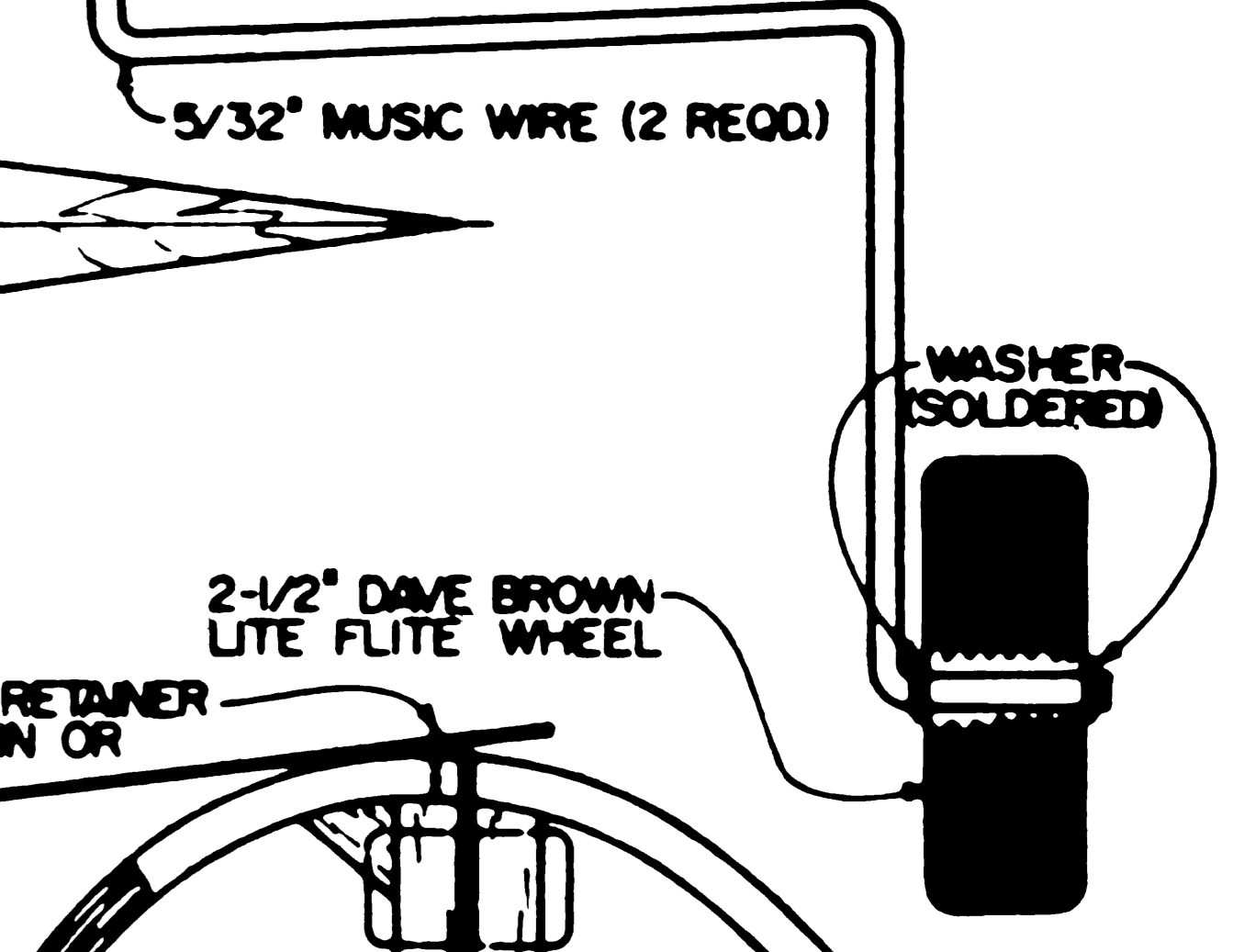
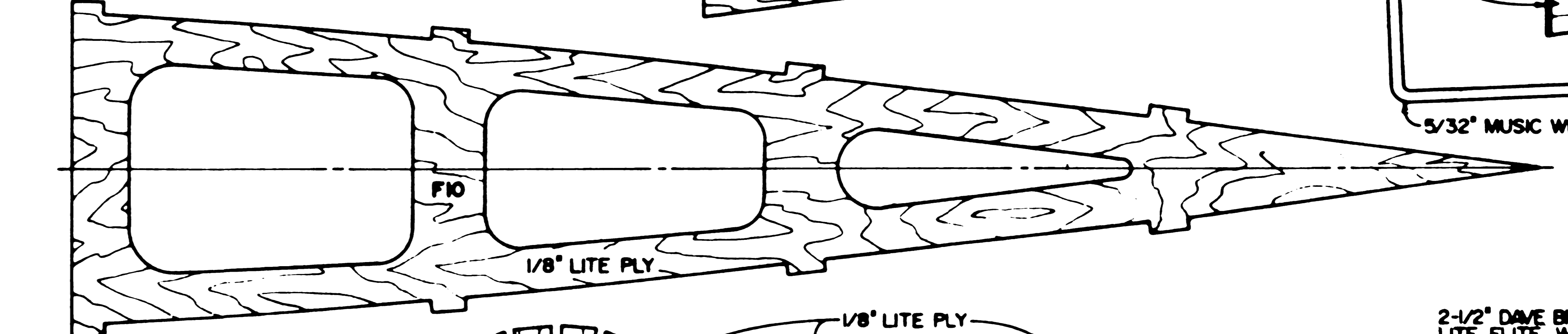
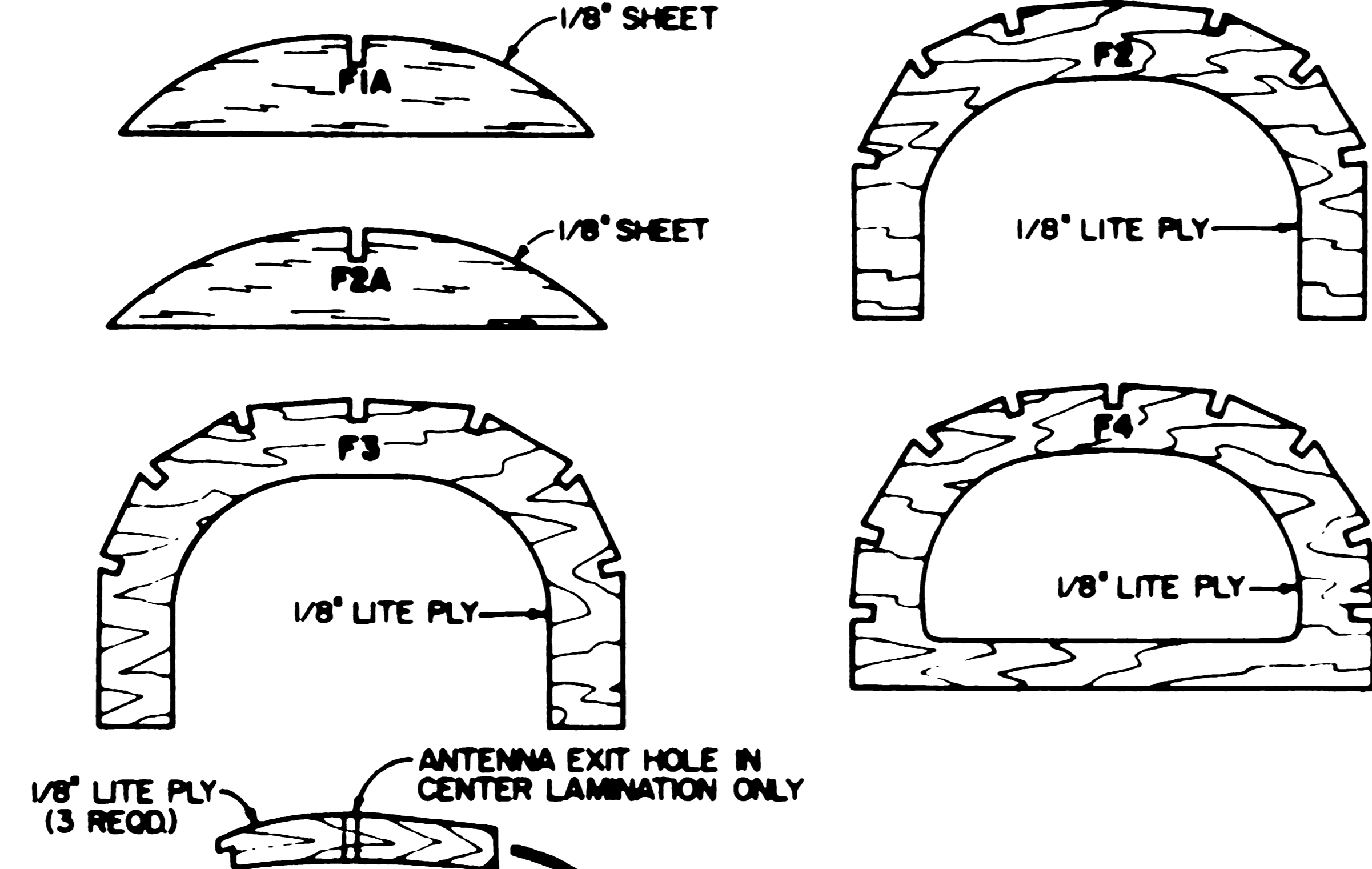
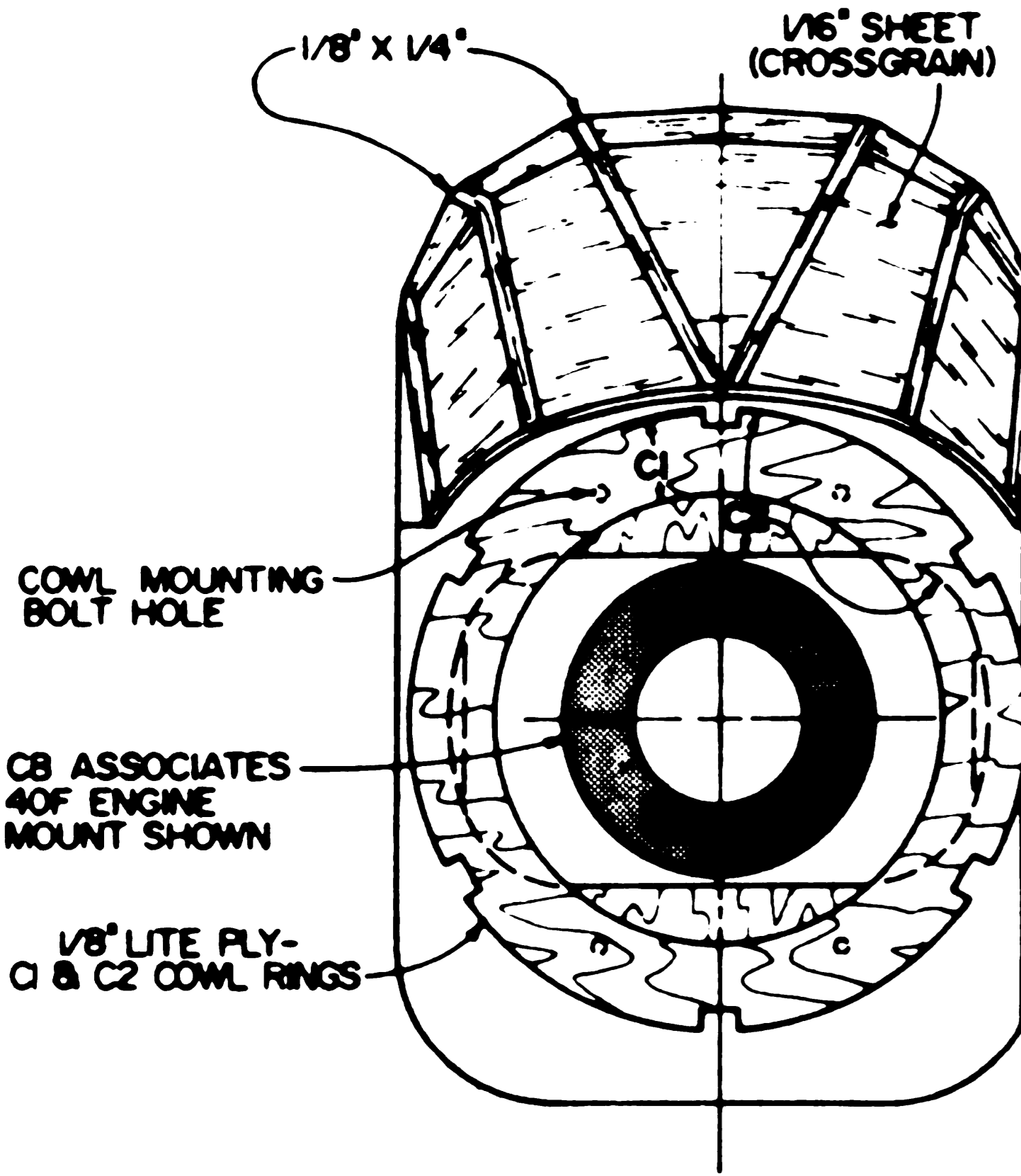
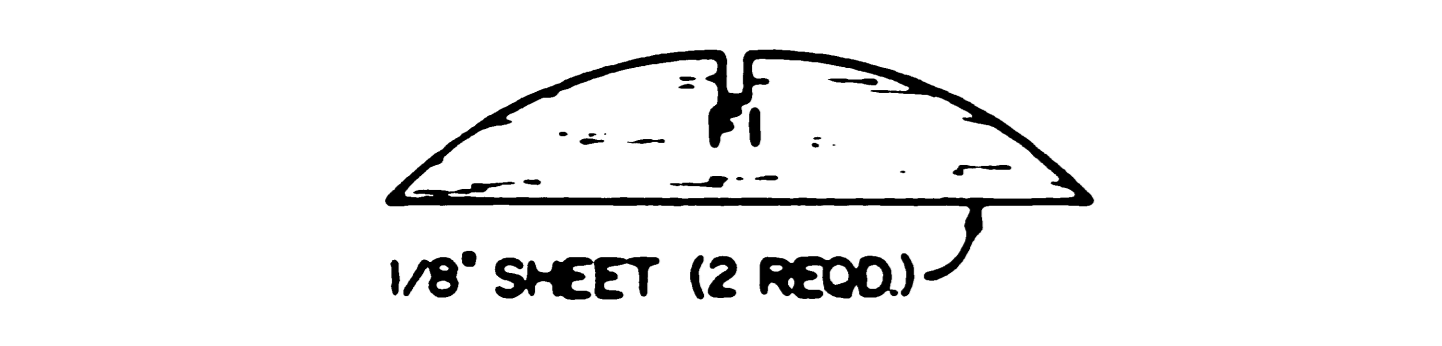
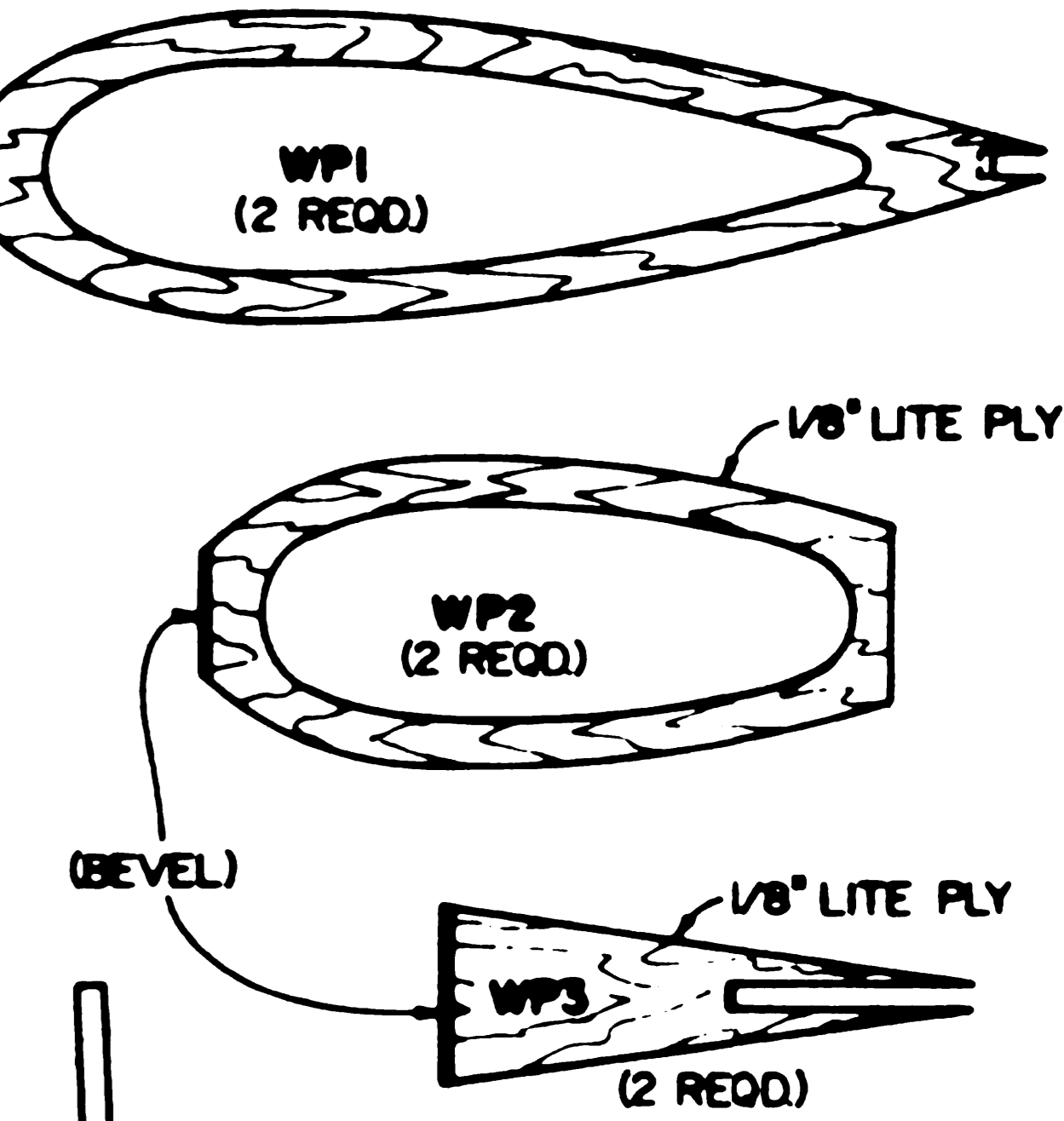
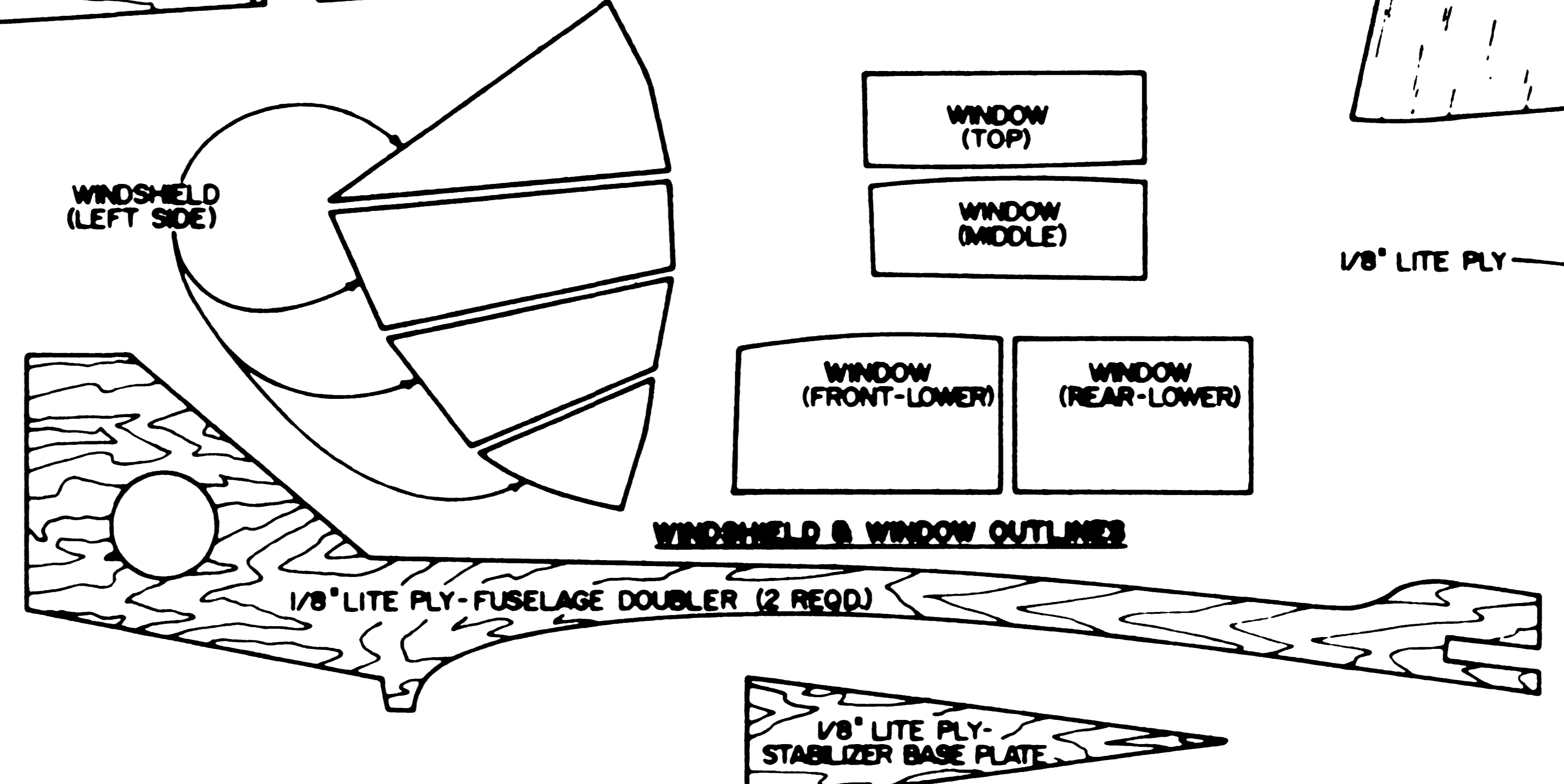
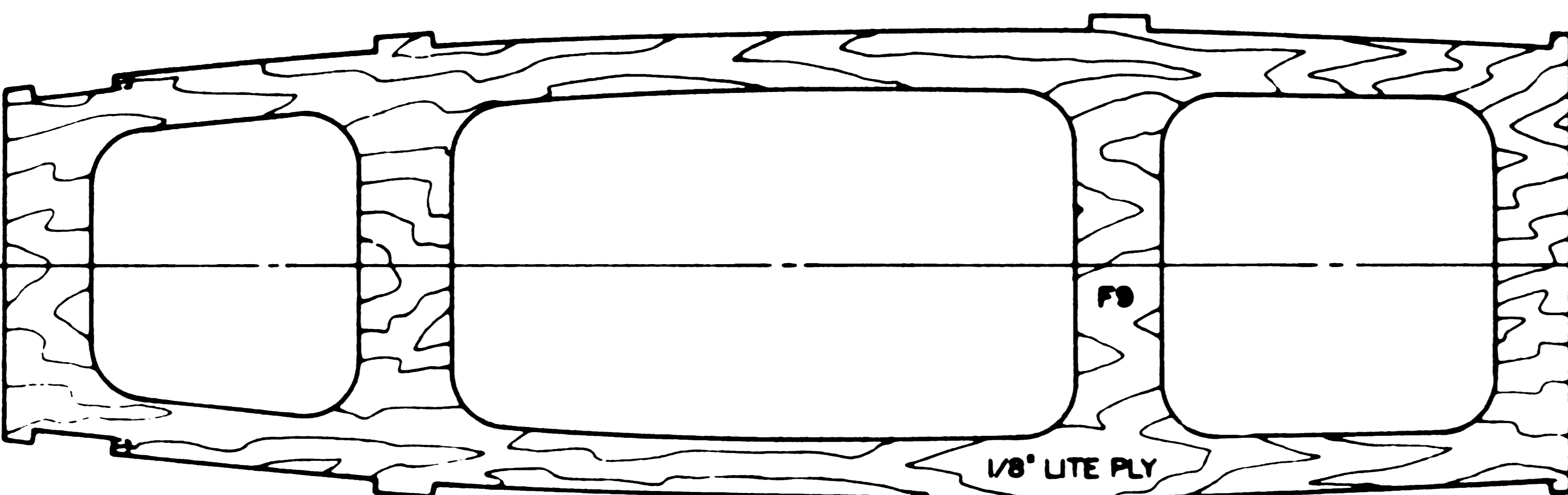

NOTE: ALL WOOD IS BALSA, UNLESS NOTED OTHERWISE.

© 1984 ALL RIGHTS RESERVED

AERONCA ACRO

A 40 POWERED VINTAGE LOOK SPORT DESIGN

DESIGNED BY: ROBERT G. TAYLOR

PLANS BY: Bob Wallace

SHEET 1 OF 2

PLAN #1288

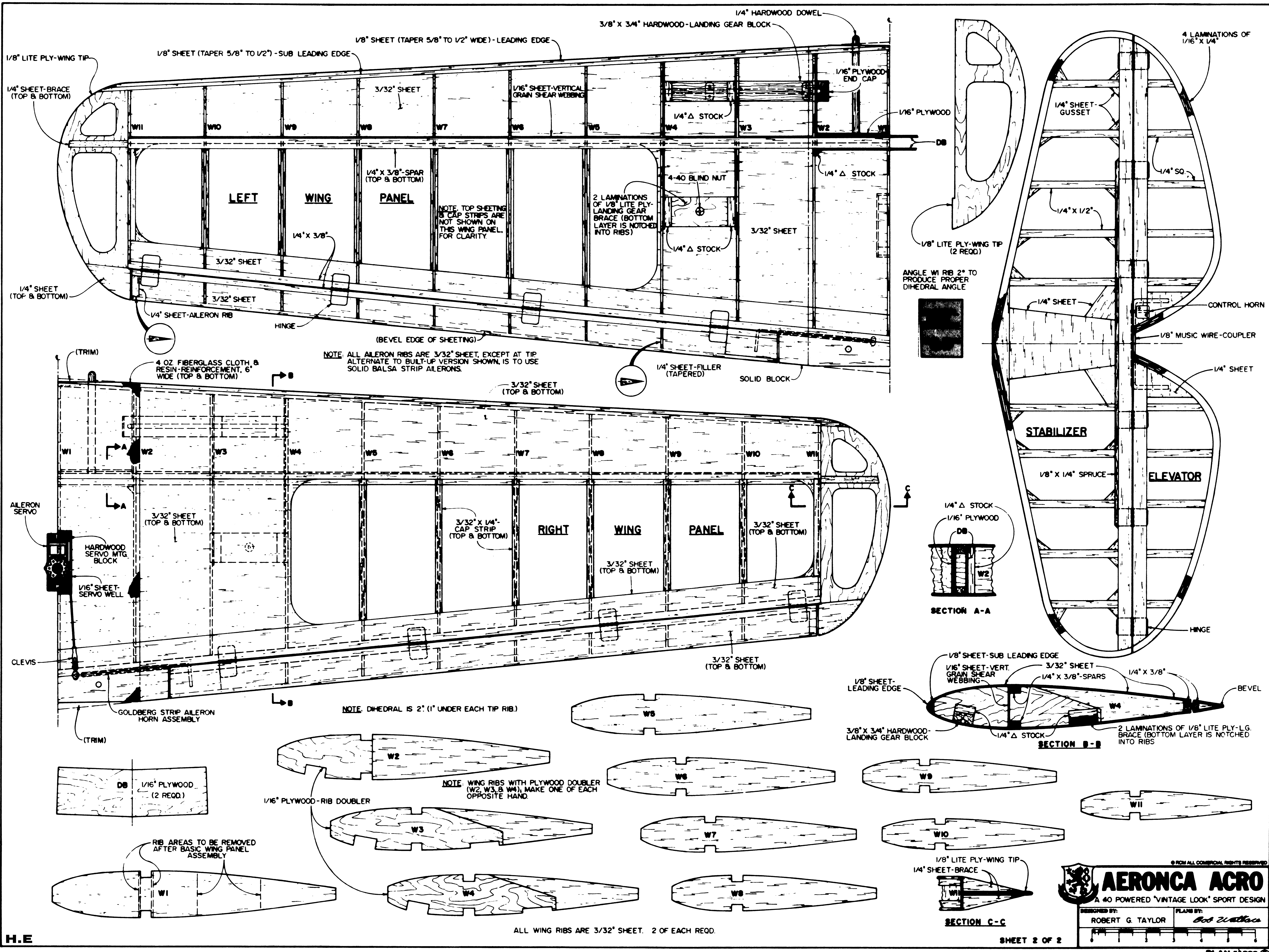

1/8" LITE PLY-WING TIP

1/4" SHEET-BRACE (TOP & BOTTOM)

1/4" SHEET (TOP & BOTTOM)

ALERON SERVO

CLEVIS

(TRIM)

H.E

1/8" SHEET (TAPER 5/8" TO 1/2") - SUB LEADING EDGE

LEFT WING PANEL

3/32" SHEET (TOP & BOTTOM)

1/16" PLYWOOD (2 REQD.)

RIB AREAS TO BE REMOVED AFTER BASIC WING PANEL ASSEMBLY

NOTE: ALL AILERON RIBS ARE 3/32" SHEET, EXCEPT AT TIP. ALTERNATE TO BUILT-UP VERSION SHOWN, IS TO USE SOLID Balsa STRIP AILERONS.

NOTE: DIHEDRAL IS 2° (1" UNDER EACH TIP RIB.)

NOTE: WING RIBS WITH PLYWOOD DOUBLER (W2, W3, & W4), MAKE ONE OF EACH OPPOSITE HAND.

ALL WING RIBS ARE 3/32" SHEET. 2 OF EACH REQD.

3/8" X 3/4" HARDWOOD-LANDING GEAR BLOCK

1/4" Δ STOCK

4-40 BLIND NUT

1/4" Δ STOCK

1/4" SHEET-FILLER (TAPERED)

W2

W3

W4

W5

W6

1/4" HARDWOOD DOWEL

1/16" PLYWOOD END CAP

1/4" Δ STOCK

1/4" Δ STOCK

SOLID BLOCK

3/32" SHEET (TOP & BOTTOM)

W5

W6

W7

W8

W9

1/16" PLYWOOD

1/4" Δ STOCK

1/4" Δ STOCK

1/4" Δ STOCK

1/4" Δ STOCK

1/4" Δ STOCK

3/8" X 3/4" HARDWOOD-LANDING GEAR BLOCK

1/4" Δ STOCK

1/16" PLYWOOD

1/8" LITE PLY-WING TIP

1/4" SHEET-BRACE

SECTION C-C

ANGLE W1 RIB 2° TO PRODUCE PROPER DIHEDRAL ANGLE

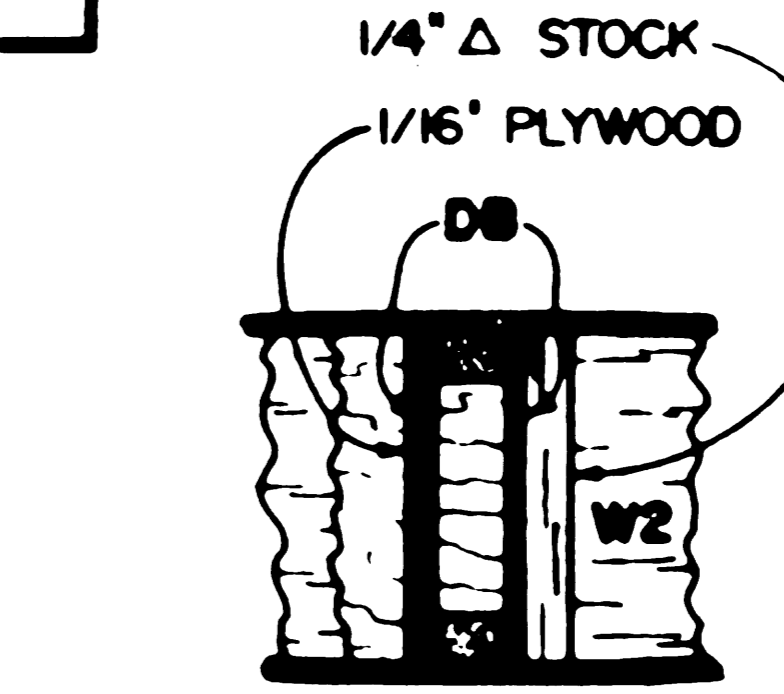
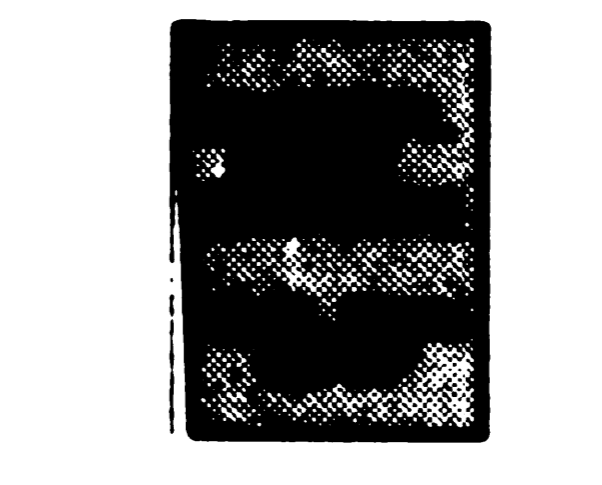

SECTION A-A

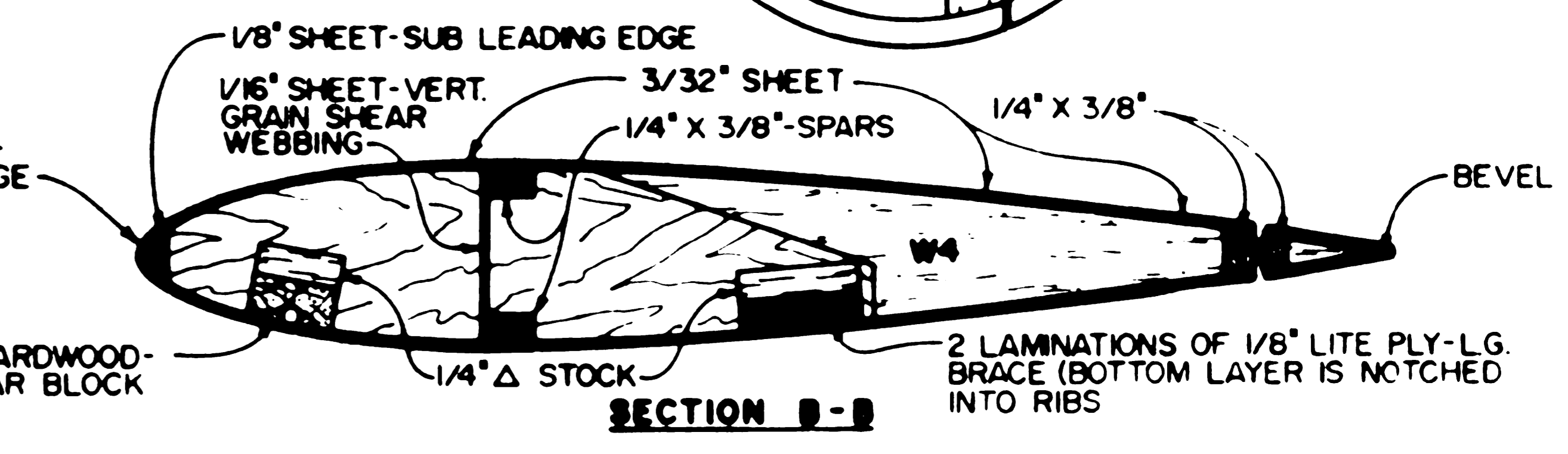

SECTION B-B

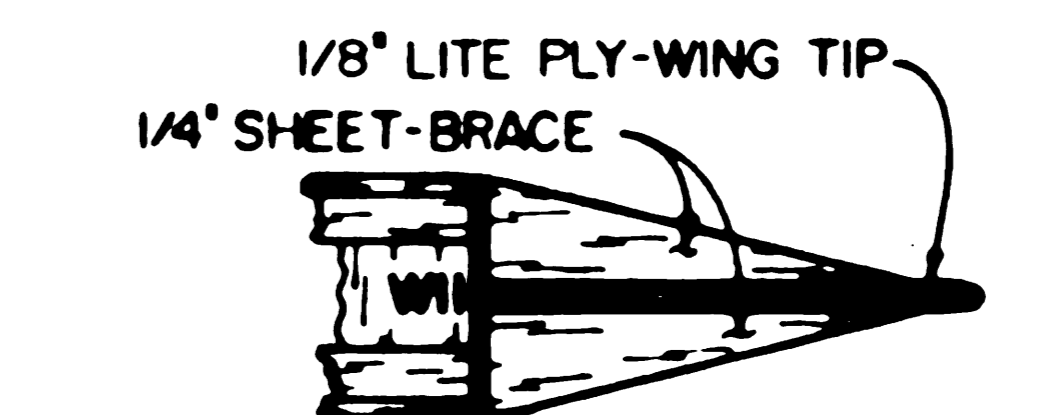

SECTION C-C

SHEET 2 OF 2

4 LAMINATIONS OF 1/16" X 1/4"

1/4" SHEET-GUSSET

1/4" X 1/2"

1/4" SHEET

STABILIZER

1/8" X 1/4" SPRUCE

HINGE

1/8" SHEET-SUB LEADING EDGE

1/16" SHEET-VERT. GRAIN SHEAR WEBBING

3/32" SHEET

1/4" X 3/8"-SPARS

1/4" X 3/8"

2 LAMINATIONS OF 1/8" LITE PLY-L.G. BRACE (BOTTOM LAYER IS NOTCHED INTO RIBS)

AERONCA ACRO
A 40 POWERED 'VINTAGE LOOK' SPORT DESIGN

DESIGNED BY: ROBERT G. TAYLOR
PLANS BY: Bob Wallace

PLAN #1208