



James Cahill

### ABOUT JAMES CAHILL

**J**IM'S first flying model was a high-climb Baby R. O. G. He built it in 1929, from plans and kit furnished by the old Airplane Model League of America. The model's flight of 37 seconds proved mighty encouraging to Cahill.

In 1932 he entered the Nationals at Dayton and took home considerable experience, together with an honorable-mention certificate. The next two national meets were too far from his home in Indianapolis for him to enter.

When Akron was announced as the location of the 1934, Cahill was all prepared and ready for the contest. And at this contest he won his first national trophy—Stout outdoor fuselage trophy. From that time up to the present, modelers have tried in vain to dislodge Cahill from the top of the modeling ladder.

We were tickled to learn that he had won the Moffett this summer at Detroit. The "Hoosier Hick," as we jokingly call him, came through in fine fashion, flying the most outstanding of all the famous Cahill-designed models.

Cahill builds all kinds of models. His pet peeve is that too much emphasis is being placed on gas models at the expense of other types of models.

Knowing the Hoosier Hick is one of the best treats the model hobby has ever given us.

# 1937 MOFFETT TROPHY WINNER

*Detailed plans for duplicating the model sensation of the Nationals.*

By James Cahill

*in collaboration with Gordon S. Light*

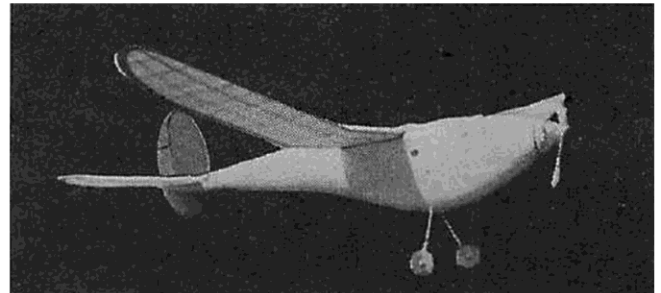

The trophy-winning model is an example of the influence of the new weight rules.

**T**HIS model was designed especially for the Wakefield and Moffett International contest. It is known as Clodhopper II. Clodhopper I was Cahill's entry in the 1936 Wakefield contest. Like most famous models

it was still in the last stages of construction the night before the contest. Despite the fact that it lacked some necessary sandpapering and doping, it flew perfectly and required few adjustments.

On the first flight, under full power, it showed a slight stall—both under power and in the glide—turning in only 1:02. Jimmy went to work and applied the necessary adjustments. On the next flight it hit a weak thermal about 400 feet above the hangar of Detroit's Wayne County Airport. Leisurely, it flew in circles above the hangar, taking advantage of the rising air to turn in a flight of 13:32. On the third flight it flew nicely for 2:20. But this flight was turned in at five thirty and the air was calm and free from thermals.

These three flights gave Cahill an average of 5:33 and won him a place on both the Wakefield and Moffett elimination teams.

During the finals of the Moffett the Clodhopper II really showed its true form. On its first official flight it climbed up fast, gained plenty of altitude before the propeller folded back and the model went into its glide. It was soon evident that a strong thermal had the model

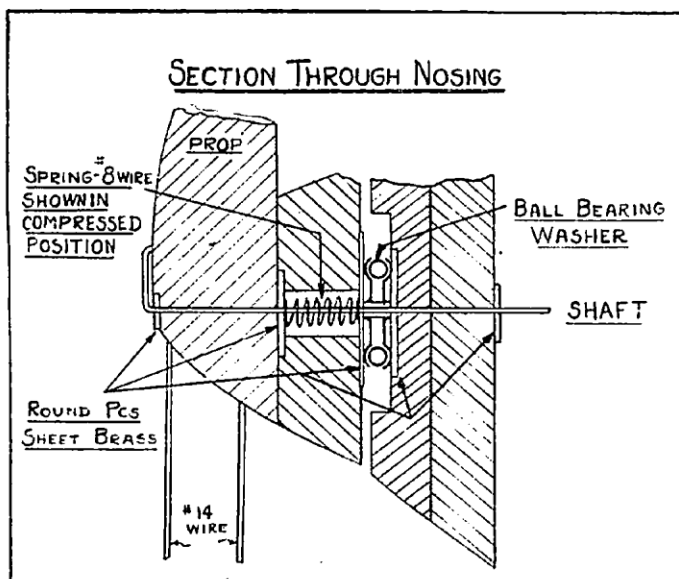

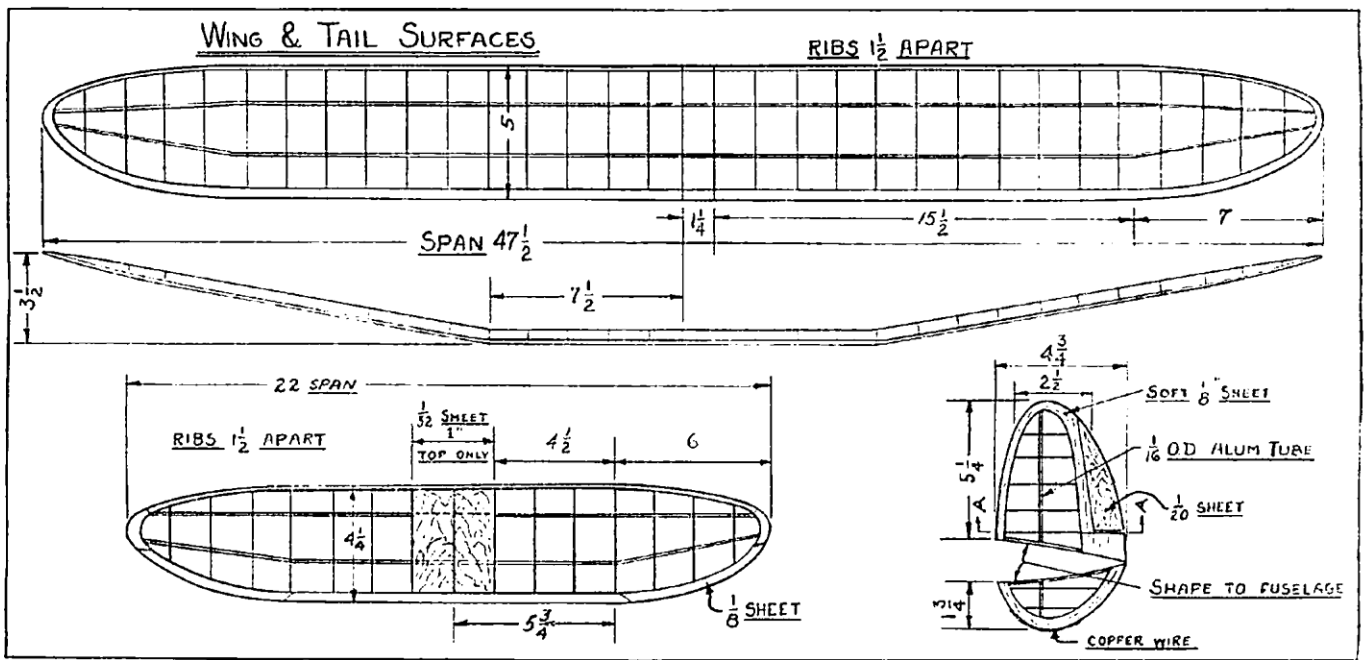

well in hand. It was sucked toward a white cumulus cloud and soon became a speck in the sky. It hopped from the first cloud to another one. And, despite a merry five-mile chase in an automobile, it was lost far off on the horizon. And that was the last Cahill has seen of his model. Luckily, Bruno Marchi, of Boston, took photos of the model shortly before it was lost. He allowed us to use them to illustrate this article on Clodhopper II.

Cahill regrets that he was unable to take this model to England for the Wakefield finals. He feels sure that it

would have made a good showing in any contest. After examining the details of the design, you'll agree that it's one of the most outstanding models ever built.

### FUSELAGE

All bulkheads are made of light-grade  $\frac{1}{32}$ " sheet balsa cemented cross grain. 4 light stringers of  $\frac{1}{8} \times \frac{1}{16} \times 36$ " are used to assemble the bulkheads and hold them in position for planking. The planking is put on in strips of  $\frac{1}{8} \times \frac{3}{8} \times 36$ ". These planks are cut to a narrower width wherever it is necessary to get around the sharp corners of the bulkheads. All landing gear and nose reinforcements ( $\frac{3}{16}$ " sq. at the landing gear and  $\frac{1}{8} \times \frac{3}{16}$ " at the nose) are added before the planking is started.

The tops of former #6 to 10 inclusive are cut off to provide a flat surface for mounting the wing. The wing fits onto this flat section of the fuselage. It is covered by an aluminum sheet cover, which fits over the wing and is bent around formers #5 and 10. This cover is attached by strips of interior decorators' masking tape.

After planking, the fuselage is sanded smooth and is given a coat of wood filler. Follow with U. S. army #4 yellow dope with sandings of finest sandpaper, before and after each coat.

### PROPELLER AND NOSING

The one-blade folding propeller is the most novel feature of the design. The propeller is cut from a block  $1\frac{3}{4} \times 2\frac{1}{4} \times 10$ ". The one blade is cut in the conventional way. After shaping the blade it is covered with silk and a coat of wood filler is added. After the propeller has been mounted to the hub and all necessary cementing has been done, the propeller is given a coat of red dope, with intermittent sanding. And, as a last step, apply a coating of wax and rub the surface to a high luster.

The propeller blade is hinged to the hub with dural hinges and #11-music-wire hinge pin. The propeller blade should be cut away to permit the hinge to fit flat against the propeller surface. The edges of the dural hinges are burred with a file to provide a better cementing surface.

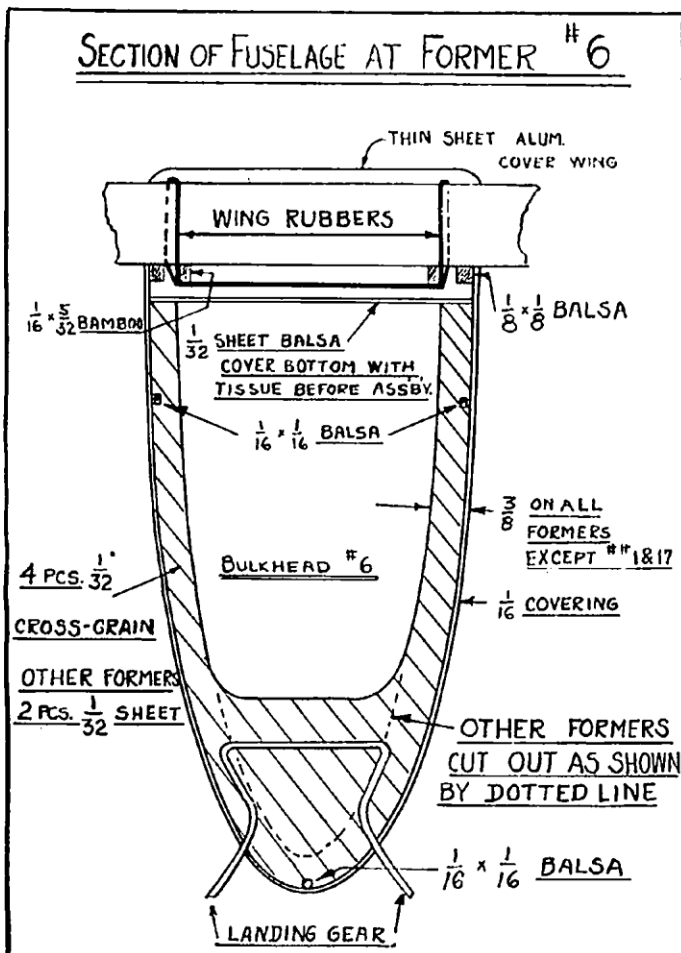

The balance weight for the propeller is a piece of sheet brass rolled cylindrically and filled with solder. It is mounted to the propeller hub by a loop of #14 music wire. It should be of sufficient weight to balance the balsa propeller blade.

The propeller spinner has a piece of wire on it which engages a piece of music wire (attached to the nose plug) at the proper time. This "catch" has three purposes: stop the propeller from free-wheeling; stop it at the same position each time, to get least resistance from the folding blade; prevent slack in the rubber from moving back and forth in the fuselage and disturbing the balance of the model. And, in addition, this tension which remains in the rubber eliminates the use of hooks in the nose and tail plugs, as the rubber exerts sufficient tension to keep them in position.

The propeller "stopper" operates in the following way: When the tension of the rubber is strong, the hook on the spinner rides free. When the motor unwinds, the small wire spring inside the spinner forces the spinner forward and the hook on the spinner engages the loop of wire attached to the nose plug.

Cahill predicts that the folding and feathering propeller will prove far superior to the present free-wheeler which is popular among contest modelers. Incidentally, Cahill is the first modeler to use the featherer and folder on a model.

### WING

Ribs are cut, using the template in the drawing. All the ribs are mounted on the 2 center spars before any of them are cemented in place. The spars are built up from pieces of  $\frac{1}{16}$ " and  $\frac{3}{16}$ " flat balsa. The size is indicated in the rib pattern. The spars taper toward the tip of the wing. At the tip, the rear spar changes from a hollow built-up to a solid spar.

The center of the wing is flat for a length of 15 inches. The outline of the wing tip is built up from  $\frac{1}{8}$ " sheet balsa. Where the thickness required is greater than  $\frac{1}{8}$ ", laminate 2 thicknesses of sheet balsa. A strip of silk is doped to the outline of each wing tip to strengthen the balsa tip.

The wing is covered with bamboo paper, water-doped and treated with two coats of Fokker Red dope. It is sanded with fine sandpaper (rubbing chordwise) after each coat of dope.

(Turn to page 96)

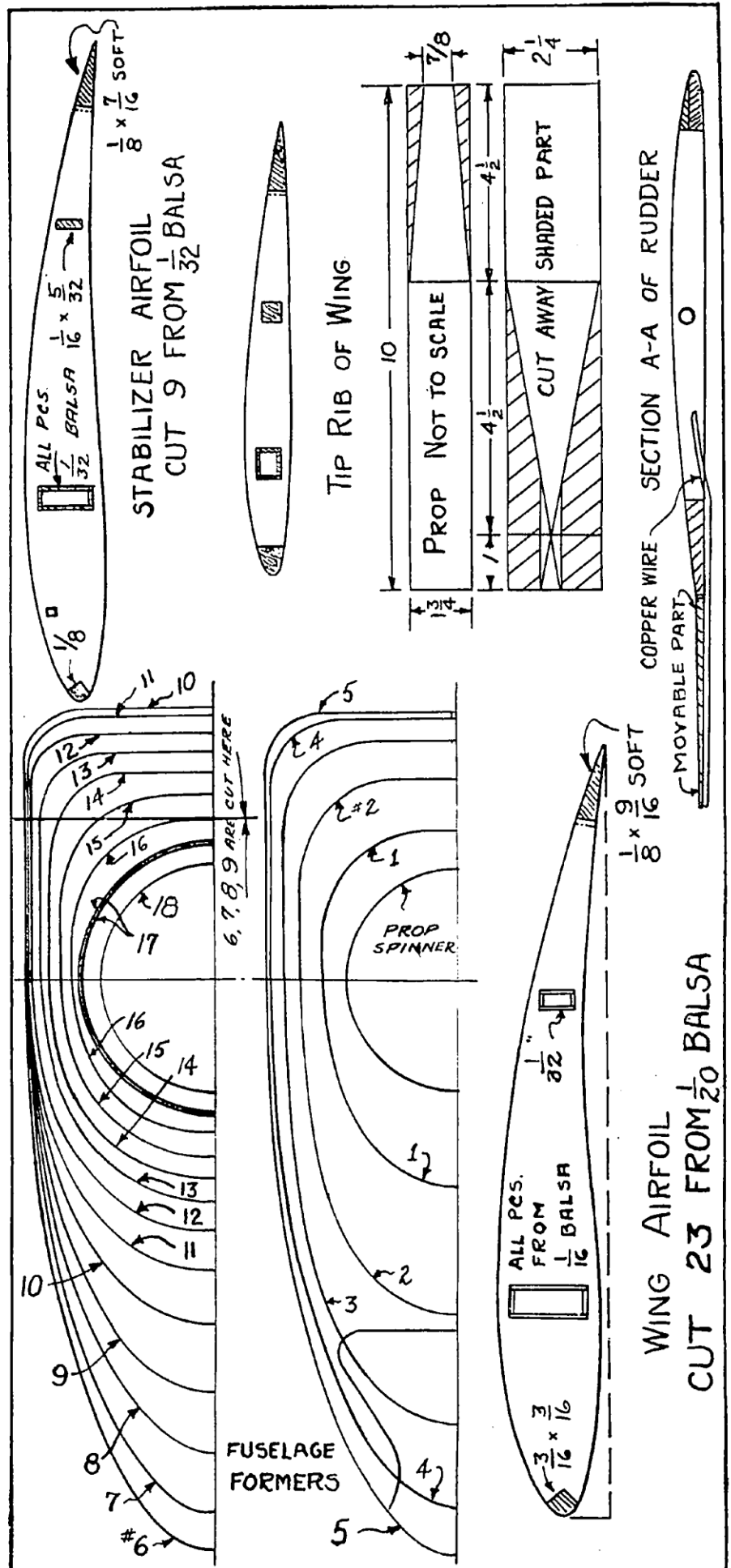

# 1937 MOFFETT TROPHY WINNER

(Continued from page 43)

**TAIL** from  $\frac{1}{32}$ " sheet balsa. The rear spar is solid— $\frac{1}{16} \times \frac{1}{32}$ ". The tips of the elevator the wing. The front spar is built up are built the same as the wing tips.

A typical section of the rudder—marked AA—is shown in the drawing. The rear portion of the rudder is  $\frac{1}{16}$ " sheet balsa secured to the main rudder with two short pieces of soft copper wire. The main spar of the rudder is  $\frac{1}{16}$ " outside diameter aluminum tubing. This spar runs through the fuselage from the top portion of the rudder to the bottom part.

Both rudder and elevator are covered with ordinary outdoor variety tissue. Follow with water doping and one coat of dope. Use glider polish on the flexible portion of the rudder. The elevator and rudder are both mounted rigidly to the rear end of the fuselage. Balsa fillets are cemented between the rudder and elevator at the point where they join the fuselage. The elevator is set at zero degrees incidence. That is, the bottom surface is directly in line with the center line of the fuselage. Check the alignment carefully while assembling.

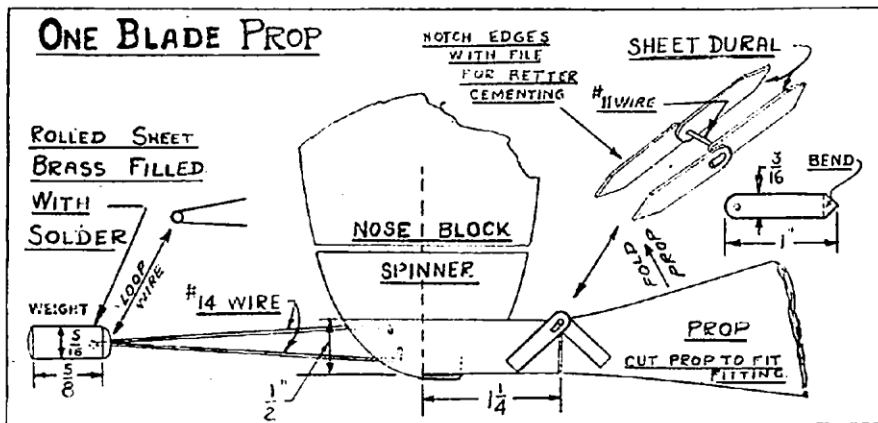

The 1937 winner sported a feathering, one-blade prop.

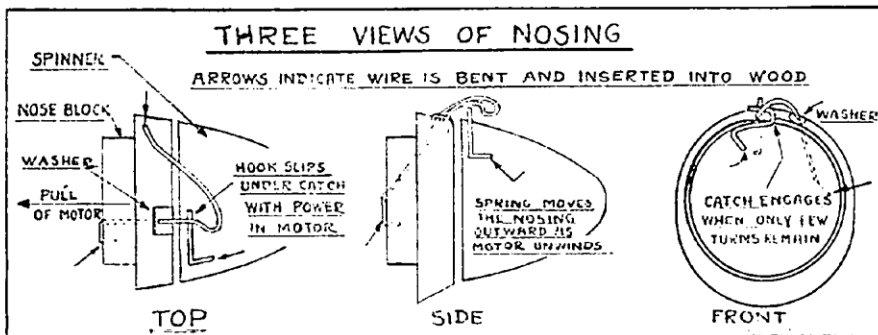

Below: Because of the tensioner, the rear fuselage section stays attached without hooks, etc.

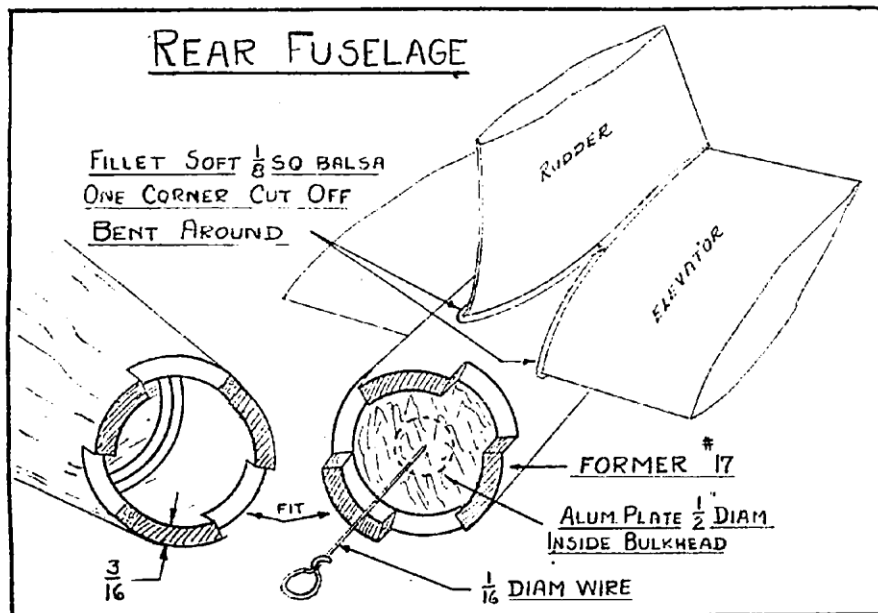

## LANDING GEAR

This landing gear has the least resistance of any type we've yet seen on any model. There is a minimum of exposed parts because of the fuselage shape. This landing gear is partly responsible for the slow sinking speed of the Clodhopper II. Impartial observers credit this model with the slowest sinking speed of any model entered in the 1937 national meet.

Landing-gear supports consist of one piece of  $\frac{1}{16}$ " diameter wire bent to shape and secured to former #6. The wheels are  $\frac{1}{16}$ " thick cut from three-ply balsa veneer. Aluminum tubes are inserted through the wheels to provide smooth running. Conical pieces of pine wood are cemented to both sides of the wheel to support this aluminum tubing. Pronged aluminum discs may be substituted.

## MOTOR

16 strands of  $\frac{1}{4} \times \frac{1}{30}$ " brown rubber were used. It is lubricated with prepared rubber lubricant. The motor was 19 inches long. Rubber tubing was used on all wire fittings which contacted the rubber. This is important. The rubber strands will be cut by an unprotected wire fitting.

## COLORING

U. S. army #4 yellow was used on the fuselage and elevator. Fokker Red was used on the wing, rudder, propeller and wheels. Complete and ready to fly, the model weighed 8.4 ounces.